

## Proportional throttle cartridge with integrated electronics

- ◆ direct operated
- ◆  $Q_{\max} = 65 \text{ l/min}$
- ◆  $Q_{N\max} = 63 \text{ l/min}$
- ◆  $p_{\max} = 350 \text{ bar}$

### DESCRIPTION

Direct operated proportional throttle valve with integrated electronics as screw-in cartridge for cavity according to ISO 7789. With the solenoid deenergised, the control spool is held in the closed position by a spring. The change of the electric current is followed by a proportional volume flow change. Progressive increase and decrease of volume flow and reduced hysteresis are characteristics of this valve. The Plug & Play valves are factory set and adjusted and have therefore a high valve-to-valve reproducibility. The control takes place via an analogue interface or a fieldbus interface (CANopen, J1939 or Profibus DP). The parameterisation takes place by means of the free of cost parameterisation and diagnostics software «PASO» or via fieldbus interface. The USB parameterisation interface is accessible through a screw plug. As an option, these valves are available with integrated controller. As feedback value generators sensors with voltage or current output can be connected directly. The available controller structures are optimised for applications with hydraulic actuations.

### SYMBOL

„normally closed“ DN

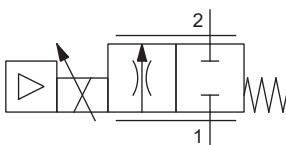

### MANUAL OVERRIDE

HB4,5 as standard

M33 x 2  
ISO 7789

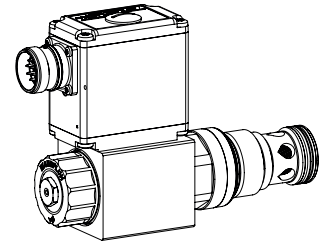
### APPLICATION

Proportional throttle valves with integrated electronics are perfectly suitable for demanding applications in which the volume flow frequently has to be changed. They are used in applications where high valve-to-valve reproducibility, easy installation, comfortable operation and high precision are very important. The integrated controller relieves the machine control and operates the volume flow control in a closed loop circuit. The applications are in the industrial as well as in the mobile hydraulics for the smooth control of hydraulic actuations. The screw-in cartridge is perfectly suitable for installation in control blocks and is installed in sandwich- (vertical stacked systems) and in flange plates (corresponding data sheets in this register). For machining the cartridge cavity in steel and aluminum blocks, cavity tools are available (hire or purchase). Please refer to the data sheets in register 2.13.

#### Note!



„PASO“ is a Windows programm in the flow diagram style, which enables the intuitive adjustment and storing of all variable parameters. The data remain saved in case of a power failure and can also be reproduced and transferred to other DSV.

### ACTUATION

Actuation	Proportional solenoid, wet pin push type, pressure tight
Connection	Via device receptacle

### ELECTRICAL SPECIFICATIONS

Protection class	IP67 with suitable mating connector and closed housing cover
Ramps	Adjustable
Parameterisation	Via fieldbus or USB
Supply voltage	12 VDC, 24 VDC

#### Note!



Exact electrical specifications and detailed description of «DSV» electronics can be found on data sheet 1.13-76.

**TYPE CODE**

		D N P PM33 - <input type="text"/> - <input type="text"/> / M E <input type="text"/> <input type="text"/> - <input type="text"/> HB4,5 # <input type="text"/>	
Throttle valve			
Normally closed			
Proportional			
Schraubpatrone M33 x 2			
Screw-in cartridge Q <sub>N</sub>	32 l/min	<input type="text" value="32"/>	
	63 l/min	<input type="text" value="63"/>	
Nominal voltage U <sub>N</sub>	12 VDC	<input type="text" value="G12"/>	
	24 VDC	<input type="text" value="G24"/>	
Slip-on coil	Metal housing square		
Connection execution	Integrated electronics		
Hardware configuration			
Analog command value signal	12 pole	<input type="text" value="A1"/>	7 pole <input type="text" value="D1"/> (0...10 V preset)
Analog command value signal	12 pole	<input type="text" value="A4"/>	7 pole <input type="text" value="D4"/> (4...20 mA preset)
CANopen according to DSP-408	<input type="text" value="C1"/>		
Profibus DP according to Fluid Power Technology	<input type="text" value="P1"/>		
CAN J1939 (on request)	<input type="text" value="J1"/>		
Function			
Amplifier	<input type="text"/>		
Controller with current feedback value signal (0...20 mA / 4...20 mA)	<input type="text" value="R1"/>		
Controller with voltage feedback value signal (0...10 V)	<input type="text" value="R2"/>		
Sealing material	NBR	<input type="text"/>	
	FKM (Viton)	<input type="text" value="D1"/>	
Manual override			
Design index (subject to change)			

2.6-561

**GENERAL SPECIFICATIONS**

Designation	Proportional throttle valve with integrated electronics
Construction	Direct operated
Mounting	Screw-in cartridge construction
Nominal size	M33 x 2 according to ISO 7789
Actuation	Proportional solenoid
Ambient temperature	-20...+65 °C The upper temperature limit is a guideline for typical applications, in individual cases it may also be higher or lower. The electronics of the valve limit the power in case of a too high electronics temperature. More detailed information can be obtained from the operating instructions „DSV“.
Weight	1,5 kg
MTTFd	150 years

**HYDRAULIC SPECIFICATIONS**

Working pressure	p <sub>max</sub> = 350 bar
Maximum volume flow	Q <sub>max</sub> = 65 l/min
Volume flow direction	1 → 2
Leakage oil	On request
Nominal volume flow range	Q <sub>N</sub> = 32; 63 l/min
Hysteresis	≤ 8 %
Fluid	Mineral oil, other fluid on request
Viscosity range	12 mm <sup>2</sup> /s...320 mm <sup>2</sup> /s
Temperature range fluid	-25...+70 °C (NBR) -20...+70 °C (FKM)
Contamination efficiency	Class 18 / 16 / 13
Filtration	Required filtration grade β 6...10 ≥ 75, see data sheet 1.0-50

**ELECTRICAL CONNECTION**

X1	Analog interface (Main)
Device receptacle	M23, 12 pole male
	1 = Supply voltage + 2 = Supply voltage 0 VDC 3 = Stabilised output voltage 4 = Command value signal voltage + 5 = Command value signal voltage - 6 = Command value signal current + 7 = Command value signal current - 8 = Reserved for extensions 9 = Reserved for extensions 10 = Enable signal (Digital input) 11 = Error signal (Digital output) 12 = Chassis
Command value signal voltage (PIN 4/5) resp. current (PIN 6/7) are selected with parameterisation and diagnostics software PASO.	

X1	Fieldbus interface (Main)
Device receptacle	M12, 4 pole male
	1 = Supply voltage + 2 = Reserved for extensions 3 = Supply voltage 0 VDC 4 = Chassis

X2	Parameterisation interface
USB, Mini B	Under the screw plug of the housing cover Factory set

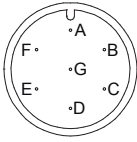
X1	Analog interface (Main)
Device receptacle	Connector DIN EN 175201 - 804
	7 pole male A = Supply voltage + B = Supply voltage 0 VDC C = Not connected D = Command value signal + E = Command value signal - F = Not connected G = Chassis
Command value signal: current (D4) or voltage (D2) to specify when placing the order	

X3	Profibus interface according to IEC 947-5-2
Device receptacle	M12, 5 pole female B-coded
	1 = VP 2 = RxD / TxD - N 3 = DGND 4 = RxD / TxD - P 5 = Shield

X3	CANopen interface according to DRP 303-1
Device receptacle	M12, 5 pole male
	1 = Not connected 2 = Not connected 3 = CAN Gnd 4 = CAN High 5 = CAN Low

X4 (controller only)	Feedback value interface (sensor)
Device receptacle	M12, 5 pole female
	1 = Supply voltage (output) + 2 = Feedback value signal + 3 = Supply voltage 0 VDC 4 = Not connected 5 = Stabilised output voltage
Feedback value signal: current (R1) or voltage (R2) to specify when placing the order	

**Note!** The mating connector is not included in the delivery

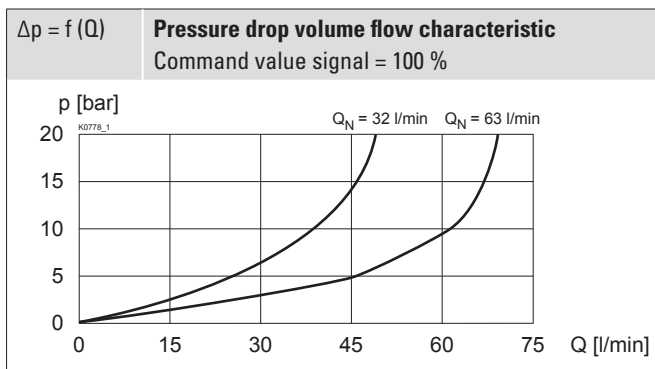
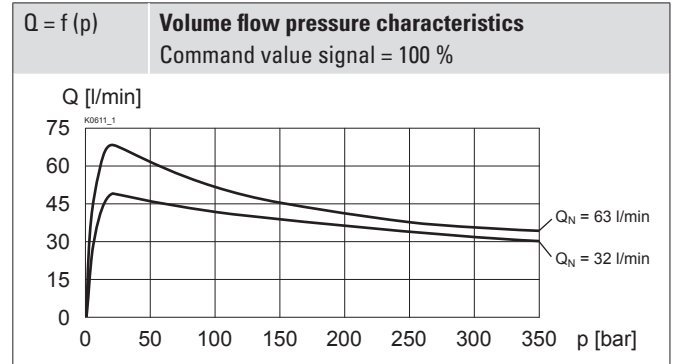
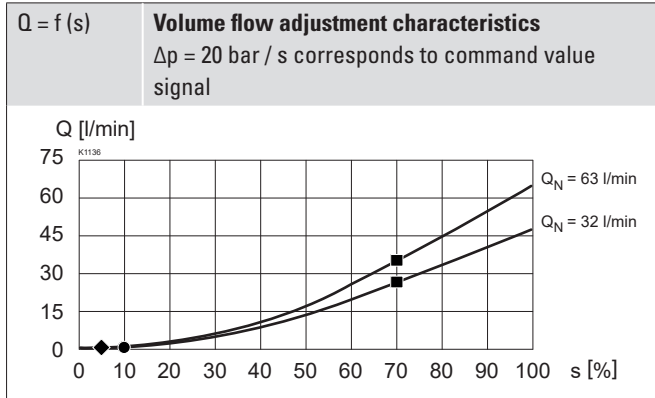

**PERFORMANCE SPECIFICATIONS**

 Oil viscosity  $\nu = 30 \text{ mm}^2/\text{s}$ 

**FACTORY SETTINGS**

Dither set for optimum hysteresis

- ◆ = Deadband: solenoid switched off at command value signal < 5 %
- = Opening pressure at command value signal + 10 %
- = Flow at  $\Delta p = 20 \text{ bar}$  at 70% command value signal

24 l/min	at nominal volume flow rate $Q_N$	32 l/min
34 l/min	at nominal volume flow rate $Q_N$	63 l/min

## DIMENSIONS

### With analog interface, 12 pole connector

Amplifier and controller

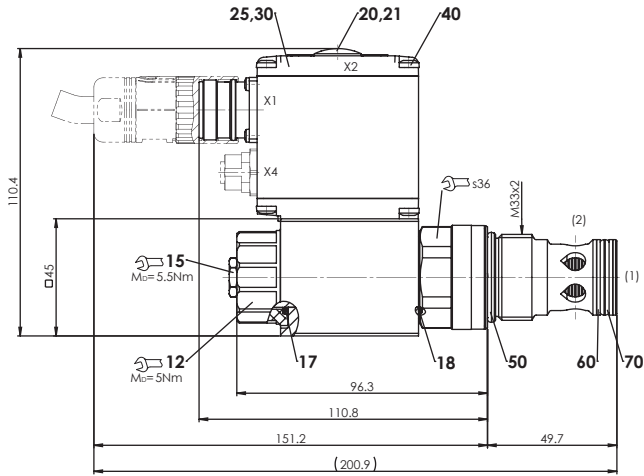

### With analog interface, 7 pole connector

Amplifier and controller

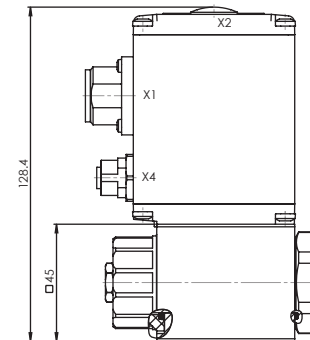

X4 (controller only)

### With fieldbus interface

Amplifier

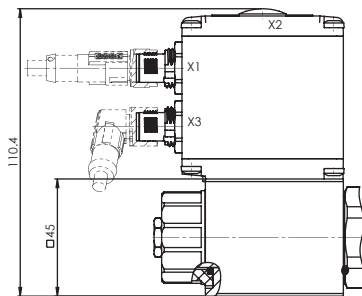

### With fieldbus interface

Controller

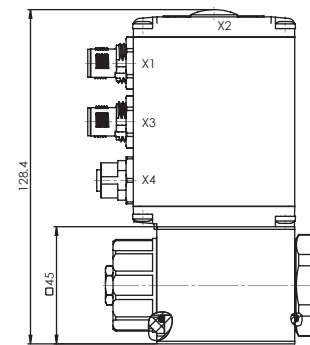

## HYDRAULIC CONNECTION

Cavity drawing according to ISO 7789-33-01-0-98

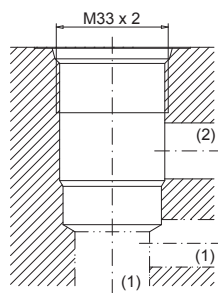

### Note!



For detailed cavity drawing and cavity tools see data sheet 2.13-1005

## PARTS LIST

Position	Article	Description
12	154.2700	Knurled nut
15	253.8000	Manual override HB4,5
17	160.2187	O-ring ID 18,72 x 2,62 (NBR)
18	160.2220	O-ring ID 21,95 x 1,78 (NBR)
20	223.1317	Dummy plug M16 x 1,5
21	160.6131	O-ring ID 13,00 x 1,5 (FKM)
25	062.0102	Cover
30	072.0021	Gasket 33,2 x 59,9 x 2
40	208.0100	Socket head screw M4 x 10
50	160.2298	O-ring ID 29,82 x 2,62 (NBR)
	160.6296	O-ring ID 29,82 x 2,62 (FMK)
60	160.2238	O-ring ID 23,81 x 2,62 (NBR)
	160.6238	O-ring ID 23,81 x 2,62 (FMK)
70	049.3297	Backup ring rd 24,5 x 29 x 1,4

## SEALING MATERIAL

NBR or FKM (Viton) as standard, choice in the type code

## COMMISSIONING

For DSV amplifiers as a rule no parameter adjustments by the customer are required. The plugs have to be connected in accordance with the chapter «Electrical connection».

Controllers are supplied configured as amplifiers. The adjustment of the mode of control and of the controller are carried out by the customer by means of the software adjustment (USB interface, Mini B).

Further information can be found on: «www.wandfluh.com».

Free- of charge download of the «PASO» software and the operation instructions for «DSV» hydraulic valves as well as the operation instructions CANopen Protocol resp. Profibus DP Protocol, with Device Profile DSP-408 for «DSV».

### Note!



The mating connectors and the parameterisation cable are not part of the delivery. Refer to chapter «Accessories».

## STANDARDS

Cartridge cavity	ISO 7789
CANopen	DRP 303-1
Profibus DP	IEC 947-5-2
Protection class	EN 60 529
Contamination efficiency	ISO 4406

## ACCESSORIES

Parameterisation software	See start-up
Parameterisation cable for interface USB (from plug type A on Mini B, 3 m)	Article no. 219.2896

### Mating connector (plug female) for analog interface

straight, soldering contact M23, 12 pole	Article no. 219.2330
angled, soldering contact, M23, 12 pole	Article no. 219.2331
straight, soldering contact, 7 pole	Article no. 219.2335

Flange body / sandwich plate NG10	Data sheet 2.6-760
Threaded body	Data sheet 2.9-205
Technical explanations	Data sheet 1.0-100
Filtration	Data sheet 1.0-50

### Attention!



Auxiliary conditions for the cable:

- External diameter 12 pol: 3,5...14,7 mm
- External diameter 7 pol: 8...10 mm
- Wire cross section max. 1 mm<sup>2</sup>
- Recommended wire cross section:  
0...25 m = 0,75 mm<sup>2</sup> (AWG18)  
25...50 m = 1 mm<sup>2</sup> (AWG17)

## SURFACE TREATMENT

- ◆ The cartridge body is gas-nitro-carburised
- ◆ The slip-on coil is zinc- / nickel-coated
- ◆ The electronics housing / chassis is made of aluminium

## INSTALLATION NOTES

Mounting type	Screw-in cartridge M33 x 2
Mounting position	Any, preferably horizontal
Tightening torque	M <sub>D</sub> = 80 Nm Screw-in cartridge M <sub>D</sub> = 5 Nm knurled nut