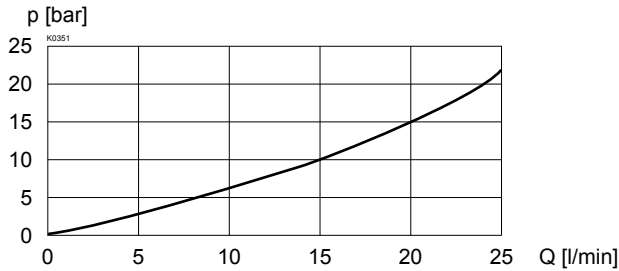
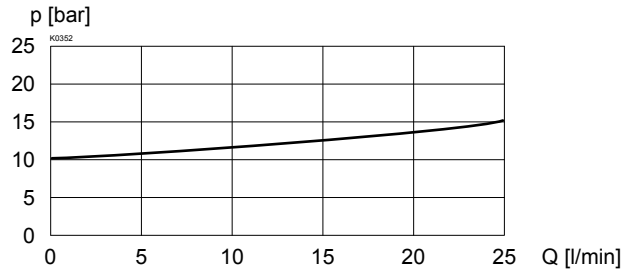
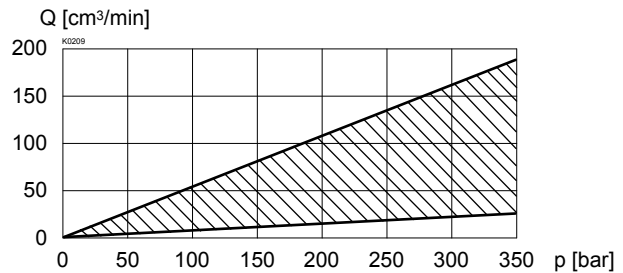
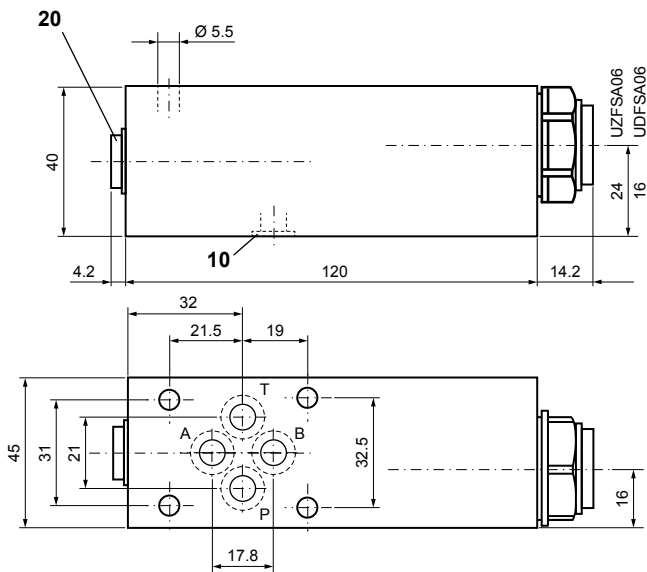

CHARACTERISTICS Oil viscosity $\nu = 30 \text{ mm}^2/\text{s}$
 $\Delta p = f(Q)$ Pressure drop-volume flow curve
 2-way operation

 $\Delta p = f(Q)$ Pressure drop-volume flow curve
 3-way operation

 $Q_L = f(p)$ Leakage volume flow curve

DIMENSIONS

SCREW-IN CARTRIDGES INSTALLED

The following screw-in cartridges are used in the sandwich body:

Type	Designation	Data sheet no.
UZFPM22	2-way operation	2.5-630
UDFPM22	3-way operation	2.5-630

PARTS LIST

Position	Article	Description
10	160.2093	O-ring ID 9,25 x 1,78
20	238.2406	Locking screw VSTI G1/4"-ED

ACCESSORIES

Thread connection plates and rows of flange plates register 2.9

Technical explanation see data sheet 1.0-100