

TECHNICAL EXPLANATION

SWITCHING SOLENOIDS

For use in hydraulic systems

Contents

- | | |
|---------------------------------|-----------------------------------|
| 1. Foreword | 4. Design and test specifications |
| 2. Type of solenoids | 4.1. Type testing |
| 3. Explanation of terms | 4.2. Component testing |
| 3.1. Force | 5. Installation guidelines |
| 3.2. Stroke | 6. Normal operating conditions |
| 3.3. Work | 6.1. Deviations |
| 3.4. Electrical voltage | 7. Durability |
| 3.5. Electrical current | 8. Liability |
| 3.6. Electrical power | |
| 3.7. Frequency | |
| 3.8. Expressions of time | |
| 3.9. Expressions of temperature | |
| 3.10. Functions | |
| 3.11. Protection concepts | |

1. Foreword

The technical explanation aims to clarify and define the expressions regarding switching solenoids which are found in the solenoid or valve data sheets. Design and test specifications, installation guidelines and operating conditions are also explained. Refer also to VDE 0580.

2. Type of solenoids

Control Solenoid

Single stroke solenoid (compressing, longitudinal movement), whose armature performs a stroke movement, effected by electromagnetic force, from an initial stroke position to an end stroke position. Re-setting is done by external forces (e.g. springs).

Pressure-tight solenoid (wet solenoid)

The armature housing can be pressurised. The armature is pressure-compensated. The maximum pressure values (static and dynamic) are to be found in the data sheets.

Direct-current solenoid

Solenoid with voltage winding, in which a current is set which is dependent on the terminal voltage and the field resistance. Supply is from the d.c. voltage network.

Alternating-current solenoid

Direct-current solenoid with integral single-phase, full-wave rectifier. Supply is from an a.c. voltage network.

Hydraulic solenoid

Solenoid designed for controlling hydraulic valves. Special features are the matching of the magnetic force- stroke curve to the counterforce (spring force curve), the pressure-tight armature housing and the division of the solenoid stroke into working stroke and no-load stroke.

3. Explanation of Terms

3.1. Force

Solenoid force (F)

The useable proportion, i.e. minus friction, of the force that is generated in the solenoid in the direction of the stroke. It applies to the normal running temperature of the field coil and to 90% of the nominal voltage.

Holding force (F_H)

The solenoid force in the end stroke position.

Restoring force (F_R)

The force required to return the armature to the initial stroke position, following disconnection.

3.2. Stroke

Initial stroke position (s_1)

The position of the armature before the beginning of the stroke movement or after resetting.

End stroke position (s_2)

The position of the armature after completion of the stroke movement (designed into the solenoid.)

Solenoid stroke (s)

The distance covered between the initial stroke position and the end stroke position.

No-load stroke (s_L)

The first part of the stroke movement, in which the solenoid is not working against any external force (e.g. springs).

Working stroke (s_A)

The second part of the stroke movement in which the solenoid, when part of a hydraulic valve, must work against an external force (e.g. springs). The working stroke is set, depending on the type of solenoid.

3.3. Mechanical Energy

Stroke energy (W)

Is the integral of the solenoid force F over solenoid stroke s (Fig. 1).

Working stroke energy (W_A)

The working capacity of a solenoid in the working stroke, that can be represented by a simplified surface (trapezium), Fig 2. Given in the data sheet.

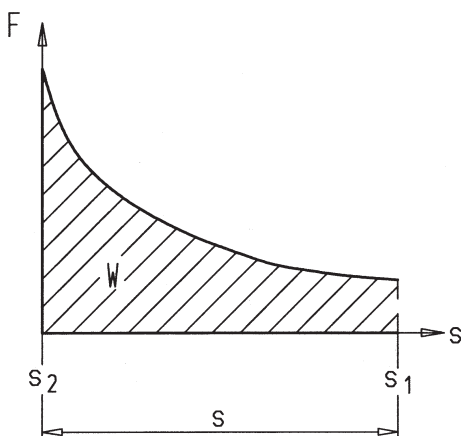

Fig. 1

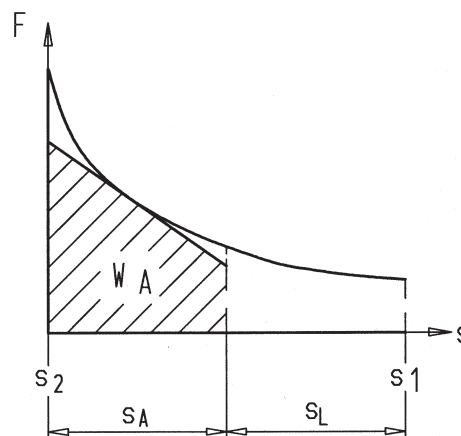

Fig. 2

3.4. Electrical voltage

Voltage data refer to the arithmetical mean for d.c. voltage and the rms value for a.c. voltage.

Rated voltage (U_N)

Voltage (a.c. or d.c. voltage) for which the solenoid has been designed.

Voltage change (U_N)

Deviation from the rated voltage. This is expressed in percentage of rated voltage. The voltage change on the valve data sheet may be smaller than the one on the solenoid data sheet because of the hydraulic function.

3.5. Electrical current

Current data refer to the arithmetical mean for d.c. voltage and the rms value for a.c. voltage.

Nominal current (I_N)

Refers to the nominal voltage, 20 C coil temperature and nominal frequency.

3.6. Electrical power

Nominal wattage (P_N)

Power consumption at rated voltage and a coil temperature of 20 C.

3.7. Frequency

Rated frequency (f_N)

Frequency for which the solenoids were designed when supplied from the a.c. voltage network.

3.8. Expressions of time

Continuous operation (DB)

The operation whose duty time is so long that the steady-state operating temperature is reached.

Intermittent operation (AB)

The operation where the duty time and the currentless interval alternate in regular or irregular succession, but where the intervals are so short that the device does not cool down to its reference temperature.

Short-time operation (KB)

The operation where the duty time is so short that the steady-state operating temperature is not reached. The currentless interval is so long that the device cools down practically to its reference temperature.

Duty time (ED)

Time between switching the exciter current on and off.

Currentless interval (SP)

Time between switching the exciter current off and on.

Cycle time (SD)

Sum of duty time and currentless interval.

Relative duty time (% ED)
(fixed intermittent operation)

Ratio of duty time to cycle time, expressed as a percentage.

$$\% \text{ ED} = \frac{\text{ED}}{\text{ED} + \text{SP}} \times 100$$

Preferred values for relative duty time (ED) are: 5, 15, 25, 40% . 100% ED equals continuous operation.
Preferred values for maximum cycle time are: 2, 5, 10, 30 min.
An example of the additional designation given to solenoids with relative duty time is as follows: 40% ED / 5 min.

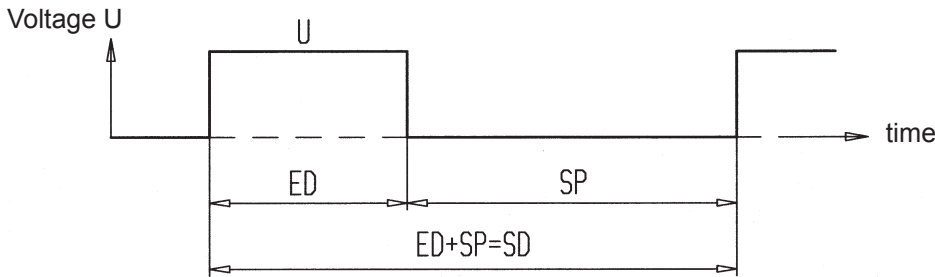

Fig. 3

!! Warning !! Solenoids with relative duty time have a higher solenoid force than standard solenoids but also greater power consumption. So that the permissible excess temperature limit is not exceeded, these solenoids may only be used for fixed intermittent operation and not for continuous operation.

Rise time t_1

The sum of response delay time and stroke time.

Response delay time t_{11}

The time from switching on the exciter current to the beginning of armature movement.

Stroke time t_{12}

The time from the beginning of armature movement from the initial stroke position to the arrival at the end stroke position.

Fall time t_2

The sum of fall delay time and return time.

Fall delay time t_{21} (dwell time)

The time from switching off the exciter current to the beginning of the return movement of the armature.

Return time t_{22}

The time from the beginning of the return movement of the armature up to arrival at the initial stroke position.

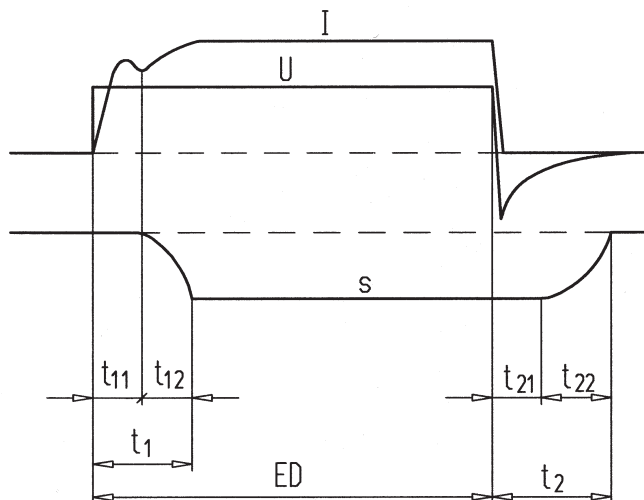

Fig. 4

Notes on switching times

The switching times given in the data sheets have been calculated at rated voltage and normal operating temperature and during operation with a load equal to 70% of the rated solenoid force. These times can vary when different media are used (viscosity) and when operating against different forces.

Switching frequency (S_n)

Number of complete on and off switching procedures per hour.

3.9. Expressions of temperature

Ambient temperature (ϑ_{13})

Average temperature of the solenoid environment.

Steady-state operating temperature (ϑ_{23})

Temperature of the solenoid occurring when heat input and dissipation are equal.

Reference temperature (ϑ_{11})

Steady-state operating temperature in currentless state during proper use. The maximum permissible reference temperature is given in the data sheets. Most of the time the reference temperature is different from the ambient temperature, since it is also influenced by the temperature of the medium (cooling or warming effect).

Upper limit temperature (ϑ_{21})

The highest permissible temperature for the solenoid.

Lower limit temperature (ϑ_{12})

The lowest permissible temperature for the solenoid.

Excess temperature limit ($\Delta\vartheta_{33}$)

Maximum permissible value for the difference between the temperature of the solenoid or one of its components and the reference temperature (coolant).

Medium temperature (ϑ_M)

Temperature of the medium in the solenoid.

Normal running temperature (BZ)

Calculated effective excess temperature plus reference temperature.

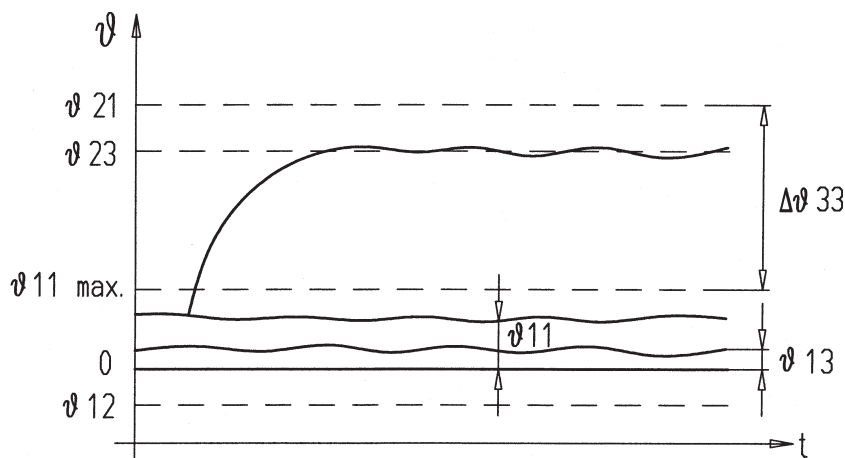

Fig. 5

3.10. Functions

Solenoid Force-Stroke (F=f(s))

The solenoid force - stroke curve for control solenoids designed for the control of hydraulic valves rises towards the end stroke position and is constructed in accordance with the spring counterforce.

The values given in the data sheets apply to the normal running temperature of the field coil at 90% nominal voltage

3.11. Protection concepts

Protection class

A protection class I electromagnetic device is a device whose live components have only basic insulation and are equipped with a protective earth terminal.

Type of protection

DIN 40 050 protection types apply with regards to protection from foreign bodies and water.

Insulation class

The coil insulation material may only heat up to a fixed upper limit temperature. The limit temperatures specified in VDE 0580 Art. 33 Table 4 apply.

4. Design and test specifications

4.1. Type testing

Type testing encompasses the following tests:

- Terminals to VDE 0580 Art. 29f,
- Protective earth terminals to VDE 0580 Art. 30d,
- Enclosures to VDE 0580 Art 31b,
- Creepage distances and clearances to VDE 0580 Art. 32b,
- Temperature-rise test to VDE 0580 Art. 34 to 36,
- Voltage testing to VDE 0580 Art. 37 to 40,
- Insulation resistance to EN 60204 (13.1 insulation test)
- Functional test to VDE 0580 Arts. 42 to 44.

4.2. Component testing

Component testing encompasses the following tests:

- Testing the protective earth terminals to VDE 0580 Art. 30d,
- Voltage testing to VDE 0580 Arts. 37 to 40,
- Tightness test to WAG guidelines
- Functional test to WAG guidelines
- Markings to VDE 0580 Art. 46g.

Note

The voltage test may only be repeated on d.c. solenoids in special cases (e.g. acceptance tests).

Even here, only 80% of the prescribed test voltage should be applied. The voltage test may not be repeated on a.c. solenoids because of the integral rectifier.

5. Installation guidelines

Mechanical

The solenoids are to be properly installed in the valve or similar component using the proper mounts (see data sheets for terminal diagram) and keeping to the minimum external dimensions as stated in the data sheets. Only in this way can optimum tightness and sufficient heat dissipation be guaranteed.

Electrical

The earthing screw in the plug must be connected up, or other means of earthing the device must be ensured. The plug has to be professionally assembled and attached.

6. Normal operating conditions

Humidity

Relative humidity of the ambient air must not exceed 50% at 40 C. Higher degrees of humidity are permitted at lower temperatures, e.g. 90% at 20 C. Measures should be taken to protect the device from occasional moderate build-up of condensation.

Temperature

The reference and medium temperatures that are quoted on the data sheets should not be exceeded.

Switching frequency

The maximum switching frequency stated in the data sheets should not be exceeded.

Environment

The environment should not be subjected to shocks, foreign bodies and water at levels exceeding those for which the protection is designed (DIN 40050). The ambient air should also not be contaminated by aggressive gases or vapours and should not contain salt.

Duty cycle

WAG solenoids are designed as standard for continuous operation (100% ED) as defined in Section 3.8. This means that the solenoid's steady-state operating temperature is reached - usually after approx. 1.5 - 2 hours. A currentless interval must follow this, particularly if there are high ambient or reference temperatures. This allows the solenoid to cool down to its reference temperature before being switched back on again. We can supply reduced power solenoids for continuous operation applications where the duty cycle is longer than the one mentioned above.

Medium

Neutral fluid media are suitable. If using oil one must ensure that it contains no aggressive substances, since these can attack seals and materials, Mineral-based oils are usually very suitable. The medium must be well refined and contain no contamination particles.

6.1. Deviations

If deviations from normal operating conditions occur in practice, then suitable measures must be taken, such as a higher degree of protection, special surface protection, sealing the solenoids, reduced power, etc. In such cases, please contact us, stating the prevailing operating conditions.

7. Durability

The service life of the device and the service life of wearing parts of electromagnetic devices depend not only on their design but also to a considerable extent on external conditions, such as installation location, type and degree of loading. Therefore no standard predictions can be made about service life (requirements and testing).

8. Liability

No modifications may be made to the solenoids. The solenoids may not be dismantled. The normal operating conditions as described in Section 5 should not be deviated from. We cannot accept liability or honour the guarantee if the above points are not followed.