



VALVES IN STAINLESS **K9 EXECUTION**

VALVE ACTUATION

MKY45_18x60_K9	Solenoid coil	Ex-protection
----------------	---------------	---------------

VALVES IN FLANGE CONSTRUCTION

WDMFA06_K9	Solenoid operated spool valve	Slip-on coil
WDYFA06_K	Solenoid operated spool valve	Ex-protection
WDTFA06_K9	Spool valve	Roller operated
WDBFA06_K9	Prop. spool valve	Ex-protection
AEXd_206_K	Solenoid poppet valve	Ex-protection

VALVES IN CARTRIDGE CONSTRUCTION

SDSPM22_K9	Solenoid operated poppet valve cartridge	Direct operated
SDYPM22_K	Solenoid operated poppet valve cartridge	Ex-protection
SLYPM22-FG_K	Solenoid operated poppet valve cartridge	Ex-protection
MV_PM22_K9	Pressure reducing cartridge	Manually operated
BV_PM22_K9	Pressure relief cartridge	Manually operated
BA_PM22_K9	Pressure relief cartridge	Manually operated
DN_PM18_K9	Throttle cartridge	Direct operated

DESCRIPTION

In the field of underground mining, in use at sea or in mobile machines, the focus is on robust and proven technology that meets the high corrosion protection requirements. Valves of various construction types and with different functions are available for this purpose. The valves are made of stainless and acid-resistant steel.



Solenoid coil Ex d II C, MKY45_18x60_K9

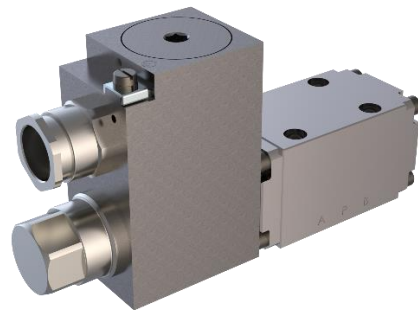

Solenoid operated spool valve stainless WDYFA06_K



Throttle cartridge stainless DN_PM18_K9



K8: 500 -1000 H SALT SPRAY TEST

All external elements on the valve, which are in contact with the environment, have a zinc-nickel coating or are made of stainless materials. Control knobs and partially knurled nuts are made of plastic. K8 will increasingly become the standard in the future. Only the valve flange bodies are painted and the screws zinc coated.

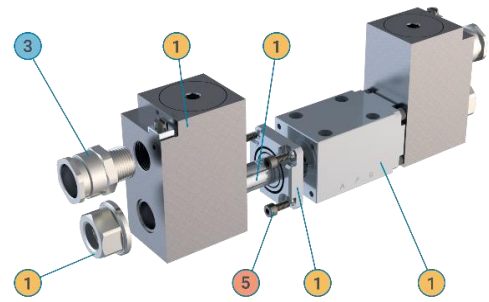

K9: > 1000 H SALT SPRAY TEST

All external elements, apart from the solenoids, are made of stainless materials. Wherever possible, stainless, acid-resistant AISI 316L steels are used. The solenoids are zinc-nickel coated.

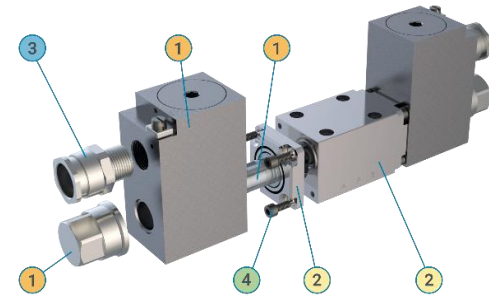

K10: > 1000 H SALT SPRAY TEST

All external elements are made of stainless materials or coated with stainless materials. Wherever possible, stainless, acid-resistant AISI 316L steels are used.

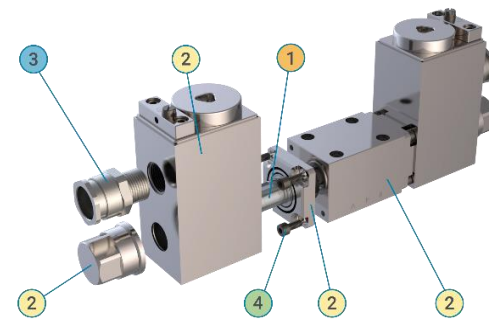

Pos	Corrosion protection
1	Zinc-nickel coated
2	Stainless steel AISI 316L
3	Nickel coated brass
4	Stainless steel screws
5	Zinc coated screws

