

OPERATING INSTRUCTIONS SD6

PROFIBUS-DP Device-Profile in accordance with Fluid Power Technology

Version 2.1

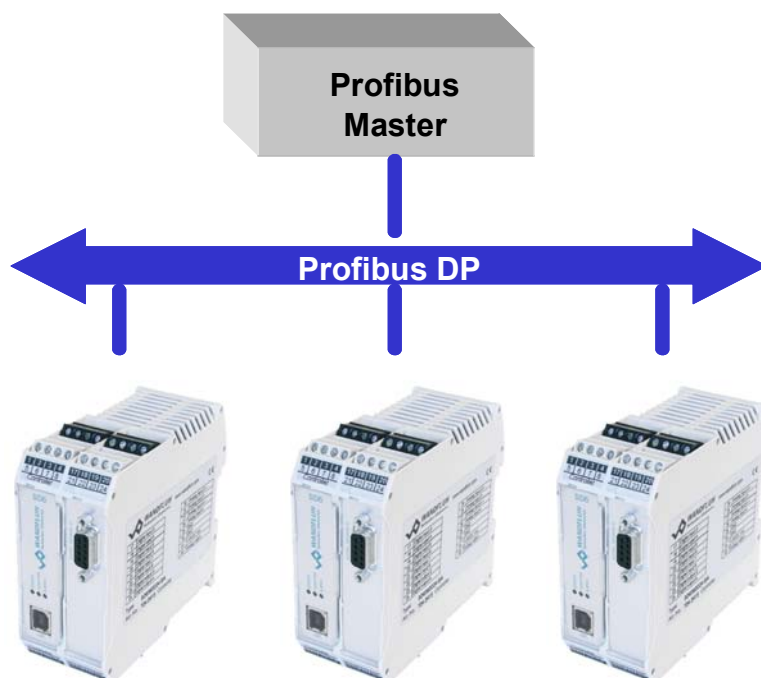

0 Contents

0	Contents	2
1	PROFIBUS-DP Technology	5
1.1	General.....	5
1.2	Master and Slaves.....	6
1.3	Data exchange	6
1.4	Communication from words and double words.....	6
1.5	GSD Files	6
2	General of cyclical data exchange	7
2.1	Data structure.....	7
2.2	Telegram structure by the cyclical data communication	7
2.3	Available telegrams	7
2.4	General.....	7
3	Product Description	8
3.1	General.....	8
3.2	Technical Data	8
3.2.1	Transmission technology and baudrate.....	8
3.3	Operating and Indicating elements	8
3.4	Fieldbus Settings.....	9
3.5	Fieldbus Diagnostics	10
3.6	Fieldbus-Parameter.....	12
3.7	Connection Example	12
3.8	Parameterisation	12
4	Description of the Function of Device Profile DSP-408	13
4.1	Device architecture	13
4.2	Device Control.....	14
4.2.1	Local control.....	14
4.2.2	Operating mode	14
4.2.3	State machine	16
4.3	Program Control.....	19
4.3.1	Specialmode	20
4.4	Cyclical process data exchange (PZD).....	22
4.4.1	Telegram types	22
4.4.2	Receive data (Master → Slave, command values)	26
4.4.3	Transmit data (Slave → Master, feedback values).....	26
4.5	Cyclical parameter data exchange (PKW).....	27
4.5.1	Description of the parameter transmission process	29
4.6	Scaling.....	30
4.6.1	Internal bus resolution	31
4.7	Parameter description	32
4.7.1	Parameter overview.....	33
4.7.2	Error Code	39
4.7.3	Control Word.....	40
4.7.4	Status Word	41
4.7.5	Device mode	42
4.7.6	Device control mode	42
4.7.7	Device local.....	42
4.7.8	Capability	43
4.7.9	Store Parameter.....	43
4.7.10	Reset Default	44
4.7.11	Mode of operation	44
4.7.12	Error handling	45
4.7.13	Special mode	45
4.7.14	Command value.....	45
4.7.15	Command value B	46

4.7.16	Imin A.....	47
4.7.17	Imax A.....	47
4.7.18	Imin B.....	48
4.7.19	Imax B.....	48
4.7.20	Min. Interface transducer.....	49
4.7.21	Max. Interface transducer.....	49
4.7.22	Min. Reference transducer.....	50
4.7.23	Max. Reference transducer.....	50
4.7.24	Max. Reference transducer digital.....	51
4.7.25	Ramp type.....	51
4.7.26	Ramp A up.....	52
4.7.27	Ramp A down.....	53
4.7.28	Ramp B up.....	53
4.7.29	Ramp B down.....	54
4.7.30	Speed positive.....	54
4.7.31	Speed negative.....	55
4.7.32	Deadband compensation type.....	55
4.7.33	Deadband threshold A.....	56
4.7.34	Deadband threshold B.....	56
4.7.35	Dither type.....	57
4.7.36	Dither Frequency.....	57
4.7.37	Dither Amplitude.....	58
4.7.38	System control.....	58
4.7.39	Output Solenoid A.....	59
4.7.40	Output Solenoid B.....	59
4.7.41	Imin always active.....	60
4.7.42	Solenoid 'In Position'.....	60
4.7.43	Signal type feedback value.....	61
4.7.44	Used input feedback value.....	61
4.7.45	Cablebreak feedback value.....	61
4.7.46	Displayed unit.....	62
4.7.47	SSI-Transducer resolution.....	62
4.7.48	SSI-Transducer offset.....	63
4.7.49	SSI-Transducer bit count.....	63
4.7.50	Start/Stop Transducer type.....	63
4.7.51	Start/Stop Transducer speed of sound.....	64
4.7.52	Start/Stop Transducer offset.....	64
4.7.53	Target window type.....	65
4.7.54	Target window threshold.....	65
4.7.55	Target window delay time.....	66
4.7.56	Trailing window type.....	66
4.7.57	Trailing window threshold.....	67
4.7.58	Trailing window delay time.....	67
4.7.59	Solenoid off window threshold.....	68
4.7.60	Solenoid off window delay time.....	68
4.7.61	Internal resolution.....	69
4.7.62	Command Feed forward value.....	69
4.7.63	Velocity feed forward value.....	70
4.7.64	I-part outside I-window.....	70
4.7.65	P-amplification positive.....	71
4.7.66	P-amplification negative.....	71
4.7.67	Integrator type.....	72
4.7.68	I-time positive.....	72
4.7.69	I-time negative.....	73
4.7.70	I-window outside positive.....	73
4.7.71	I-window outside negative.....	74
4.7.72	I-window inside positive.....	74

4.7.73	I-window inside negative	75
4.7.74	D-time positive	75
4.7.75	D-time negative	76
4.7.76	D-amplification positive	76
4.7.77	D-amplification negative	77
4.7.78	Feedback value	77
4.7.79	Feedback value pressure	78
4.7.80	Control deviation	78
4.7.81	Control deviation pressure	79
4.7.82	Characteristic optimisation	80
4.7.83	Characteristic optimisation X-axis	80
4.7.84	Characteristic optimisation Y-axis	82
4.7.85	Characteristic optimisation of solenoid choice	83
4.7.86	Characteristic optimisation of base	83
5	Commissioning	84
5.1	Step by step instructions for the first commissioning	84
5.1.1	Test the hydraulic system	84
5.1.2	Connect the measuring system (only SD6 controller)	84
5.1.3	Adjust the mode of operation (only SD6 amplifier)	84
5.1.4	Test the fieldbus	85
5.1.5	Test the control via the fieldbus	85
5.2	Presupposition for the DP-Slave controller card	85
5.3	Presupposition and information for the Fieldbus master	86
5.4	Delivery state	86
5.5	Parameterisation	86
5.6	Setting the preset value via Fieldbus	87
5.7	Start after an error	87
6	Diagnostic and error detection	88
6.1	Diagnostic about the Fieldbus	88
7	Version index	88

1 PROFIBUS-DP Technology

1.1 General

PROFIBUS-DP is a vendor-independent, open field bus standard for a wide range of applications in manufacturing and process automation. Vendor-independence and openness are ensured by the international standards EN 50170 and EN 50254.

PROFIBUS-DP offers functionally graduated communication protocols (Communication Profiles), WANDFLUH is using for the SD6 Electronics the communication profile **DP** (decentralised periphery).

PROFIBUS-DP is optimised for fast, time critical data exchange on the field layer. The Fieldbus is used for cyclical and not cyclical data exchange between a Master and its slaves.

PROFIBUS-DP can be used for different device profiles. WANDFLUH is using for the SD6 Electronics the device profile DSP-408 "Device Profile Fluid Power Technology".

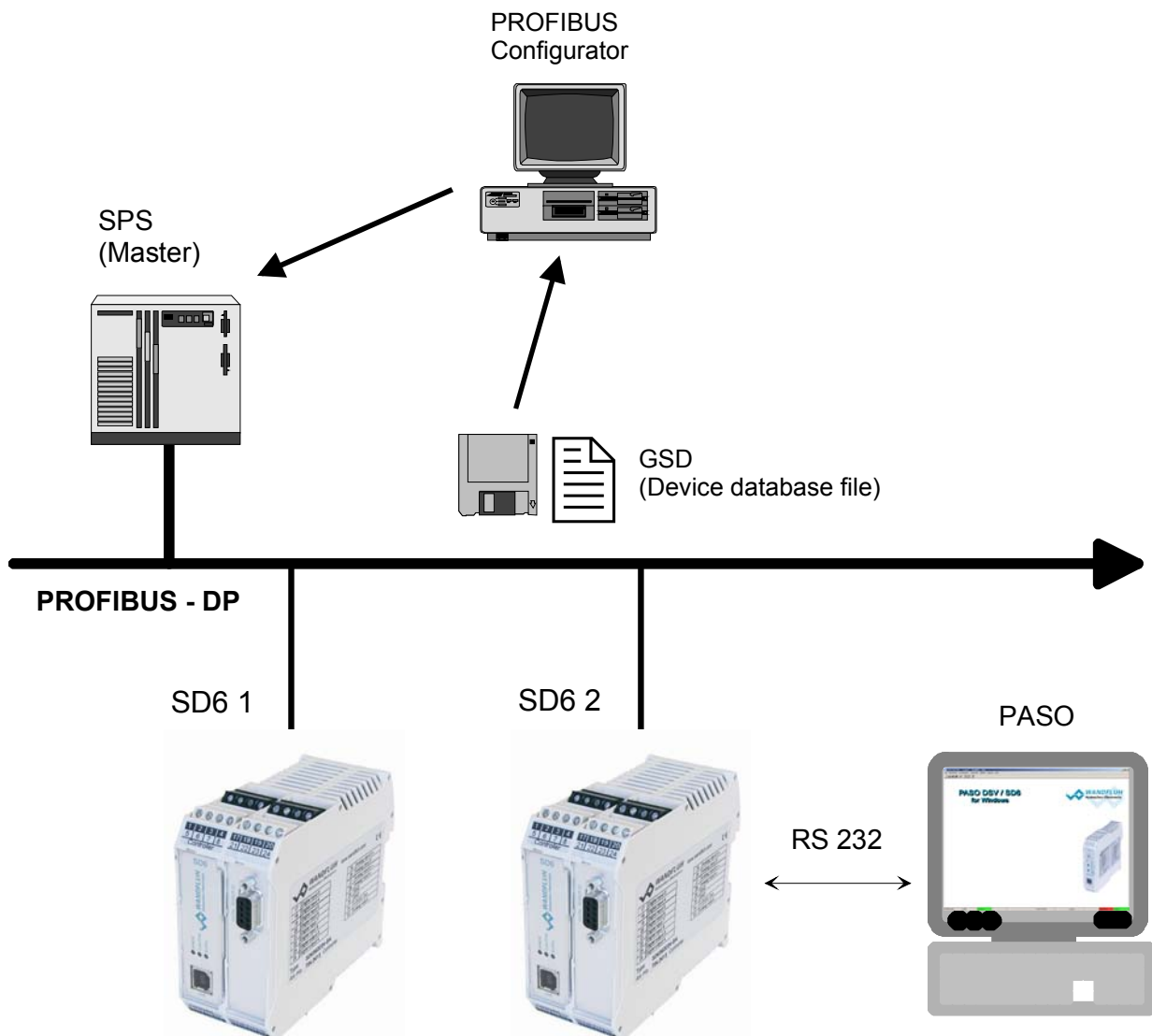

1.2 Master and Slaves

With -DP, once differs between Master- and Slave-Devices:

- **Master (active Fieldbus participants)**
These devices determine the data exchange on the Fieldbus and are named therefore as active Fieldbus participant
- **Slaves (passive Fieldbus participants)**
These devices can only receive messages and send data and messages to the Master only on a request.

The WANDFLUH SD6 Electronics are always slaves. In the further documentation, this slave will be named always DP-Slave controller card.

1.3 Data exchange

The data exchange is made through the Master - slave procedure, where the drives are always the slaves. This permits a very fast cyclical data exchange.

For the parameterisation, diagnostic and error handling during the current cyclical data exchange, also not cyclical communication functions are used in additional.

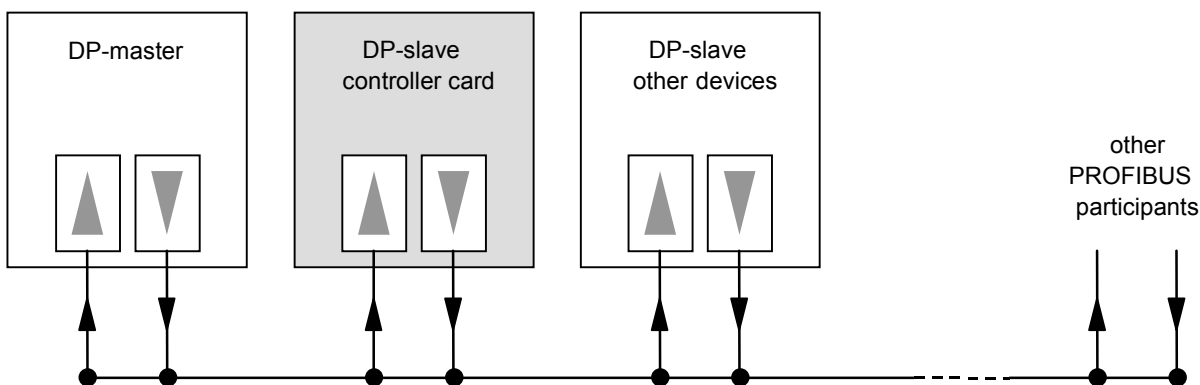

1.4 Communication from words and double words

All used size of words and double words are transmitted in the little endian format. Therefore, the low byte resp. the low word will be transmitted before the high byte resp. the high word (word = 16 bit, double word = 32 bit).

1.5 GSD Files

The characteristic communication features of a PROFIBUS-DP device are defined in the form of an electronic data sheet (Device database, GSD file). WANDFLUH makes available the corresponding GSD file for the DP-Slave controller card.

The GSD files expand the open communication right to the user level. All modern planning tools make it possible to read-in the GSD files during the configuration. As a result, the integration into the PROFIBUS-DP system becomes simple and user friendly.

2 General of cyclical data exchange

2.1 Data structure

The data structure by the cyclical data communication is shared into 2 parts, which will be transmitted in each telegram:

- **Parameter data exchange (PKW, parameter channel)**
 This part of the telegram serves for read and/or write of parameters and for read of error messages.
- **Process data exchange (PZD, process data)**
 This part contains the control word, preset values resp. additional information and feedback values. With the process data, the following data will be transmitted:
 - Control words and preset values (Master => Slave)
 - Status words and feedback values (Slave => Master)

During the boot up of the Fieldbus system, the Master determines the used telegram type. The selected telegram type will be send automatically to the DP-Slave controller card via the configuration telegram.

2.2 Telegram structure by the cyclical data communication

The telegrams by the cyclical data communication have the following structure:

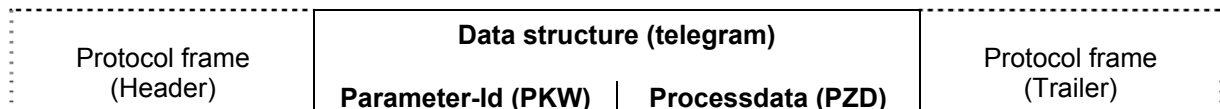

2.3 Available telegrams

For a description about all available telegram types refer to section "Telegram types" page 22.

2.4 General

- The selection between the different telegram types with different data length is depending on the performance of the device in the Fieldbus compound.
- For a detailed description about each parameter please refer to section "Parameter description" page 32.

3 Product Description

3.1 General

The present operating instructions represent a PROFIBUS-DP specific extension of the SD6 Electronics operating instructions.

Remark: Please read the operating instructions of the SD6 Electronics beforehand.

3.2 Technical Data

The connection to the PROFIBUS-DP is made via the D-SUB connector on the front plate. The pin occupation correspond to the standard.

PROFIBUS-DP Interface	D-SUB-plug connector 9-pole female on front plate, in accordance with RS485 galvanic separated <ul style="list-style-type: none"> • Pin 3 = RxD/TxD-P (receive-/transmit data-positive, B-line) • Pin 8 = RxD/TxD-N (receive-/transmit data -negative, A-line) • Pin 5 = DGND (data transmitting potential Ground to 5V) • Pin 6 = VP (power supply of the bus terminator-P P5V)
------------------------------	--

The DP-slave controller card is using the PROFIBUS-DP V0 specifications.

3.2.1 Transmission technology and baudrate

The DP-Slave controller card detects automatically the adjusted baudrate on the Fieldbus. The following baudrates are possible:

9.6kBaud / 19.2kBaud / 45.45kBaud / 93.75kBaud / 187.5kBaud / 500kBaud / 1.5MBaud / 3.0MBaud / 6.0Mbaud / 12Mbaud

During the setup of the fields system, the Master will set baudrate uniform for all devices on the bus.

3.3 Operating and Indicating elements

The DP-Slave controller card is equipped with a front plate in its standard version. The front plate provides a socket USB type B for the connection to the parameterisation PASO and provides a 9-pole D-SUB plug for the PROFIBUS-DP interface.

3.4 Fieldbus Settings

The following settings can be made via the parameterisation software PASO:

- Bus Node Adress (write and read)
- Baudrate (read only)
- Telegram type (write and read)

This settings can be made in the menu item "Fieldbus_Fieldbus-Info".

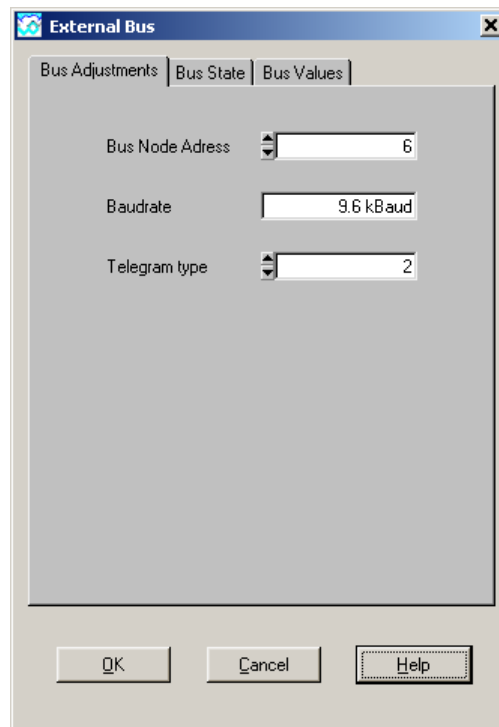

The following parameters can be set resp. will be displayed:

Field	Parameter description	Display
Bus Node Adress	With this parameter, the required node address for the DP-Slave controller card can be set. The value set is saved on the DP-Slave controller card in the non-volatile memory.	0 ... 126
Baudrate	The adjusted Baudrate will be displayed. During the setup of the fields system, the Master will set the Baudrate uniform for all devices on the bus.	9.6kBAud, 19.2kBAud, 45.45kBAud, 93.75kBAud, 187.5kBAud, 500kBAud, 1.5Mbaud, 3.0Mbaud, 6.0Mbaud, 12Mbaud
Telegram type	In the "Off Line"-mode, the required telegram type can be set. In the "On Line"-mode, the current telegram type will be displayed. For more information about the telegram type, please refer to section "Telegram types" page 22.	

3.5 Fieldbus Diagnostics

A diagnosis of the Fieldbus is possible at any time via the parameterisation software PASO. This takes place through the menu point "Fieldbus-Fieldbus-Info".

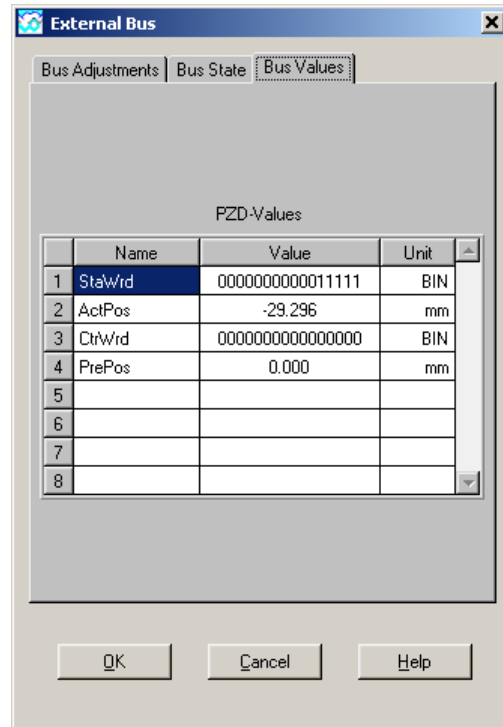
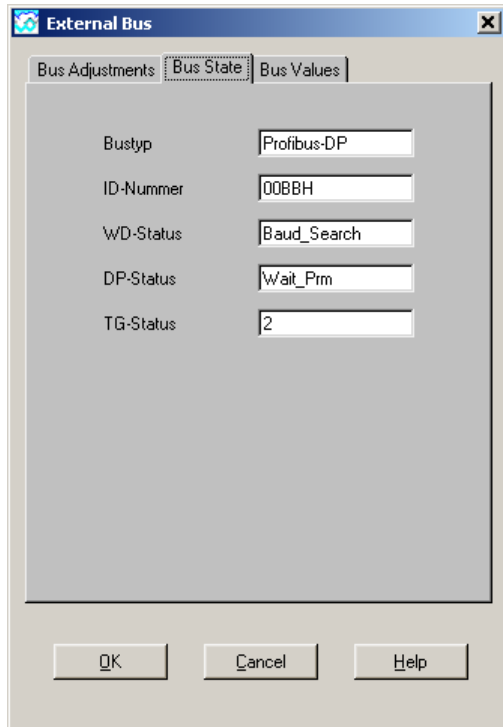

The following bus statuses are displayed:

Field	Parameter description	Display
Bus type	The type of the connected Fieldbus	PROFIBUS-DP
ID - number	The identification number of the DP-Slave controller card. This number is predefined fixed.	
WD-Status	<p>The communication on the Fieldbus is supervised permanent through the Watchdog. The current state of the Watchdog is displayed here.</p> <p>Baud_Search The baudrate will be searched</p> <p>Baud_Control The found baudrate will be checked</p> <p>DP_Control The found baudrate is ok. The Watchdog for the Fieldbus is active.</p>	<p>Baud_Search</p> <p>Baud_Control</p> <p>DP_Control</p>

DP-Status	<p>The DP-Slave controller card can be in different states. The current state will be displayed here.</p> <p>Wait_Prm After the start-up, the DP-Slave controller card is waiting for a parameter telegram. All other telegram types will not be handled. No data exchange is possible.</p> <p>Wait_Cfg The DP-Slave controller card is waiting for a configuration telegram. All other telegram types will not be handled. No data exchange is possible.</p> <p>Data_Exchange If the parameter telegram as well as the configuration telegram were ok, the data exchange via the Fieldbus is enable and possible.</p>	<p>Wait_Prm</p> <p>Wait_Cfg</p> <p>Data_Exchange</p>
TG-Status	The current telegram type will be displayed here	

The following bus values are displayed:

Field	Parameter description	Display
PZD-Values	In this table, the PZD-values will be displayed. The PZD-values are the real data on the bus. The displayed value depends on the selected telegram type.	

3.6 Fieldbus-Parameter

The fieldbus-specific settings can be made through parameterisation software PASO. This can be done in the menu item "Fieldbus_Fieldbus-Parameters".

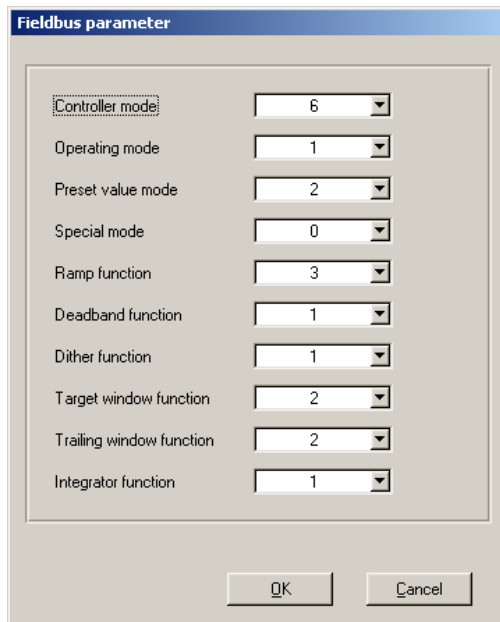

The following parameters are displayed:

Feld	Parameter Beschreibung
Device control mode	See „Device control mode“ page 42
Device local	See „Device local“ page 42
Device mode	See „Device mode“ page 42
Special mode	See „Special mode“ page 45
Ramp function	See „Ramp type“ page 51
Deadband function	See „Deadband compensation type“ page 55
Dither function	See „Dither type“ page 57
Target window function	See „Target window type“ page 65
Trailing window function	See „Trailing window type“ page 66
Integrator function	See „Integrator typ“ page 72

3.7 Connection Example

As a connection example, reference is made to the corresponding operating instructions of the SD6 Electronics.

All relevant digital I/O information is transmitted via the Fieldbus. Therefore no digital inputs should be connected from external.

3.8 Parameterisation

The DP-Slave controller card can be parameterised either through the PROFIBUS-DP or through the parameterisation software PASO.

4 Description of the Function of Device Profile DSP-408

The device profile explains the data and their format, which are exchanged between the PROFIBUS-DP Master and the DP-Slave controller card. The device profile is based on the specification of the profile „Fluid Power Technology“ as defined by the VDMA (the German Engineering Federation). The device profile has been defined for hydraulic devices, such as: proportional valves, hydrostatic pumps and hydrostatic drives.

4.1 Device architecture

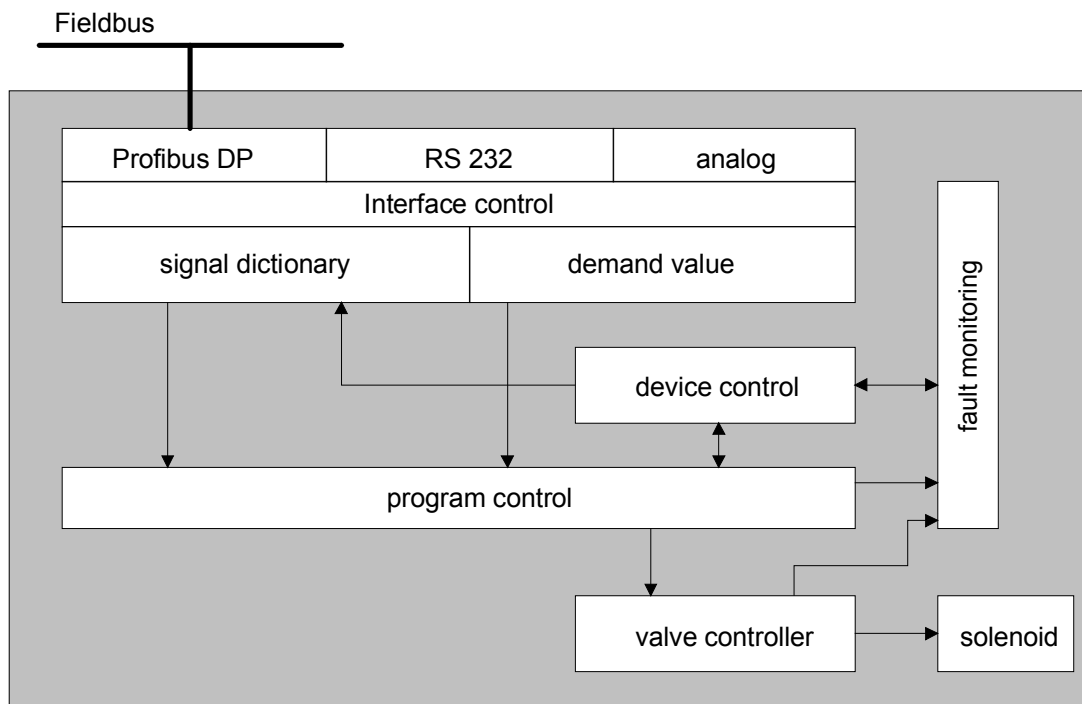

The DP-Slave controller card contains the complete Hardware of the SD6 Electronics. This Hardware includes the interface for the Fieldbus and the interface for the parameterisation software PASO. Also included are 2 solenoid outputs for the cylinder.

The Fieldbus control is made through a higher level Fieldbus Master.

The local control can be made either via digital in- and outputs or via the parameterisation software PASO.

4.2 Device Control

The following picture shows the principle function of the DP-Slave controller card.

4.2.1 Local control

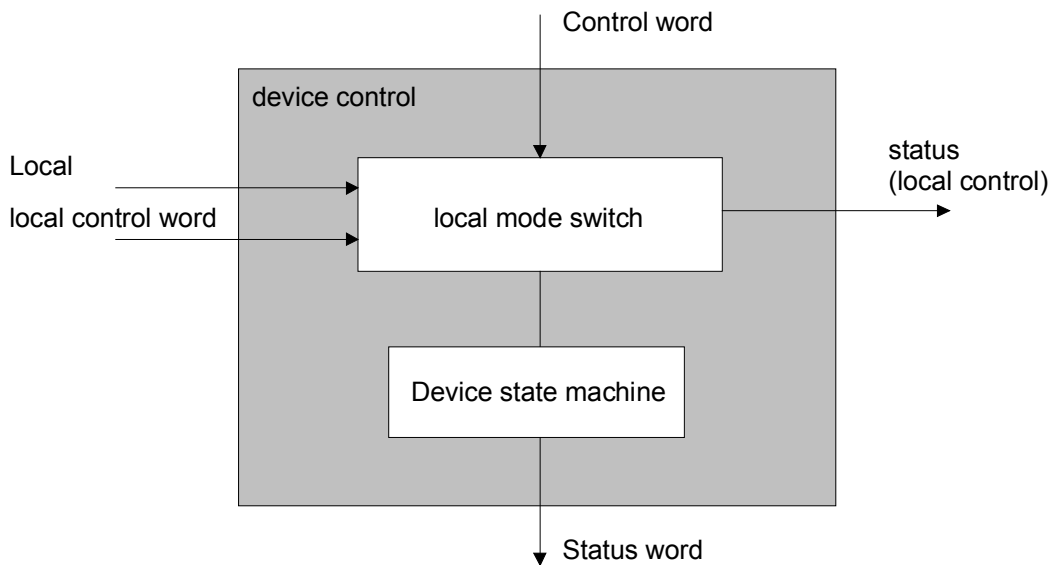

4.2.2 Operating mode

Local mode ("local")

In the local mode, the control commands and the current states will be set resp. displayed through the parameterisation software PASO. **Except of the parameter "Local", all values coming through the Fieldbus are ignored.** The local mode has 2 states: "Disabled" and "Enabled", switch over through the digital input.

To activate the local mode from the bus mode, the bus parameter "Device local=1" must be sent via the CAN-bus (condition: SD6-state "Init" or "Disabled").

PASO mode ("Remote PASO")

In the PASO mode, the control commands and the current states will be set resp. displayed through the parameterisation software PASO (equal to the local mode). The local mode has 2 states: "Disabled" and "Enabled", switch over through the PASO command "Enable" resp. "Disable".

To activate the PASO mode from the bus resp. local mode, the PASO command "PASO Control" must be activated (condition: SD6-state "Init" or "Disabled").

Bus mode ("Remote")

In the Bus mode, the control commands and the current states will be set resp. displayed through the Bus. The Bus mode has several states (refer to chapter "State machine" page 16), switch over through the Bus parameter "control word".

The SD6 parameterisation is possible either through the Bus or through the PASO.

To activate the Bus mode from the PASO mode, the PASO command "Local Control" must be activated (condition: SD6-state "Init" or "Disabled").

To activate the Bus mode from the local mode, the bus parameter "Device local=0" must be sent via the Bus (condition: SD6-state "Init" or "Disabled").

The picture on the next page shows the different possibilities of switch over the different states.

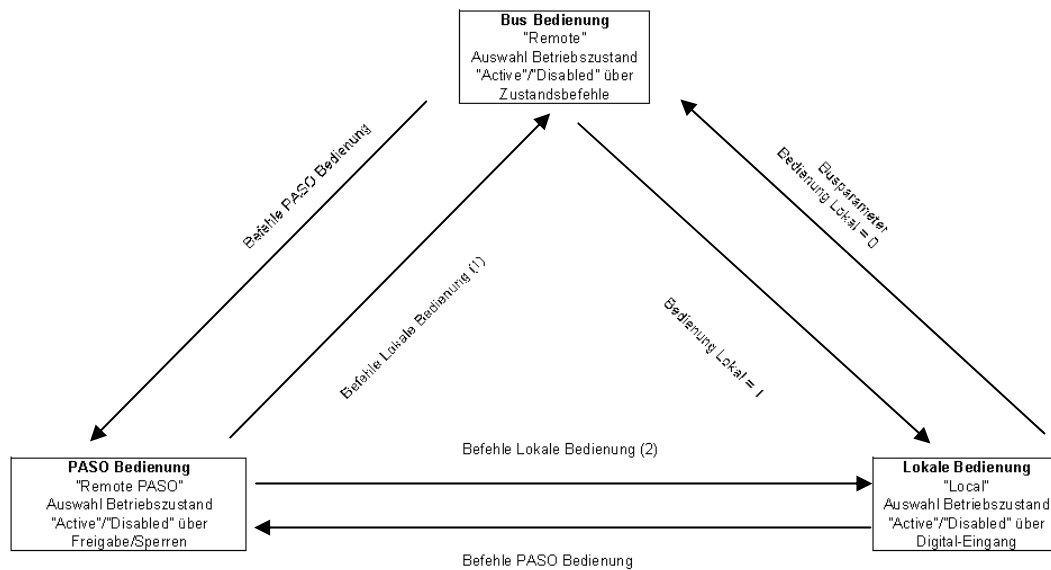

Verlassen eines Operationsmodus nur wenn DSV-Zustand auf Init oder Disabled

- (1) wenn Bedienung Lokal = 0
- (2) wenn Bedienung Lokal = 1

Im Bedienungszustand 'PASO Disabled' ist das Senden des Busparameters 'Bedienung Lokal' ebenfalls möglich

Operating mode

4.2.3 State machine

In the following, with the help of a status diagram it is described, how the start-up of the DP-Slave SD6 takes place and which statuses are reached when and how.

The following table describes the possible states and what is done in these states:

Zustand	description
NOT_READY	<ul style="list-style-type: none"> The supply voltage is present on the SD6 Self test is running The device functions are disabled
INIT	<ul style="list-style-type: none"> Device parameters can be set Initialisation of device parameters with stored values The device functions are disabled It's possible to activate the "PASO remote" mode
DISABLED	<ul style="list-style-type: none"> Device parameters can be set The device functions are disabled In this state "db_ControlMode" and "db_DeviceMode" can be set. It's possible to activate the "PASO remote" mode
HOLD	<ul style="list-style-type: none"> Device parameters can be set The last set-point value present is maintained active The set-point value of the status DEVICE_MODE_ACTIVE is not active Device modes setting is disabled
DEVICE_MODE_ACTIVE	<ul style="list-style-type: none"> Device parameters can be set The operating mode selected with the parameter "ControlMode" and the device mode selected with the parameter "DeviceMode" are active Changing the operating mode is not possible (the writing of the parameter "DeviceMode" is responded to negatively)
FAULT_HOLD	<ul style="list-style-type: none"> Device parameters can be set The feedback value present is read or the set-point value of the HOLD status is active To leave this state, the corresponding transitions in the table below have to be executed.
FAULT	<ul style="list-style-type: none"> Device parameters can be set The device functions are disabled To leave this state, the corresponding transitions in the table below have to be executed
FAULT_REACTION	<ul style="list-style-type: none"> This status is reached, if the device is not anymore ready for operation Device parameters can be set The device function can be disabled or enabled

The following table describes the transitions from one status to the next one:

Übergang	description	Controlwort Bit							
		7	6	5	4	3 R	2 M	1 H	0 D
TR_0	Switching-on the supply voltage	Internal transition							
TR_1	Device initialisation successfully completed	Internal transition							
TR_2	Bit "Disable" active	x	x	x	x	x	x	x	1
TR_3	Bit "Hold enable" active	x	x	x	x	x	x	1	1
TR_4	Bit "Device mode active enable" active	x	x	x	x	x	1	1	1
TR_5	Bit "Device mode active enable " not active	x	x	x	x	x	0	x	x
TR_6	Bit "Hold enable" not active	x	x	x	x	x	0	0	x
TR_7	Bit "Disable" not active	x	x	x	x	x	0	0	0
TR_8	Error present	Internal transition							
TR_9	Error reaction successful (HOLD active)	Internal transition							
TR_10	Error reset (return to the status DISABLED). The "reset fault" bit in the control word imperatively has to change from 0 to 1	x x x x 0 x 0 x							
		x x x x 1 x 0 x							
TR_11	Error reset (return to status HOLD). The "reset fault" bit in the control word imperatively has to change from 0 to 1	x x x x 0 x 1 x							
		x x x x 1 x 1 x							
TR_12	Error reaction successful (DISABLED active)	Internal transition							

RMHD = R: Controlwort "Reset Fault" (Bit 3)
 M: Controlwort "Device mode active enable" (Bit 2)
 H: Controlwort "Hold enable" (Bit 1)
 D: Controlwort "Disable" (Bit 0)

4.3 Program Control

The SD6 through the fieldbus can be set to the following operating modes; in doing so, one differentiates between the Control mode and the Device mode:

Control mode	Description
Local operating mode	The SD6 is operated through the local possibilities such as e.g. the digital inputs and outputs or PASO.
Spool position control open loop vpsc (1)	A proportional spool valve is driven with a set-point value, the set-point value is proportional to the valve opening. The spool position is not recorded and controlled (open loop). This control mode is only selectable with SD6 amplifier.
Pressure control valve open loop vprc (3)	A proportional pressure control valve is driven with a set-point value; the set-point value is proportional to the valve pressure. The pressure is not measured and controlled with a pressure sensor (open loop). This control mode is selectable with SD6 amplifier a. SD6 controller.
Pressure control valve closed loop vprc (4)	A proportional pressure control valve is driven with a set-point value; the set-point value is proportional to the valve pressure. The pressure is measured and controlled with a pressure sensor (closed loop). This control mode is only selectable with SD6 controller.
Open loop movement dcol (6)	A proportional spool valve is driven with a set-point value; the set-point value is proportional to the position of the axis. The Position is not measured and controlled with a position sensor (open loop). This control mode is only selectable with SD6 controller.
Velocity control axis dsc (7)	A proportional flow valve is driven with a set-point value; the set-point value is proportional to the valve flow. The flow is measured and controlled with a flow sensor (closed loop). This control mode is only selectable with SD6 controller.
Position control axis dpc (9)	A proportional spool valve is driven with a set-point value; the set-point value is proportional to the position of the axis. The position is measured and controlled with a position sensor (closed loop). This control mode is only selectable with SD6 controller.
Pressure control valve closed loop 2-solenoids vprc (-5)	Wandfluh - specific The same as "Pressure control valve closed loop vprc (4)", but for a control with 2 solenoids. This control mode is only selectable with SD6 controller.
pQ-Control 2-solenoids (-9)	Wandfluh - specific With the Q command value, the cylinder can move in open loop in both directions. The p command value defines the maximum permissible pressure. If this pressure is exceeded the controller reduces the output signal to the valve This control mode is only selectable with SD6 controller.
Alternating control 2-solenoids (-10)	Wandfluh - specific With the position command value, the cylinder can be moved in closed loop in both directions. The p command value defines the maximum permissible pressure. If this pressure is exceeded, the position controller is switched off and the controller reduces the output signal to the valve, This control mode is only selectable with SD6 controller.

The DP-Slave controller card can be set through the parameter "db_DeviceMode" in the following device modes:

Device mode	Description
Command value setting through the bus	The set-point-value setting for the DP-Slave takes place through the fieldbus. This corresponds to the standard device mode.
Command value setting locally	The set-point value setting for the DP-slave takes place locally. This device mode is only possible for certain types of SD6.

The SD6 can be parameterized through the Profibus; correspondingly parameter objects are available for this purpose. Depending on the Device control mode only the appropriate objects (parameters) are accessible.

4.3.1 Specialmode

The DP-Slave controller card can be set through the parameter „dp_Specialmode“ into the following modes: (closed loop mode only).

Spezialmodus	Beschreibung
Deactivated (0)	Normal operation
Profile position control (-1)	In this mode, the motion profiles are set, started and stopped via the fieldbus. Acceleration, deceleration and speed are also set via the fieldbus. To use this mode, Telegram 101 or 103 must be selected.
Manual control (-2)	In this mode, the axis will move with a fixed speed either in positiv or negativ direction.

4.3.1.1 Profile position control

In this mode, apart from the set position also the speed is transmitted to the DP-Slave axis controller. On the basis of this value and the predefined acceleration and deceleration, the DP-Slave axis controller then calculates the corresponding movement profile.

The movement profile predefinition from the PROFIBUS-Master to the DP-Slave axis controller takes place through a defined sequence (handshaking). This sequence is described in more detail in the following.

Travelling to individual positions:

After the axis has reached the target position, the DP-Slave axis controller signal this with the "Target position reached" bit in the status word. Only after a renewed predefinition of a new target position value does the axis continue to move.

The position data are controlled, resp. predefined by the timing (resp., handshaking) of the bits "New_setpoint" in the control word and "Setpoint_acknowledge" in the status word. The bit "New_setpoint" is flank-triggered.

These bits enable a "Request – response" mechanism, in order to make ready, resp., transmit a new position value while the axis controller is already travelling to a position. This minimizes the reaction time of a superimposed control system.

Sequence of a position predefinition from a master:

First the movement data (target position, speed, acceleration, deceleration) have to be transmitted. This is signalled to the DP-Slave axis controller by the master with the change of the bit "New_setpoint" to "1". The DP-Slave axis controller responds with "Setpoint_acknowledge" to "1", as soon as it has internally passed on

the movement data to the profile generator. The master control system now can take the bit "New_setpoint" back to "0", in order that the DP-Slave axis controller can set its "Setpoint_acknowledge" bit back to "0", so that in this manner it signals its readiness to receive new movement data.

Remark: The axis controller therefore can only accept movement data, when the "Setpoint_acknowledge" bit is at "0".

The described mechanism leads to the consequence, that a target position is always reached with the final speed zero and that only after this a new position can be travelled to. If the transmitted movement data are to be taken over immediately (i.e., the data of the movement in progress are overwritten), then the bit "Force_setpoint" in the control word has to be set to "1".

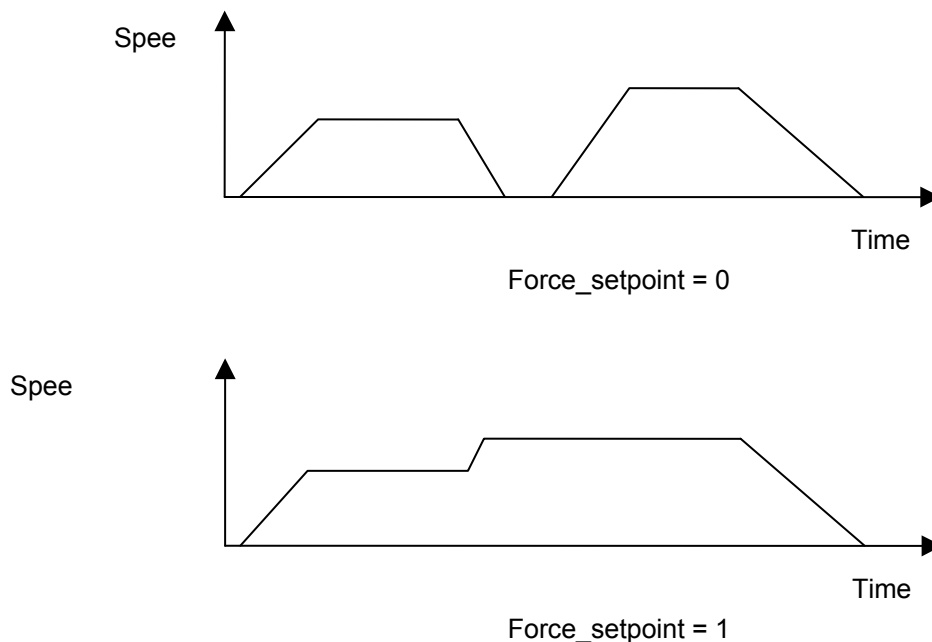

4.3.1.2 Manual control

In this function, the axis moves with a predefined speed in positive (forwards) or negative (reverse) direction. A monitoring of the acceleration, speed and deceleration takes place. Therefore measuring systems have to be connected and the controller parameters of the DP-Slave axis controller have to be correspondingly set. The driving takes place through the corresponding control values.

4.4 Cyclical process data exchange (PZD)

The data exchange is made with consistence about the whole length of the input- and output data. The transmission correspond to the little endian format (refer to section "Data exchange" page 6).

4.4.1 Telegram types

The following telegram types are available on the DP-Slave controller card. They are shared into:

- Data exchange **with** parameter channel
with 4 words for parameters and 3 words for data exchange → telegram type 1
- Data exchange **without** parameter channel
with 3 words for data exchange → telegram type 2
- Data exchange **with** parameter channel
with 4 words for parameters and 2 words for data exchange → telegram type 3
- Data exchange **without** parameter channel
with 2 words for data exchange → telegram type 4
- Data exchange **without** parameter channel
with 7 words for „Profile position control“ → telegram type 101
- Data exchange **with** parameter channel
with with 4 words for parameters and 7 words
for „Profile position control“ → telegram type 103
- Data exchange **with** parameter channel
with 4 words for parameters and 3 words for data exchange → telegram type 113 (optional)
- Data exchange **without** parameter channel
with 3 words for data exchange → telegram type 114 (optional)
- Data exchange **without** parameter channel
with 4 words for data exchange → telegram type 121
- Data exchange **with** parameter channel
with 4 words for parameters and 4 words for data exchange → telegram type 122

	Control Mode							
	1 (Spool position control open loop)	3 (pressure/ flow control open loop)	4, -5 (pressure/ flow control closed loop)	6 (Open loop movement)	7 (Velocity control axis)	9 (Position control axis)	-9 (pQ-control)	-10 (alternating control)
Telegram type	3 / 4	3 / 4	3 / 4 / 101 / 103	1 / 2	1 / 2 / 101 / 103	1 / 2 / 101 / 103	121 / 122	121 / 122
Profibus- Amplifier	selectable		not selectable					
Profibus- Controller	not selectable	selectable						

For the Control Mode "Pressure control valve closed loop 2-solenoids vprc (-5)" the data are valid as for the Control Mode "Pressure control valve closed loop vprc (4)".

Standard telegram 1

The telegram type 1 is defined by the "PROFIBUS Profile Fluid Power Technology" (standard telegram) and is used for the SD6 Electronics in control mode 6 (Open loop movement), 7 (Velocity control axis) and 9 (Position control axis).

	Word 0	Word 1		Word 2	Word 3
Parameter (PKW)	PKE	Res	IND	PWE	

	Word 4	Word 5	Word 6
PZD receive data	Control Word	Command value	

	Word 4	Word 5	Word 6
PZD transmit data	Status Word	Feedback value	

Standard telegram 2

The telegram type 2 is defined by the "PROFIBUS Profile Fluid Power Technology" (standard telegram) and is used for the SD6 Elektronik in control mode 6 (Open loop movement), 7 (Velocity control axis) and 9 (Position control axis).

	word 0	word 1	word 2
PZD receive data	Control Word	Command value	

	word 0	word 1	word 2
PZD transmit data	Status Word	Feedback value	

Standard telegram 3

The telegram type 3 is defined by the "PROFIBUS Profile Fluid Power Technology" (standard telegram) and is used for the SD6 Electronics in control mode 1 (Spool position control open loop), 3 (Pressure control valve open loop) and 4 (Pressure control valve closed loop).

	word 0	word 1		word 2	word 3
Parameter (PKW)	PKE	Res	IND	PWE	

	word 4	word 5
PZD receive data	Control Word	Command value

	word 4	word 5
PZD transmit data	Status Word	Feedback value

Standard telegram 4

The telegram type 4 is defined by the "PROFIBUS Profile Fluid Power Technology" (standard telegram) and is used for the SD6 Electronics in control mode 1 (Spool position control open loop), 3 (Pressure control valve open loop) and 4 (Pressure control valve closed loop).

	word 0	word 1
PZD receive data	Control Word	Command value

	word 0	word 1
PZD transmit data	Status Word	Feedback value

Device Telegram 101

The telegram type 103 is defined by WANDFLUH (user defined telegram) and is used by „Profile position control“ in Control Mode 4, 7 and 9 (closed loop).

	Word 0	Word 1	Word 2
PZD receive data	Control Word	Command value	

	Word 3	Word 4	Word 5	Word 6
PZD receive data	Velocity		Acceleration	Deceleration

	Word 0	Word 1	Word 2
PZD transmit data	Status Word	Feedback value	

Device Telegram 103

The telegram type 103 is defined by WANDFLUH (user defined telegram) and is used by „Profile position control“ in Control Mode 4, 7 and 9 (closed loop).

	Word 0	Word 1	Word 2	Word 3
Parameter (PKW)	PKE	Res	IND	PWE

	Word 4	Word 5	Word 6
PZD receive data	Control Word	Command value	

	Word 7	Word 8	Word 9	Word 10
PZD receive data	Velocity		Acceleration	Deceleration

	Word 4	Word 5	Word 6
PZD transmit data	Status Word	Feedback value	

Device Telegram 113 (optional)

The telegram type 103 is defined by WANDFLUH (user defined telegram) and should be selected for operation mode „Command unipolar (2-solenoids single)“.

	Word 0	Word 1	Word 2	Word 3
Parameter (PKW)	PKE	Res	IND	PWE

	Word 4	Word 5	Word 6
PZD receive data	Control Word	Command value for Solenoid A	Command value for Solenoid B

	Word 4
PZD transmit data	Status Word

Device Telegram 114 (optional)

The telegram type 103 is defined by WANDFLUH (user defined telegram) and should be selected for operation mode „Command unipolar (2-solenoids single)“.

	Word 0	Word 1	Word 2
PZD receive data	Control Word	Command value for Solenoid A	Command value for Solenoid B

	Word 0
PZD transmit data	Status Word

Device Telegram 121

The telegram type 121 is defined by WANDFLUH (user defined telegram) and should be selected for the control mode -9 (pQ-control) and -10 (alternating control).

	Word 0	Word 1	Word 2	Word 3
Parameter (PKW)	PKE	Res	IND	PWE

	Word 4	Word 5	Word 6	Word 7
PZD receive data	Control Word	Pos command value		p command value

	Word 4	Word 5	Word 6	Word 7
PZD transmit data	Status Word	Pos feedback value		p feedback value

Device Telegram 122

The telegram type 122 is defined by WANDFLUH (user defined telegram) and should be selected for the control mode -9 (pQ-control) and -10 (alternating control).

	Word 0	Word 1	Word 2	Word 3
PZD receive data	Control Word	Pos command value		p command value

	Word 0	Word 1	Word 2	Word 3
PZD transmit data	Status Word	Pos feedback value		p feedback value

4.4.2 Receive data (Master → Slave, command values)

Parameter	Length (word)	Signal number	Page
Contro word	1	001	40
Command value	Telegram type 1 / 2: 2 Telegram type 3 / 4: 1 Telegram type 101 / 103: 2	004	45
Command value A / B	Telegram type 113 / 114: 1	004 / 005	45 / 46
Pos command value	Telegram type 121 / 122 2	004	
ü command value	Telegram t ype 121 / 122 1	005	

4.4.3 Transmit data (Slave → Master, feedback values)

Parameter	Length (word)	Signal number	Page
Status Word	1	002	41
Feedback value	Telegram type 1 / 2: 2 Telegram 101 / 103 1	003	77
Pos feedback value	Telegram 121 / 122 2	003	
p feedback value	Telegram 121 / 122 2	123	

4.5 Cyclical parameter data exchange (PKW)

The parameter data exchange is made via the PKW (parameter channel). With the PKW, parameter can be written (Master → Slave) or read (Slave → Master) through the Fieldbus. Exactly one parameter can be written resp. read in one telegram.

The below table shows the structure of the PKW:

PKW							
word 0		word 1		word 2		word 2	
byte 0	byte 1	byte 2	byte 3	byte 4	byte 5	byte 6	byte 7
PKE		Res	IND	PWE			

PKE: parameter signature value

IND: block number

Res: reserved

PWE: parameter value

The instructions and responses are coded in the parameter signature word PKE:

PKE															
bit 15	bit 14	bit 13	bit 12	bit 11	bit 10	bit 9	bit 8	bit 7	bit 6	bit 5	bit 4	bit 3	bit 2	bit 1	bit 0
AK				Res				PNU							

AK: instruction / response signature

Res: reserved

PNU: parameter number

The below table shows the possible instruction / response signatures:

AK			
instruction signature	function	response signature	
		positive	negative
0	no instruction	0	
1	parameter value read	1, 2, 11	7
2	parameter value write (word)	1	7
3	parameter value write (double word)	2	7
4 - 9	reserved		
10	parameter value write (byte)	11	7

In case an instruction can not be processed, the slave responses with a negative response signature (negative = error code), in normal case with a positive response signature.

The parameter value is located to the PWE in the following bytes::

- with parameter length 'word' (instruction signature = 2): byte 6 and byte 7
- with parameter length 'double word' (instruction signature = 3): byte 4, byte 5, byte 6 and byte 7
- with parameter length 'byte' (instruction signature = 10) byte 7

In case the slave responds with an error (response signature = 7), an error message will be located in byte 6 and byte 7 of the PWE. The below table shows the possible error codes:

error code	semantic
0	undefined PNU
1	parameter not changeable
2	lower or upper value range limit overflow
3	undefined IND
5	data type error
18	other errors
201	Invalid parameter
202	The selected parameter can't be read
203	The solenoid choice contained in the value is except range
204	The array index contained in the value is except range
205	The array element cannot be read
206	The array element cannot be described
207	The characteristic optimisation cannot be switched on because of incorrect characteristic values

Remark:

An error message can occur, if a value assignment is not certified in the current control mode or status or in the current mode of operation. Further informations you will find in the associated parameter description.

The below table shows the connection between the data type and parameter length:

data type	parameter length
int8	byte (1 byte)
uint8	byte (1 byte)
int16	word (2 bytes)
uint16	word (2 bytes)
int32	double word (4 bytes)
uint32	double word (4 bytes)
float	double word (4 bytes)
vstring(n)	n bytes

4.5.1 Description of the parameter transmission process

On each request from the Master, the slave will send a response.

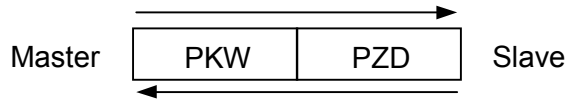

Example 1:

The parameter "Imin A" should be written with the value 450mA.

- data type = uint16 → parameter length = word → AK = 2h
- parameter number = 73 → PNU = 49h
- block number = 3 → IND = 03h
- value = 450 → PWE = 00h 00h 01h c2h

Instruction signature (Master → Slave):

PKW								
word 0			word 1		word 2		word 3	
PKE			Res	IND	PWE			
AK	RES	PNU						
2h	0h	49h	00h	03h	00h	00h	01h	C2h

Response signature (Slave → Master):

PKW								
word 0			word 1		word 2		word 3	
PKE			Res	IND	PWE			
AK	RES	PNU						
1h	0h	49h	00h	03h	00h	00h	01h	C2h

- AK = 1h → 1 = positive response signature for a parameter length = word

Example 2:

The parameter "Dither frequency" should be read.

- data type = uint8 → parameter length = byte → AK = 1h
- parameter number = 98 → PNU = 62h
- block number = 3 → IND = 03h

Instruction signature (Master → Slave):

PKW								
word 0			word 1		word 2		word 3	
PKE			Res	IND	PWE			
AK	RES	PNU						
1h	0h	62h	00h	03h	00h	00h	00h	00h

Response signature (Slave → Master):

PKW								
word 0			word 1		word 2		word 3	
PKE			Res	IND	PWE			
AK	RES	PNU						
Bh	0h	62h	00h	03h	00h	00h	00h	64h

- AK = Bh → 11 = positive response signature for a parameter length = byte
- PWE = 00h 00h 00h 64h → 100 = value of the parameter

4.6 Scaling

By parameter with an unit (e.g. mm, psi, l/min, etc.), the adjusting range and the resolution depends on the control mode and the selected unit. The following table shows the connection:

Control Mode Druckventil mit Drucksensor vprc (4)

Unit:	bar	psi	kN	MPa
Range:	0...500	0...8000	0...1000	0...50
Resolution:	1/1000	1/1000	1/1000	1/1000
Input:	0...500000	0...8000000	0...1000000	0...50000

Control Mode Velocity control axis dsc (7)

Unit:	l/min	mm/s	inch/s	1/min	Grad/s
Range:	0...500	0...2000	0...10000	0...100	0...360
Resolution:	1/1000	1/1000	1/1000	1/1000	1/1000
Input:	0...500000	0...2000000	0...10000000	0...100000	0...360000

Control Mode Position control axis dpc (9)

Unit:	mm	Grad	Inch
Range:	0...2000	0...360	0...100
Resolution:	1/1000	1/1000	1/1000
Input:	0...2000000	0...360000	0...100000

The SD6 has also an internal resolution. This internal resolution determines the adjusting precision for the scaled parameters. The internal resolution depends on the adjusted reference- and interface values. The calculation is as follows:

$$\text{internal resolution} = \text{reference range [unit]} / \text{interface range}$$

$$\begin{aligned} \text{Reference range} &= \text{Max Reference [Einheit]} - \text{Min Reference [Einheit]} \\ \text{Interface range by voltage feedback value} &= (\text{Max Interface [V]} - \text{Min Interface [V]}) \times 1024 / 10 \text{ [V]} \\ \text{Interface range by current feedback value} &= (\text{Max Interface [mA]} - \text{Min Interface [mA]}) \times 1024 / 20 \text{ [mA]} \end{aligned}$$

Example:

Measuring system:	4 ... 20mA	Min. Interface feedback value = 4mA (corresponds 1204Inc at 10Bit-resolution)
		Max. Interface feedback value = 20mA (corresponds 1024Inc at 10Bit-resolution)
Measuring range:	0 ... 300mm	Min. Reference feedback value = 0 mm/1000
		Max. Reference feedback value = 300000 mm/1000

$$\text{Internal resolution} = \frac{300000 \frac{\text{mm}}{1000} - 0 \frac{\text{mm}}{1000}}{1024 \text{Inc} - 204 \text{Inc}} = 365.854 \frac{\text{mm}}{1000 \text{Inc}} = \underline{\underline{0.3659 \frac{\text{mm}}{\text{Inc}}}}$$

The current internal resolution can be read out also through Profibus (refer to section "Internal resolution" page 69).

4.6.1 Internal bus resolution

In the Device Profile in accordance with DSP-408, an internal resolution value is defined. This value is 0 ... 16384. It corresponds to the range of the "Signal type feedback value" (refer to section "Signal type feedback value" page 61).

Examples:

Signal type feedback value = 0 ... 10V:	0 = 0 V
	8192 = 5 V
	16384 = 10 V
Signal type feedback value = 0 ... 20mA	0 = 0 mA
	8192 = 10 mA
	16384 = 20 mA
Signal type feedback value = 4 ... 20mA	3277 = 4 mA
	9831 = 12 mA
	16384 = 20 mA

4.7 Parameter description

In the following section, all parameters, which can be adjusted via PKW (refer to section „Cyclical parameter data exchange (PKW)“ page 27) will be described.

The error code 0 (invalid PNU) can be sent back for different reasons:

- if the current hardware or software execution does not support the parameter
- if the selected control mode (refer to section „Device control mode“ page 42) does not support the parameter
- if the selected mode of operation (refer to section "Mode of operation" page 44) does not support the parameter

The error code 1 (Selected parameter can't be changed) can be sent back for different reasons:

- the parameter can be only read
- the parameter can be only changed, if the SD6 is blocked (status „INIT“ or „DISABLED“, refer to section "State machine" page 16)

ATTENTION: Parameters, which can be transmitted either as PKW or as PZD will become always the value of the PZD transmission. Because of this, it makes no sense to overwrite these parameters with another PKW-value.

Note: A detailed description about the function of each parameter you will find in the corresponding operating instructions of the SD6 Electronics

For the Control Mode "Pressure control valve closed loop 2-solenoids vprc (-5)" the data are valid as for the Control Mode "Pressure control valve closed loop vprc (4)".

4.7.1 Parameter overview

Funktionsparameter:	Control Mode 1 Spool position control open loop		Control Mode 3 Pressure control valve open loop		Control Mode 4 Pressure control valve closed loop		Control Mode 6 Open loop movement		Control Mode 7 Velocity control axis		Control Mode 9 Position control axis		Control Mode -9 pQ-control		Control Mode -10 Alternating control		Detail on page
	PNU	Inde	PNU	Inde	PNU	Inde	PNU	Inde	PNU	Inde	PNU	Inde	PNU	Inde	PNU	Inde	
Parameter																	
Error Code	36	0	36	0	36	0	36	0	36	0	36	0	36	0	36	0	39
Control Word	37	0	37	0	37	0	37	0	37	0	37	0	37	0	37	0	40
Status Word	38	0	38	0	38	0	38	0	38	0	38	0	38	0	38	0	41
Device mode	39	0	39	0	39	0	39	0	39	0	39	0	39	0	39	0	42
Control mode	40	0	40	0	40	0	40	0	40	0	40	0	40	0	40	0	42
Device local	41	0	41	0	41	0	41	0	41	0	41	0	41	0	41	0	42
Capability	50	0	50	0	50	0	50	0	50	0	50	0	50	0	50	0	43
Store Parameter	51	0	51	0	51	0	51	0	51	0	51	0	51	0	51	0	43
Reset Default	52	0	52	0	52	0	52	0	52	0	52	0	52	0	52	0	44
Mode of operation	53	0	53	0	-	-	53	0	-	-	-	-	-	-	-	-	44
Error handling	54	0	54	0	54	0	54	0	54	0	54	0	54	0	54	0	45
Special mode	-	-	-	-	56	0	-	-	56	0	56	0	56	0	56	0	45

Ramps:

Parameter	Control Mode 1 Spool position control open loop		Control Mode 3 Pressure control valve open loop		Control Mode 4 Pressure control valve closed loop		Control Mode 6 Open loop movement		Control Mode 7 Velocity control axis		Control Mode 9 Position control axis		Details auf Seite
	PNU	Index	PNU	Index	PNU	Index	PNU	Index	PNU	Index	PNU	Index	
Ramp type	43	21	43	22	-	-	42	11	-	-	-	-	51
Ramp A up	50	21	50	22	-	-	49	11	-	-	-	-	52
Ramp A down	59	21	59	22	-	-	58	11	-	-	-	-	53
Ramp B up	47	21	47	22	-	-	46	11	-	-	-	-	53
Ramp B down	56	21	56	22	-	-	55	11	-	-	-	-	54
Speed positive	-	-	-	-	62	22	-	-	61	13	61	12	54
Speed negative	-	-	-	-	231	22	-	-	231	13	231	12	55

Analog input preset values:

Parameter	Control Mode 1 Spool position control open loop		Control Mode 3 Pressure control valve open loop		Control Mode 4 Pressure control valve closed loop		Control Mode 6 Open loop movement		Control Mode 7 Velocity control axis		Control Mode 9 Position control axis		Detail on page
	PNU	Index	PNU	Index	PNU	Index	PNU	Index	PNU	Index	PNU	Index	
Signal type feedback val.	-	-	-	-	97	1	-	-	97	1	97	1	61
Used input feedback val.	-	-	-	-	20	1	-	-	20	1	20	1	61
Cablebreak feedback val.	-	-	-	-	96	1	-	-	96	1	96	1	61
Displayed unit	-	-	-	-	84	1	-	-	84	1	84	1	62
Max. Reference (digital)	-	-	-	-	104	1	-	-	104	1	104	1	51
SSI-Resolution	-	-	-	-	41	1	-	-	41	1	41	1	62
SSI-Offset	-	-	-	-	44	1	-	-	44	1	44	1	63
SSI-Bitcount	-	-	-	-	69	1	-	-	69	1	69	1	63
Start/Stop-Typ	-	-	-	-	68	1	-	-	68	1	68	1	63
Start/Stop-C_Value	-	-	-	-	65	1	-	-	65	1	65	1	64
Start/Stop-Offset	-	-	-	-	105	1	-	-	105	1	105	1	64

Solenoid outputs:

Parameter	Control Mode 1 Spool position control open loop		Control Mode 3 Pressure control valve open loop		Control Mode 4 Pressure control valve closed		Control Mode 6 Open loop movement		Control Mode 7 Velocity control axis		Control Mode 9 Position control axis		Detail on page
	PNU	Index	PNU	Index	PNU	Index	PNU	Index	PNU	Index	PNU	Index	
Imin A	107	21	107	22	107	22	73	3	73	3	73	3	47
Imax A	251	21	251	22	251	22	129	3	129	3	129	3	47
Imin B	110	21	110	22	110	22	76	3	76	3	76	3	48
Imax B	252	21	252	22	252	22	130	3	130	3	130	3	48
Deadband compensation type	106	21	106	22	-	-	100	11	-	-	-	-	55
Deadband threshold A	113	21	113	22	-	-	101	11	-	-	-	-	56
Deadband threshold B	254	21	254	22	-	-	-	-	-	-	-	-	56
Dither type	187	21	187	22	187	22	97	3	97	3	97	3	57
Dither Frequency	191	21	191	22	191	22	98	3	98	3	98	3	57
Dither Amplitude	188	21	188	22	188	22	101	3	101	3	101	3	58

Scaling feedback value:

Parameter	Control Mode 1 Spool position control open loop		Control Mode 3 Pressure control valve open loop		Control Mode 4 Pressure control valve closed		Control Mode 6 Open loop movement		Control Mode 7 Velocity control axis		Control Mode 9 Position control axis		Detail on page
	PNU	Index	PNU	Index	PNU	Index	PNU	Index	PNU	Index	PNU	Index	
Min Reference	-	-	-	-	23	1	-	-	102	1	50	1	50
Max Reference	-	-	-	-	26	1	-	-	103	1	53	1	50
Min Interface	-	-	-	-	35	1	-	-	100	1	59	1	49
Max Interface	-	-	-	-	38	1	-	-	101	1	62	1	49

General controller parameter:

Parameter	Control Mode 1 Spool position control open loop		Control Mode 3 Pressure control valve open loop		Control Mode 4 Pressure control valve closed		Control Mode 6 Open loop movement		Control Mode 7 Velocity control axis		Control Mode 9 Position control axis		Detail on page
	PNU	Index	PNU	Index	PNU	Index	PNU	Index	PNU	Index	PNU	Index	
System control	-	-	-	-	131	3	-	-	131	3	131	3	58
Output solenoid A	-	-	-	-	132	3	-	-	132	3	132	3	59
Output solenoid B	-	-	-	-	133	3	-	-	133	3	133	3	59
Inin always active	-	-	-	-	134	3	-	-	134	3	134	3	60
Solenoid 'In Position'	-	-	-	-	250	22	-	-	250	13	250	12	60

Controller specific windows parameter:

Parameter	Control Mode 1 Spool position control open loop		Control Mode 3 Pressure control valve open loop		Control Mode 4 Pressure control valve closed		Control Mode 6 Open loop movement		Control Mode 7 Velocity control axis		Control Mode 9 Position control axis		Detail on page
	PNU	Index	PNU	Index	PNU	Index	PNU	Index	PNU	Index	PNU	Index	
Target window type	-	-	-	-	203	22	-	-	149	13	177	12	65
Target window threshold	-	-	-	-	204	22	-	-	150	13	178	12	65
Target window delay time	-	-	-	-	232	22	-	-	232	13	232	12	67
Trailing window type	-	-	-	-	150	22	-	-	112	13	140	12	66
Trailing window threshold	-	-	-	-	160	22	-	-	122	13	150	12	67
Trailing window delay time	-	-	-	-	157	22	-	-	119	13	147	12	67
Solenoid off window threshold	-	-	-	-	233	22	-	-	233	13	233	12	68
Solenoid off window delay time	-	-	-	-	234	22	-	-	234	13	234	12	68
Internal resolution	-	-	-	-	254	22	-	-	254	13	254	12	69

Controller parameter:

Parameter	Control Mode 1 Spool position control open loop		Control Mode 3 Pressure control valve open loop		Control Mode 4 Pressure control valve closed loop		Control Mode 6 Open loop movement		Control Mode 7 Velocity control axis		Control Mode 9 Position control axis		Detail on page
	PNU	Index	PNU	Index	PNU	Index	PNU	Index	PNU	Index	PNU	Index	
Command Feed forward	-	-	-	-	236	22	-	-	236	13	236	12	69
Velocity Feed forward	-	-	-	-	237	22	-	-	237	13	237	12	70
I-part outside I-window	-	-	-	-	235	22	-	-	235	13	235	12	70
P-amplification positive	-	-	-	-	238	22	-	-	106	13	106	12	71
P-amplification negative	-	-	-	-	239	22	-	-	239	13	239	12	71
Integrator type	-	-	-	-	-	-	-	-	-	-	115	12	72
I-time positive	-	-	-	-	240	22	-	-	109	13	116	12	72
I-time negative	-	-	-	-	241	22	-	-	241	13	241	12	73
I-window outside positive	-	-	-	-	242	22	-	-	242	13	119	12	73
I-window outside negative	-	-	-	-	243	22	-	-	243	13	243	12	74
I-window inside positive	-	-	-	-	248	22	-	-	248	13	248	12	74
I-window inside negative	-	-	-	-	249	22	-	-	249	13	249	12	75
D-time positive	-	-	-	-	244	22	-	-	244	13	244	12	75
D-time negative	-	-	-	-	245	22	-	-	245	13	245	12	76
D-amplification positive	-	-	-	-	246	22	-	-	246	13	246	12	76
D-amplification negative	-	-	-	-	247	22	-	-	247	13	247	12	77

Signals:

Parameter	Control Mode 1 Spool position control open loop		Control Mode 3 Pressure control valve open loop		Control Mode 4 Pressure control valve closed loop		Control Mode 6 Open loop movement		Control Mode 7 Velocity control axis		Control Mode 9 Position control axis		Control Mode -9 pQ-control		Control Mode -10 Alternating control		Detail on page
	PNU	Inde	PNU	Inde	PNU	Inde	PNU	Inde	PNU	Inde	PNU	Inde	PNU	Inde	PNU	Inde	
Command value	21	21	21	22	21	22	21	11	21	13	21	12	21	21	21	65	45
Command B / pressure	253	21	253	22	-	-	-	-	-	-	-	-	253	65	253	65	46
Feedback value	-	-	-	-	144	22	-	-	100	13	100	12	-	-	100	65	77
Feedback pressure	-	-	-	-	-	-	-	-	-	-	-	-	144	65	144	65	78
Control deviation	-	-	-	-	147	22	-	-	103	13	103	12	-	-	103	65	78
Control dev. pressure	-	-	-	-	-	-	-	-	-	-	-	-	147	65	147	65	79

Characteristic optimisation:

Parameter	Control Mode 1 Spool position control open loop		Control Mode 3 Pressure control valve open loop		Control Mode 4 Pressure control valve closed loop		Control Mode 6 Open loop movement		Control Mode 7 Velocity control axis		Control Mode 9 Position control axis		Detail on page
	PNU	Index	PNU	Index	PNU	Index	PNU	Index	PNU	Index	PNU	Index	
Characteristic optimisation	20	64	20	64	20	64	20	64	20	64	20	64	80
X-axis	21	64	21	64	21	64	21	64	21	64	21	64	80
Y-axis	22	64	22	64	22	64	22	64	22	64	22	64	82
Base	23	64	23	64	23	64	23	64	23	64	23	64	83
Solenoid choice	24	64	24	64	24	64	24	64	24	64	24	64	83

4.7.2 Error Code

Parameter description

Description	Error code
IND	0
PNU	36
PZD-number	--
Parameter name	db_ErrorCode
Data type	uint16
Parameter length (byte)	2
Access	r

Value description

Code (Hex)	Name	Description	Reaction
0000	No error	No error is present	
1000	General error	A general error is present	FAULT
2300	Current device output	Short circuit on a solenoid output	FAULT
3412	Power supply voltage too low	The supply voltage is too low	FAULT
5231	Transducer sensor 1	The feedback value (analog signal) voltage is too low or there occurred a cable break	FAULT
5510	EPROM / EEPROM	Device parameter can not be stored or read in or from the non-volatile memory	FAULT
8100	Communication	Bus communication is interrupted	FAULT

4.7.3 Control Word

Parameter description

Description	Control the device
IND	0
PNU	37
PZD-number	001
Parameter name	db_ControlWord
Data type	uint16
Parameter length (byte)	2
Access	r/w

Value description

The control word is bit coded, i.e., each individual bit has a certain control function. The table below lists the individual functions with the bit belonging to it.

MSB								LSB							
Bit	Bit	Bit	Bit	Bit	Bit	Bit	Bit	Bit	Bit	Bit	Bit	Bit	Bit	Bit	Bit
15	14	13	12	11	10	9	8	7	6	5	4	3	2	1	0
High - Byte								Low - Byte							

Bit	Name	description	
0	Disable (D)	Set the DP-Slave controller card in the state "DISABLED"	
1	Hold enable (H)	Set the DP-Slave controller card in the state "HOLD"	
2	Device mode active (M)	Set the DP-Slave controller card in the state "DEVICE_MODE_ACTIVE"	
3	Reset fault (R)	Reset an error	
4	Reserved		
5	Reserved		
6	Reserved		
7	Reserved		
8	Reserved		
9	Positive	Special mode -2	Moves the axis forward
10	Force_setpoint	Special mode -1	The transmitted motion profile values will be take over immediately
	Negative	Special mode -2	Moves the axis backward
10	Reserved		
11	Reserved		
12	Reserved		
13	Release Solenoid A	operating mode 3	Releases the solenoid output A
	New_setpoint	Special mode -1	Send new motion profile values to the DP-Slave controller
	Fast speed	Special mode -2	The fast speed will be active
14	Release Solenoid B	operating mode 3	Releases the solenoid output B
15	Manufacturer-specific		

4.7.4 Status Word

Parameter description

Description	State of the device
IND	0
PNU	38
PZD-number	002
Parameter name	db_StatusWord
Data type	uint16
Parameter length (byte)	2
Access	r

Value description

The control word is bit coded, i.e., each individual bit has a certain control function. The table below lists the individual functions with the bit belonging to it.

MSB								LSB							
Bit 15	Bit 14	Bit 13	Bit 12	Bit 11	Bit 10	Bit 9	Bit 8	Bit 7	Bit 6	Bit 5	Bit 4	Bit 3	Bit 2	Bit 1	Bit 0
High - Byte								Low - Byte							

Bit	Parameter name	Description
0	Disable (D)	Set the DP-Slave controller card in the state "DISABLED".
1	Hold enable (H)	Set the DP-Slave controller card in the state "HOLD"
2	Device mode active (M)	Set the DP-Slave controller card in the state "DEVICE_MODE_ACTIVE".
3	Reset fault (R)	Reset an error
4	Local control	Is active, if the SD6 is operated locally
5	Warning	
6		
7		
8		
9	Ramp running	The preset value ramp is active (only in device mode 1 and 3)
10		
11		
12	Window reached	Device mode 4, 7 and 9 The target window is reached
		Device mode -10 The Position target window is reached
13	Solenoid output A released	Operating mode 3 Solenoid output A is released (available only in Operation mode 3, see "Mode of operation" page 44).
	Setpoint_acknowdege	Special mode -1 New motion profiles values are take over from the DP-Slave controller
	Pressure window reached	Device mode -9 and -10 The Pressure target window is reached
14	Solenoid output B released	Operating mode 3 Solenoid output B is released (available only in Operation mode 3, see "Mode of operation" page 44).
	Pressure controller active	Device mode -9 and -10 The pressure controller is active
15	Manufacturer-specific	

4.7.5 Device mode

Parameter description

Description	Set the device mode
IND	0
PNU	39
PZD-number	-
Parameter name	db_DeviceMode
Data type	int8
Parameter length (byte)	1
Access	r/w

Value description

1	Preset value via bus
2	Preset value locally

4.7.6 Device control mode

Parameter description

Description	Control Mode
IND	0
PNU	40
PZD-number	-
Parameter name	db_ControlMode
Data type	Int8
Parameter length (byte)	1
Access	r/w

Value description

1	Spool position control open loop	telegram type 3 or 4
3	Pressure control valve open loop	telegram type 3 or 4
4	Pressure control valve closed	telegram type 3 or 4
6	Open loop movement	telegram type 1 or 2
7	Velocity control axis	telegram type 1 or 2
9	Position control axis	telegram type 1 or 2
-5	Pressure control closed loop 2 solenoids	telegram type 1 or 2
-9	pQ-control	telegram type 121 or 122
-10	Alternating control	telegram type 121 or 122

Remark:

With the SD6 amplifier the control mode 1 and 3 are selectable. With the SD6 controller the control mode 3, 4, 6, 7, 9, -5, -9 and -10 are selectable. Depending upon control mode, the master must support another SD6 telegram (refer to section "Available telegrams" page 7). The telegram selection can be made only via PASO. To do this, the SD6 electronics must be separate from the Profibus.

4.7.7 Device local

Parameter description

Description	Specifies the source for the control word
IND	0
PNU	41
PZD-number	-
Parameter name	db_Local
Data type	int8

Parameter length (byte)	1
Access	r/w

Value description

1	Control word acting is made via bus
2	Control word acting is made locally

4.7.8 Capability

Parameter description

Description	Device capability
IND	0
PNU	50
PZD-number	-
Parameter name	db_Capability
Data type	uint32
Parameter length (byte)	4
Access	r

Value description

0x1B 0x17 0x80 0x00	Default value: depending on the valve [Read only] Value 0 = disabled / not supported Value 1 = enabled / supported Bit 0 – 15 = Specific information (manufacturer-specific 8000h-FFFFh) Bit 16 – 23 = Drive information (not used) Bit 24 = Hydraulic proportional valve Bit 25 = Spool position control open loop (without LVDT) Bit 26 = Spool position control closed loop (with LVDT) Bit 27 = Pressure control valve open loop (without feedback sensor) Bit 28 = Pressure control valve closed loop (with feedback sensor) Bit 29 = P/Q Valve Bit 30 = Reserved Bit 31 = Modular device (can have various functions)
---------------------	---

4.7.9 Store Parameter

Parameter description

Description	Specifies the source for the control word
IND	0
PNU	51
PZD-number	-
Parameter name	db_StoreParameter
Data type	Int32
Parameter length (byte)	4
Access	w

Value description

0	Do nothing
0x73 0x61 0x76 0x65 (= 's' 'a' 'v' 'e')	Store all parameters into the non-volatile memory

4.7.10 Reset Default

Parameter description

Description	All device parameters will be set to default values
IND	0
PNU	52
PZD-number	-
Parameter name	db_ResetDefault
Data type	Int32
Parameter length (byte)	4
Access	w

Value description

0	
0x6C 0x6F 0x61 0x64 (= 'l' 'o' 'a' 'd')	

4.7.11 Mode of operation

Parameter description

Description	Operation mode. Refer to section „Operating mode“ page 14.
IND	0
PNU	Control Mode 1, 2, 6: 53 Control Mode 4, 7, 9: -
PZD-number	-
Parameter name	db_Operation_Mode
Data type	Int8
Parameter length (byte)	1
Access	r/w

Value description

0	Command unipolar (1-solenoid)
1	Command unipolar (2-solenoids)
2	Command bipolar (2-solenoids)
3	Command unipolar (2-solenoids single, optional) Remark: With this mode of operation each solenoid must be released individually over the control Word (refer to section "Control Word" page 40)

4.7.12 Error handling

Parameter description

Description	Error handling (= 'Error handling' in PASO)
IND	0
PNU	54
PZD-number	-
Parameter name	db_Error_Handling
Data type	Int8
Parameter length (byte)	1
Access	r/w

Value description

0	In case of an error, switch solenoid A+B off
1	In case of an error, switch solenoid A on
2	In case of an error, switch solenoid B on
3	In case of an error, switch solenoid A+B on

4.7.13 Special mode

Parameter Beschreibung

Beschreibung	Selection of „Profile position control“ or „Manual control“. For a detailed description of these modes refer to „Specialmode“ page 20.
IND	0
PNU	56
PZD-Nummer	-
Name	db_Specialmode
Datentyp	int8
Parameterlänge (Byte)	1
Access	r/w

Wert Beschreibung

0	Normal-Mode
-1	Profile position control
-2	Manual control

4.7.14 Command value

Description	Command value (Control mode 1, 3, 4, -5, 6, 7, 9) Command value position (Control mode -9 and -10)
IND	Control Mode 1: 21 Control Mode 3, 4, -5: 22 Control Mode 6: 11 Control Mode 7: 13 Control Mode 9: 12 Control Mode -9, -10: 65
PNU	21
PZD-number	004
Parameter name	Control Mode 1: vpoc_Setpoint_AVal Control Mode 3: vprc_Setpoint_AVal Control Mode 4, -5: vprc_Setpoint_Val Control Mode 6: dcol_Setpoint_AVal Control Mode 7: dsp_Setpoint_Val Control Mode 9: dpc_Setpoint_Val Control Mode -9, -10: pq_SetpointPos
Data type	Control Mode 1, 3, 4, -5: uint16

	Control Mode 6, 7, 9, -9, -10: uint 32
Parameter length (byte)	Control Mode 1, 3, 4, -5: 2 Control Mode 6, 7, 9, -9, -10: 4
Access	r/w

Value description

Range	Control Mode 1, 3 (telegram type 3 and 4): -16384...16384 (refer to section "Internal bus resolution" page 31) Control Mode 4, -5 (telegram type 3 and 4): 0...16384 (refer to section "Internal bus resolution" page 31) Control Mode 6, -9 (telegram type 1, 2, 121, 122): -100000...+100000 = ±100% Control Mode 7, 9, -10 (telegram type 1, 2, 121, 122): 0...maxReference (refer to section "Max. Reference transducer" page 50)
Unit	Control Mode 1, 3 (telegram type 3 and 4): Inc Control Mode 4, -5 (telegram type 3 and 4): Inc Control Mode 6, -9 (telegram type 1, 2, 121, 122): % Control Mode 7, 9, -9, -10 (telegram type 1, 2, 121, 122): selected unit
Default Value	-
Step	Control Mode 1, 3 (telegram type 3 and 4): 16 = 0.098% Control Mode 4, -5 (telegram type 3 and 4): 16 = actual step Control Mode 6, -9 (telegram type 1, 2, 121, 122): 98 = 0.098%% Control Mode 7, 9, -10 (telegram type 1, 2, 121, 122): actual step

4.7.15 Command value B

Description	Command value B (Control mode 1, 3, 6 only used in the mode of operation "Command unipolar (2-sol single)". Command value pressure: (Control mode -9, -10)
IND	Control Mode 1: 21 Control Mode 3: 22 Control Mode 4, -5, 6, 7, 9: - Control Mode -9, -10: 65
PNU	Control Mode 1, 3, -9, -10: 253 Control Mode 4, -5, 6, 7, 9: -
PZD-number	005
Parameter name	Control Mode 1: vpoc_Setpoint_BVal Control Mode 3: vprc_Setpoint_BVal Control Mode -9, -10: pq_SetpointPres
Data type	Control Mode 1, 3, -9, -10 (telegram type 3, 4, 113, 114, 121, 122): uint16
Parameter length (byte)	Control Mode 1, 3, -9, -10 (telegram type 3, 4, 113, 114, 121, 122): 2
Access	r/w

Value description

Range	Control Mode 1, 3, -9, -10 (telegram type 3, 4, 113, 114, 121, 122): 0...16384 (refer to section "Internal bus resolution" page 31)
Unit	Control Mode 1, 3, -9, -10 (telegram type 3, 4, 113, 114, 121, 122): Inc
Default Value	-
Step	Control Mode 1, 3, -9, -10 (telegram type 3, 4, 113, 114, 121, 122): 16 = 0.098%

4.7.16 Imin A

Parameter description

Description	Minimum current solenoid A (= 'Imin A' in PASO)
IND	Control Mode 1: 21 Control Mode 3, 4: 22 Control Mode 6, 7, 9: 3
PNU	Control Mode 1, 3, 4: 107 Control Mode 6, 7, 9: 73
PZD-number	-
Parameter name	Control Mode 1: vpc_Deadband_AsideVal Control Mode 3: vprc_Deadband_AsideVal Control Mode 4: vprc_Deadband_AsideVal Control Mode 6: dop_drivePos_AsideVal Control Mode 7: dop_drivePos_AsideVal Control Mode 9: dop_drivePos_AsideVal
Data type	Control Mode 1, 3, 4: uint16 Control Mode 6, 7, 9: uint32
Parameter length (byte)	Control Mode 1, 3, 4: 2 Control Mode 6, 7, 9: 4
Access	r/w

Value description

Range	0...16384 (24V version: corresponds 0 ... 1536 mA) (12V version: corresponds 0 ... 2560 mA) Upper limit = adjusted I _{max} A
Unit	mA
Default Value	Valve dependent
Step	16 (corresponds 1.5 mA, 24V version) (corresponds 2.5 mA, 12V version)

4.7.17 Imax A

Parameter description

Description	Maximum current solenoid A (= 'Imax A' in PASO)
IND	Control Mode 1: 21 Control Mode 3, 4: 22 Control Mode 6, 7, 9: 3
PNU	Control Mode 1, 3, 4: 251 Control Mode 6, 7, 9: 129
PZD-number	-
Parameter name	Control Mode 1: vpc_I _{max} _AsideVal Control Mode 3: vprc_I _{max} _AsideMaxVal Control Mode 4: vprc_I _{max} _AsideMaxVal Control Mode 6: dop_drivePos_AsideMaxVal Control Mode 7: dop_drivePos_AsideMaxVal Control Mode 9: dop_drivePos_AsideMaxVal
Data type	Control Mode 1, 3, 4: uint16 Control Mode 6, 7, 9: uint32
Parameter length (byte)	Control Mode 1, 3, 4: 2 Control Mode 6, 7, 9: 4
Access	r/w

Value description

Range	0...16384 (24V version: corresponds 0 ... 1536 mA)
-------	--

	(12V version: corresponds 0 ... 2560 mA) Lower limit = adjusted Imin A Upper limit depends to the valve type
Unit	mA
Default Value	Valve dependent
Step	16 (corresponds 1.5 mA, 24V version) (corresponds 2.5 mA, 12V version)

4.7.18 Imin B

Parameter description

Description	Minimum current solenoid B (= 'Imin B' in PASO), only with 2 solenoids
IND	Control Mode 1: 21 Control Mode 3, 4: 22 Control Mode 6, 7, 9: 3
PNU	Control Mode 1, 3, 4: 110 Control Mode 6, 7, 9: 76
PZD-number	-
Parameter name	Control Mode 1: vpoc_Deadband_BsideVal Control Mode 3: vprc_Deadband_BsideVal Control Mode 4: vprc_Deadband_BsideVal Control Mode 6: dop_drivePos_BsideVal Control Mode 7: dop_drivePos_BsideVal Control Mode 9: dop_drivePos_BsideVal
Data type	Control Mode 1, 3, 4: uint16 Control Mode 6, 7, 9: uint32
Parameter length (byte)	Control Mode 1, 3, 4: 2 Control Mode 6, 7, 9: 4
Access	r/w

Value description

Range	0...16384 (24V version: corresponds 0 ... 1536 mA) (12V version: corresponds 0 ... 2560 mA) Upper limit = adjusted Imax B
Unit	mA
Default Value	Valve dependent
Step	16 (corresponds 1.5 mA, 24V version) (corresponds 2.5 mA, 12V version)

4.7.19 Imax B

Parameter description

Description	Maximum current solenoid B (= 'Imax B' in PASO), only with 2 solenoids
IND	Control Mode 1: 21 Control Mode 3, 4: 22 Control Mode 6, 7, 9: 3
PNU	Control Mode 1, 3, 4: 252 Control Mode 6, 7, 9: 130
PZD-number	-
Parameter name	Control Mode 1: vpoc_Imax_BsideVal Control Mode 3: vprc_Imax_BsideMaxVal Control Mode 4: vprc_Imax_BsideMaxVal Control Mode 6: dop_drivePos_BsideMaxVal Control Mode 7: dop_drivePos_BsideMaxVal Control Mode 9: dop_drivePos_BsideMaxVal
Data type	Control Mode 1, 3, 4: uint16

	Control Mode 6, 7, 9: uint32
Parameter length (byte)	Control Mode 1, 3, 4: 2 Control Mode 6, 7, 9: 4
Access	r/w

Value description

Range	0...16384 (24V version: corresponds 0 ... 1536 mA) (12V version: corresponds 0 ... 2560 mA) Lower limit = adjusted I _{min} B Upper limit depends to the valve type
Unit	mA
Default Value	Valve dependent
Step	16 (corresponds 1.5 mA, 24V version) (corresponds 2.5 mA, 12V version)

4.7.20 Min. Interface transducer

Parameter description

Description	Min. Interface Istwert (= 'Min. Interface Istwert' in PASO)
IND	Control Mode 1, 3, 6: - Control Mode 4, 7, 9: 1
PNU	Control Mode 1, 3, 6: - Control Mode 4: 35 Control Mode 7: 100 Control Mode 9: 59
PZD-number	-
Parameter name	Control Mode 1, 3, 6: - Control Mode 4, 7, 9: dav_Min_Int_Transducer
Data type	uint16
Parameter length (byte)	2
Access	r/w

Value description

Range	0...10000 = 0...10V by voltage feedback value 0...20000 = 0...20mA by current feedback value
Unit	V resp. mA
Default Value	0
Step	0.001V resp. 0.001mA

4.7.21 Max. Interface transducer

Parameter description

Description	Max. Interface Istwert (= 'Max. Interface Istwert' in PASO)
IND	Control Mode 1, 3, 6: - Control Mode 4, 7, 9: 1
PNU	Control Mode 1, 3, 6: - Control Mode 4: 38 Control Mode 7: 101 Control Mode 9: 62
PZD-number	-
Parameter name	Control Mode 1, 3, 6: - Control Mode 4, 7, 9: dav_Max_Int_Transducer
Data type	uint16
Parameter length (byte)	2
Access	r/w

Value description

Range	0...10000 = 0...10V by voltage feedback value 0...20000 = 0...20mA by voltage feedback value
Unit	1
Default Value	10000 resp. 20000
Step	0.001V resp. 0.001mA

4.7.22 Min. Reference transducer
Parameter description

Description	Min. Reference Istwert (= 'Min. Reference Istwert' in PASO)
IND	Control Mode 1, 3, 6: - Control Mode 4, 7, 9: 1
PNU	Control Mode 1, 3, 6: - Control Mode 4: 23 Control Mode 7: 102 Control Mode 9: 50
PZD-number	-
Parameter name	Control Mode 1, 3, 6: - Control Mode 4, 7, 9: dav_Min_Ref_Transducer
Data type	uint32
Parameter length (byte)	4
Access	r/w

Value description

Range	Dependent on the control mode and unit (refer to section "Scaling" page 30)
Unit	Adjusted unit, refer to section "Displayed unit" page 62.
Default Value	0
Step	1

4.7.23 Max. Reference transducer
Parameter description

Description	Max. Reference Istwert (= 'Max. Reference Istwert' in PASO)
IND	Control Mode 1, 3, 6: - Control Mode 4, 7, 9: 1
PNU	Control Mode 1, 3, 6: - Control Mode 4: 26 Control Mode 7: 103 Control Mode 9: 53
PZD-number	-
Parameter name	Control Mode 1, 3, 6: - Control Mode 4, 7, 9: dav_Max_Ref_Transducer
Data type	uint32
Parameter length (byte)	4
Access	r/w

Value description

Range	Dependent on the control mode and unit (refer to section "Scaling" page 30)
Unit	Adjusted unit, refer to section "Displayed unit" auf page 62.
Default Value	10
Step	1

4.7.24 Max. Reference transducer digital
Parameter Beschreibung

Beschreibung	Max. Reference feedback value (= 'Max. Reference feedback' in PASO) for digital Transducers.
IND	Control Mode 1, 3, 6: - Control Mode 4, 7, 9: 1
PNU	Control Mode 1, 3, 6: - Control Mode 4, 7, 9: 104
PZD-Nummer	-
Name	Control Mode 1, 3, 6: - Control Mode 4, 7, 9: dav_Max_Ref_Dig_Transducer
Datentyp	uint32
Parameterlänge (Byte)	4
Access	r/w

Wert Beschreibung

Bereich	Dependent on the control mode and unit (refer to section "Scaling" page 30)
Einheit	Adjusted unit, refer to section "Displayed unit" auf page 62.
Default Wert	100
Schrittweite	1

4.7.25 Ramp type
Parameter description

Description	Ramp type
IND	Control Mode 1: 21 Control Mode 3: 22 Control Mode 6: 11 Control Mode 4, 7, 9: -
PNU	Control Mode 1, 3: 43 Control Mode 6: 42 Control Mode 4, 7, 9: -
PZD-number	-
Parameter name	Control Mode 1: vpoc_ramp_Type Control Mode 3: vprc_ramp_Type Control Mode 6: dcol_ramp_Type Control Mode 4, 7, 9: -
Data type	int8
Parameter length (byte)	1
Access	r/w

Value description

0	no ramp
3	Linear ramp (2 separate parameters for acceleration positive and negative)

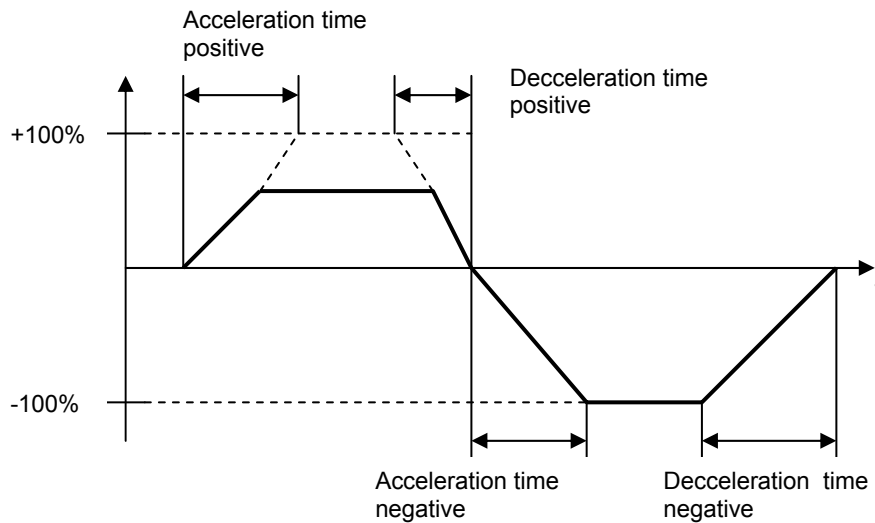
Ramp type 3:

4.7.26 Ramp A up
Parameter description

Description	Start ramp positive (= 'Ramp A up' in PASO)
IND	Control Mode 1: 21 Control Mode 3: 22 Control Mode 6: 11 Control Mode 4, 7, 9: -
PNU	Control Mode 1, 3: 50 Control Mode 6: 49 Control Mode 4, 7, 9: -
PZD-number	-
Parameter name	Control Mode 1: vpoc_ramp_AccTimePosVal Control Mode 3: vprc_ramp_AccTimePosVal Control Mode 4: - Control Mode 6: dcol_ramp_AccTimePosVal Control Mode 7: - Control Mode 9: -
Data type	Control Mode 1, 3: uint16 Control Mode 6: uint32
Parameter length (byte)	Control Mode 1, 3: 2 Control Mode 6: 4
Access	r/w

Value description

Range	0 ... 51000
Unit	ms
Default Value	0
Step	1

4.7.27 Ramp A down

Parameter description

Description	Start ramp A negative (= 'Ramp A down' in PASO)
IND	Control Mode 1: 21 Control Mode 3: 22 Control Mode 6: 11 Control Mode 4, 7, 9: -
PNU	Control Mode 1, 3: 59 Control Mode 6: 58 Control Mode 4, 7, 9: -
PZD-number	-
Parameter name	Control Mode 1: vpoc_ramp_DecTimePosVal Control Mode 3: vprc_ramp_DecTimePosVal Control Mode 6: dcol_ramp_DecTimePosVal Control Mode 4, 7, 9: -
Data type	Control Mode 1, 3: uint16 Control Mode 6: uint32
Parameter length (byte)	Control Mode 1, 3: 2 Control Mode 6: 4
Access	r/w

Value description

Range	0 ... 51000
Unit	ms
Default Value	0
Step	1

4.7.28 Ramp B up

Parameter description

Description	Stop ramp negative (= 'Ramp B up' in PASO) , only with 2 solenoids
IND	Control Mode 1: 21 Control Mode 3: 22 Control Mode 6: 11 Control Mode 4, 7, 9: -
PNU	Control Mode 1, 3: 47 Control Mode 6: 46 Control Mode 4, 7, 9: -
PZD-number	-
Parameter name	Control Mode 1: vpoc_ramp_AccTimeNegVal Control Mode 3: vprc_ramp_AccTimeNegVal Control Mode 6: dcol_ramp_AccTimeNegVal Control Mode 4, 7, 9: -
Data type	Control Mode 1, 3: uint16 Control Mode 6: uint32
Parameter length (byte)	Control Mode 1, 3: 2 Control Mode 6: 4
Access	r/w

Value description

Range	0 ... 51000
Unit	ms
Default Value	0
Step	1

4.7.29 Ramp B down

Parameter description

Description	Stop ramp positive (= 'Ramp B down' in PASO) , only with 2 solenoids
IND	Control Mode 1: 21 Control Mode 3: 22 Control Mode 6: 11 Control Mode 4, 7, 9: -
PNU	Control Mode 1, 3: 56 Control Mode 6: 55 Control Mode 4, 7, 9: -
PZD-number	-
Parameter name	Control Mode 1: vpoc_ramp_DecTimeNegVal Control Mode 3: vprc_ramp_DecTimeNegVal Control Mode 6: dcol_ramp_DecTimeNegVal Control Mode 4, 7, 9: -
Data type	Control Mode 1, 3: uint16 Control Mode 6: uint32
Parameter length (byte)	Control Mode 1, 3: 2 Control Mode 6: 4
Access	r/w

Value description

Range	0 ... 51000
Unit	ms
Default Value	0
Step	1

4.7.30 Speed positive

Parameter description

Description	Speed positive (= 'Speed +' in PASO)
IND	Control Mode 4: 22 Control Mode 7: 13 Control Mode 9: 12 Control Mode 1, 3, 6: -
PNU	Control Mode 4: 62 Control Mode 7, 9: 61 Control Mode 1, 3, 6: -
PZD-number	-
Parameter name	Control Mode 1: - Control Mode 3: - Control Mode 4: vprc_Ramp_Vel Control Mode 6: - Control Mode 7: dsp_Ramp_Vel Control Mode 9: dpc_Ramp_Vel
Data type	uint32
Parameter length (byte)	4
Access	r/w

Value description

Range	Internal step...2000000
Unit	Einheit/s
Default Value	100000
Step	Internal step

4.7.31 Speed negative
Parameter description

Description	Speed negative (= 'Speed -' in PASO)
IND	Control Mode 4: 22 Control Mode 7: 13 Control Mode 9: 12 Control Mode 1, 3, 6: -
PNU	Control Mode 4, 7, 9: 231 Control Mode 1, 3, 6: -
PZD-number	-
Parameter name	Control Mode 1: - Control Mode 3: - Control Mode 4: vprc_Ramp_VelNeg Control Mode 6: - Control Mode 7: dsp_Ramp_VelNeg Control Mode 9: dpc_Ramp_VelNeg
Data type	uint32
Parameter length (byte)	4
Access	r/w

Value description

Range	Internal step...2000000
Unit	Einheit/s
Default Value	100000
Step	Internal step

4.7.32 Deadband compensation type
Parameter description

Description	Deadband compensation type
IND	Control Mode 1: 21 Control Mode 3: 22 Control Mode 6: 11 Control Mode 4, 7, 9: -
PNU	Control Mode 1, 3: 106 Control Mode 6: 100 Control Mode 4, 7, 9: -
PZD-number	-
Parameter name	Control Mode 1: vpoc_Deadband_Type Control Mode 3: vprc_Deadband_Type Control Mode 4: - Control Mode 6: dcol_Deadband_Type Control Mode 7: - Control Mode 9: -
Data type	int8
Parameter length (byte)	1
Access	r/w

Value description

0	Deadband off
1	Deadband on

4.7.33 Deadband threshold A
Parameter description

Description	Deadband threshold A (= 'Deadband A' in PASO)	
IND	Control Mode 1:	21
	Control Mode 3:	22
	Control Mode 6:	11
	Control Mode 4, 7, 9:	-
PNU	Control Mode 1, 3:	113
	Control Mode 6:	101
	Control Mode 4, 7, 9:	-
PZD-number	-	
Parameter name	Control Mode 1:	vpoc_Deadband_ThresholdVal
	Control Mode 3:	vprc_Deadband_ThresholdVal
	Control Mode 4:	-
	Control Mode 6:	dcol_Deadband_ThresholdVal
	Control Mode 7:	-
	Control Mode 9:	-
Data type	Control Mode 1, 3:	uint16
	Control Mode 6:	uint32
Parameter length (byte)	Control Mode 1, 3:	2
	Control Mode 6:	4
Access	r/w	

Value Description

Range	0...16384 (corresponds 0 ... 50%)
Unit	Increment
Default Value	0
Step	32 (corresponds 0.1%)

4.7.34 Deadband threshold B
Parameter description

Description	Deadband threshold B	
IND	Control Mode 1:	21
	Control Mode 3:	22
	Control Mode 6:	11
	Control Mode 4, 7, 9:	-
PNU	Control Mode 1, 3:	254
	Control Mode 6:	102
	Control Mode 4, 7, 9:	-
PZD-number	-	
Parameter name	Control Mode 1:	vpoc_Deadband_Threshold_BsideVal
	Control Mode 3:	vprc_Deadband_Threshold_BsideVal
	Control Mode 4:	-
	Control Mode 6:	dcol_Deadband_Threshold_BsideVal
	Control Mode 7:	-
	Control Mode 9:	-
Data type	Control Mode 1, 3:	uint16

	Control Mode 6:	uint32
Parameter length (byte)	Control Mode 1, 3:	2
	Control Mode 6:	4
Access	r/w	

Value description

Range	0...16384 (corresponds 0 ... 50%)
Unit	Increment
Default Value	0
Step	32 (corresponds 0.1%)

4.7.35 Dither type

Parameter description

Description	Dither type	
IND	Control Mode 1:	21
	Control Mode 3, 4:	22
	Control Mode 6, 7, 9:	3
PNU	Control Mode 1, 3, 4:	187
	Control Mode 6, 7, 9:	97
PZD-number	-	
Parameter name	Control Mode 1:	vpoc_dither_Type
	Control Mode 3:	vprc_dither_Type
	Control Mode 4:	vprc_dither_Type
	Control Mode 6:	dop_dither_Type
	Control Mode 7:	dop_dither_Type
	Control Mode 9:	dop_dither_Type
Data type	int8	
Parameter length (byte)	1	
Access	r/w	

Value description

0	Dither off
1	Dither on with square function

4.7.36 Dither Frequency

Parameter description

Description	Dither Frequency (= 'Dither Frequency' in PASO)	
IND	Control Mode 1:	21
	Control Mode 3, 4:	22
	Control Mode 6, 7, 9:	3
PNU	Control Mode 1, 3, 4:	191
	Control Mode 6, 7, 9:	98
PZD-number	-	
Parameter name	Control Mode 1:	vpoc_dither_FreqVal
	Control Mode 3:	vprc_dither_FreqVal
	Control Mode 4:	vprc_dither_FreqVal
	Control Mode 6:	dop_dither_FreqVal
	Control Mode 7:	dop_dither_FreqVal
	Control Mode 9:	dop_dither_FreqVal
Data type	Control Mode 1, 3, 4:	uint16
	Control Mode 6, 7, 9:	uint32
Parameter length (byte)	Control Mode 1, 3, 4:	2
	Control Mode 6, 7, 9:	4

Access	r/w
--------	-----

Value description

Range	20 ... 500 = 20 ... 500Hz
Unit	Hz
Default Value	100 = 100Hz
Step	Only the following values are possible: 20, 25, 30, 35, 40, 45, 50, 55, 60, 70, 80, 100, 125, 165, 250, 500 The input will be rounded to a valid value

4.7.37 Dither Amplitude

Parameter description

Description	Dither Amplitude (= 'Dither Level' in PASO)
IND	Control Mode 1: 21 Control Mode 3, 4: 22 Control Mode 6, 7, 9: 3
PNU	Control Mode 1, 3, 4: 188 Control Mode 6, 7, 9: 101
PZD-number	-
Parameter name	Control Mode 1: vpoc_dither_AmplVal Control Mode 3: vprc_dither_AmplVal Control Mode 4: vprc_dither_AmplVal Control Mode 6: dop_dither_AmplVal Control Mode 7: dop_dither_AmplVal Control Mode 9: dop_dither_AmplVal
Data type	Control Mode 1, 3, 4: uint16 Control Mode 6, 7, 9: uint32
Parameter length (byte)	Control Mode 1, 3, 4: 2 Control Mode 6, 7, 9: 4
Access	r/w

Value description

Range	0...4266 (24V version: corresponds 400 mA) 0...2560 (12V version: corresponds 400 mA)
Unit	mA
Default Value	1072 (24V version: corresponds 100 mA) 640 (12V version: corresponds 100 mA)
Step	32 (24V version: corresponds 3.0 mA) (12V version: corresponds 5.0 mA)

4.7.38 System control

Parameter description

Description	System control (= 'System control' in PASO)
IND	Control Mode 1, 3, 6: - Control Mode 4, 7, 9: 3
PNU	Control Mode 1, 3, 6: - Control Mode 4, 7, 9: 131
PZD-number	-
Parameter name	Control Mode 1,3,6: - Control Mode 4,7,9: dop_drivePos_SystemInvert
Data type	uint8
Parameter length (byte)	1
Access	r/w

Value description

Range	0: System control not inverted 1: System control inverted
-------	--

4.7.39 Output Solenoid A
Parameter description

Description	Output solenoid A (= 'Output solenoid A' in PASO)
IND	Control Mode 1, 3, 6, 9: - Control Mode 4, 7: 3
PNU	Control Mode 1, 3, 6, 9: - Control Mode 4, 7: 132
PZD-number	-
Parameter name	Control Mode 1,3,6,9: - Control Mode 4,7: dop_Invert_MagA
Data type	uint8
Parameter length (byte)	1
Access	r/w

Value description

Range	0: Solenoid A not inverted 1: Solenoid A inverted
-------	--

4.7.40 Output Solenoid B
Parameter description

Description	Output Solenoid B (= 'Output solenoid B' in PASO) , only with 2 solenoids
IND	Control Mode 1, 3, 6, 9: - Control Mode 4, 7: 3
PNU	Control Mode 1, 3, 6, 9: - Control Mode 4, 7: 133
PZD-number	-
Parameter name	Control Mode 1,3,6,9: - Control Mode 4,7: dop_Invert_MagB
Data type	uint8
Parameter length (byte)	1
Access	r/w

Value description

Range	0: Solenoid B not inverted 1: Solenoid B inverted
-------	--

4.7.41 Imin always active

Parameter description

Description	Imin always active (= 'Imin always active' in PASO)
IND	Control Mode 1, 3, 6: - Control Mode 4, 7, 9: 3
PNU	Control Mode 1, 3, 6: - Control Mode 4, 7, 9: 134
PZD-number	-
Parameter name	Control Mode 1,3,6: - Control Mode 4,7,9: dop_imin_Active
Data type	uint8
Parameter length (byte)	1
Access	r/w

Value description

Range	0: no 1: yes
-------	-----------------

4.7.42 Solenoid 'In Position'

Parameter description

Description	Solenoid 'In Position' (= 'Solenoid 'In Position' in PASO)
IND	Control Mode 1, 3, 6: - Control Mode 4: 22 Control Mode 7: 13 Control Mode 9: 12
PNU	Control Mode 1, 3, 6: - Control Mode 4, 7, 9: 250
PZD-number	-
Parameter name	Control Mode 1, 3, 6: - Control Mode 4: vprc_window_solenoidInPos Control Mode 7: dsp_window_solenoidInPos Control Mode 9: dpc_window_solenoidInPos
Data type	uint8
Parameter length (byte)	1
Access	r/w

Value description

Range	0: Solenoids are not active inside the solenoid off window 1: Solenoids are also active inside the solenoid off window
-------	---

4.7.43 Signal type feedback value

Parameter description

Description	Signal type feedback value (= 'Signal type feedback value' in PASO)
IND	Control Mode 1, 3, 6: - Control Mode 4, 7, 9: 3
PNU	Control Mode 1, 3, 6: - Control Mode 4, 7, 9: 97
PZD-number	-
Parameter name	Control Mode 1,3,6: - Control Mode 4,7,9: dav_InterfaceType
Data type	uint8
Parameter length (byte)	1
Access	r/w

Value description

Range	Voltage input: 0: 0...10V Current input: 2: 0...20mA 3: 4...20mA Digital measuring system: 4: SSI-Gray 5: SSI-Binary 6: Start/Stop
-------	--

4.7.44 Used input feedback value

Parameter description

Description	Used input feedback value (= 'Used input feedback value' in PASO)
IND	Control Mode 1, 3, 6: - Control Mode 4, 7, 9: 1
PNU	Control Mode 1, 3, 6: - Control Mode 4, 7, 9: 20
PZD-number	-
Parameter name	dav_InterfaceNo
Data type	uint8
Parameter length (byte)	1
Access	r/w

Value description

Range	2: Analog input 3
-------	-------------------

4.7.45 Cablebreak feedback value

Parameter description

Description	Cablebreak feedback value (= 'Cablebreak feedback value' in PASO)
IND	Control Mode 1, 3, 6: - Control Mode 4, 7, 9: 1
PNU	Control Mode 1, 3, 6: - Control Mode 4, 7, 9: 96
PZD-number	-
Parameter name	dav_Cablebreak
Data type	uint8

Parameter length (byte)	1
Access	r/w

Value description

Range	0: Cablebreak detection off 1: Cablebreak detection on (only Signal type feedback value = 3)
-------	---

4.7.46 Displayed unit

Parameter description

Description	Displayed unit (= 'Displayed unit' in PASO)
IND	Control Mode 1, 3, 6: - Control Mode 4, 7, 9: 1
PNU	Control Mode 1, 3, 6: - Control Mode 4, 7, 9: 84
PZD-number	-
Parameter name	Control Mode 1, 3, 6: - Control Mode 4, 7, 9: dav_ActualValUnit
Data type	uint8
Parameter length (byte)	1
Access	r/w

Value description

Value	Control Mode		
	4 (Druck-Regelung)	7 (v-Regelung)	9 (Lage-Regelung)
0	bar	l/min	mm
1	psi	m/s	Grad
2	kN	Inch/s	Zoll
3	-	1/min	-
4	MPa	Grad/s	-

4.7.47 SSI-Transducer resolution

Parameter description

Description	Resolution of digitalen SSI transducer.
IND	Control Mode 1, 3, 6: - Control Mode 4, 7, 9: 1
PNU	Control Mode 1, 3, 6: - Control Mode 4, 7, 9: 41
PZD number	-
Parameter name	Control Mode 1, 3, 6: - Control Mode 4, 7, 9: dav_SSI_Resolution
Data type	uint32
Parameter length (byte)	4
Access	r/w

Value description

Range	100 ... 10'000'000
Unit	0.00001mm / Inc
Step	100 = 0.001mm
Default value	50'000 = 0.5mm / Inc

4.7.48 SSI-Transducer offset

Parameter description

Description	Offset of digital SSI transducer
IND	Control Mode 1, 3, 6: - Control Mode 4, 7, 9: 1
PNU	Control Mode 1, 3, 6: - Control Mode 4, 7, 9: 44
PZD number	-
Parameter name	Control Mode 1, 3, 6: - Control Mode 4, 7, 9: dav_SSI_Offset
Data type	uint32
Parameter length (byte)	4
Access	r/w

Value description

Range	0 ... 1'500'000
Unit	0.01 mm
Default value	0

4.7.49 SSI-Transducer bit count

Parameter description

Description	Bit-count of digital SSI transducer
IND	Control Mode 1, 3, 6: - Control Mode 4, 7, 9: 1
PNU	Control Mode 1, 3, 6: - Control Mode 4, 7, 9: 69
PZD number	-
Parameter name	Control Mode 1, 3, 6: - Control Mode 4, 7, 9: dav_SSI_Bitsize
Data type	uint8
Parameter length (byte)	1
Access	r/w

Value description

Range	1 .. 25
Default value	24

4.7.50 Start/Stop Transducer type

Parameter description

Description	Type of digital Start/Stop transducer
IND	Control Mode 1, 3, 6: - Control Mode 4, 7, 9: 1
PNU	Control Mode 1, 3, 6: - Control Mode 4, 7, 9: 69
PZD number	-
Parameter name	Control Mode 1, 3, 6: - Control Mode 4, 7, 9: dav_SS_Type
Data type	uint8
Parameter length (byte)	1
Access	r

Value description

Range	0: Double Resolution (25µm)
Default value	0

4.7.51 Start/Stop Transducer speed of sound
Parameter description

Description	Speed of sound of digital Start/Stop transducer
IND	Control Mode 1, 3, 6: - Control Mode 4, 7, 9: 1
PNU	Control Mode 1, 3, 6: - Control Mode 4, 7, 9: 65
PZD number	-
Parameter name	Control Mode 1, 3, 6: - Control Mode 4, 7, 9: dav_Start_Stop_C_Value
Data type	uint32
Parameter length (byte)	4
Access	r/w

Value description

Range	100 ... 500'000'000
Unit	0.01 mm/s
Default value	50'000 = 500mm/s

4.7.52 Start/Stop Transducer offset
Parameter description

Description	Offset of digital Start/Stop transducer
IND	Control Mode 1, 3, 6: - Control Mode 4, 7, 9: 1
PNU	Control Mode 1, 3, 6: - Control Mode 4, 7, 9: 105
PZD number	-
Parameter name	Control Mode 1, 3, 6: - Control Mode 4, 7, 9: dav_Start_Stop_Offset
Data type	uint32
Parameter length (byte)	4
Access	r/w

Value description

Range	0 ... 1'500'000
Unit	0.01 mm
Default value	0

4.7.53 Target window type

Parameter description

Description	Target window type (This parameter is not visible in the PASO)
IND	Control Mode 1, 3, 6: - Control Mode 4: 22 Control Mode 7: 13 Control Mode 9: 12
PNU	Control Mode 1, 3, 6: - Control Mode 4: 203 Control Mode 7: 149 Control Mode 9: 177
PZD-number	-
Parameter name	Control Mode 1, 3, 6: - Control Mode 4: vprc_window_Type Control Mode 7: dsp_window_Type Control Mode 9: dpc_window_Type
Data type	int8
Parameter length (byte)	1
Access	r/w

Value description

0	Window monitoring off
2	Window monitoring on

4.7.54 Target window threshold

Parameter description

Description	Target window threshold (= 'Target window threshold' in PASO)
IND	Control Mode 1, 3, 6: - Control Mode 4: 22 Control Mode 7: 13 Control Mode 9: 12
PNU	Control Mode 1, 3, 6: - Control Mode 4: 204 Control Mode 7: 150 Control Mode 9: 178
PZD-number	-
Parameter name	Control Mode 1, 3, 6: - Control Mode 4: vprc_window_ThresholdVal Control Mode 7: dsp_window_ThresholdVal Control Mode 9: dpc_window_ThresholdVal
Data type	int16
Parameter length (byte)	2
Access	r/w

Value description

Range	0 ... max. range (refer to section "Scaling" page 30)
Unit	Adjusted unit, refer to section "Displayed unit" page 62.
Default Value	10
Step	Dependent on the resolution of feedback value

4.7.55 Target window delay time

Parameter description

Description	Target window delay time (= 'Target window delay time' in PASO)
IND	Control Mode 1, 3, 6: - Control Mode 4: 22 Control Mode 7: 13 Control Mode 9: 12
PNU	Control Mode 1, 3, 6: - Control Mode 4, 7, 9: 232
PZD-number	-
Parameter name	Control Mode 1, 3, 6: - Control Mode 4: vprc_window_Delay Control Mode 7: dsp_window_Delay Control Mode 9: dpc_window_Delay
Data type	int16
Parameter length (byte)	2
Access	r/w

Value description

Range	0 ... 100
Unit	ms
Default Value	50
Step	1

4.7.56 Trailing window type

Parameter description

Description	Trailing window type (This parameter is not visible in the PASO)
IND	Control Mode 1, 3, 6: - Control Mode 4: 22 Control Mode 7: 13 Control Mode 9: 12
PNU	Control Mode 1, 3, 6: - Control Mode 4: 150 Control Mode 7: 112 Control Mode 9: 140
PZD-number	-
Parameter name	Control Mode 1, 3, 6: - Control Mode 4: vprc_Contr-Mon_Type Control Mode 7: dsp_Contr-Mon_Type Control Mode 9: dpc_Contr-Mon_Type
Data type	int8
Parameter length (byte)	1
Access	r/w

Value description

0	Target window monitoring off
2	Target window monitoring on

4.7.57 Trailing window threshold

Parameter description

Description	Trailing window threshold (= 'Trailing window threshold' in PASO)
IND	Control Mode 1, 3, 6: - Control Mode 4: 22 Control Mode 7: 13 Control Mode 9: 12
PNU	Control Mode 1, 3, 6: - Control Mode 4: 160 Control Mode 7: 122 Control Mode 9: 150
PZD-number	-
Parameter name	Control Mode 1, 3, 6: - Control Mode 4: vprc_Contr_Mon_Val Control Mode 7: dsp_Contr_Mon_Val Control Mode 9: dpc_Contr_Mon_Val
Data type	int16
Parameter length (byte)	2
Access	r/w

Value description

Range	0 ... max. range (refer to section "Scaling" page 30)
Unit	Adjusted unit, refer to section "Displayed unit" page 62.
Default Value	10
Step	Dependent on the resolution of feedback value

4.7.58 Trailing window delay time

Parameter description

Description	Trailing window delay time (= 'Trailing window delay time' in PASO)
IND	Control Mode 1, 3, 6: - Control Mode 4: 22 Control Mode 7: 13 Control Mode 9: 12
PNU	Control Mode 1, 3, 6: - Control Mode 4: 157 Control Mode 7: 119 Control Mode 9: 147
PZD-number	-
Parameter name	Control Mode 1, 3, 6: - Control Mode 4: vprc_Contr_Mon_Delay Control Mode 7: dsp_Contr_Mon_Delay Control Mode 9: dpc_Contr_Mon_Delay
Data type	int16
Parameter length (byte)	2
Access	r/w

Value description

Range	0 ... 100
Unit	ms
Default Value	50
Step	1

4.7.59 Solenoid off window threshold

Parameter description

Description	Solenoid off window threshold (= 'Solenoid off window threshold' in PASO)
IND	Control Mode 1, 3, 6: - Control Mode 4: 22 Control Mode 7: 13 Control Mode 9: 12
PNU	Control Mode 1, 3, 6: - Control Mode 4, 7, 9: 233
PZD-number	-
Parameter name	Control Mode 1, 3, 6: - Control Mode 4: vprc_Magn_Aus_Val Control Mode 7: dsp_Magn_Aus_Val Control Mode 9: dpc_Magn_Aus_Val
Data type	int16
Parameter length (byte)	2
Access	r/w

Value description

Range	0 ... max. range (refer to section "Scaling" page 30)
Unit	Adjusted unit, refer to section "Displayed unit" page 62.
Default Value	10
Step	Dependent on the resolution of feedback value

4.7.60 Solenoid off window delay time

Parameter description

Description	Solenoid off window delay time (= 'Solenoid off window delay time' in PASO)
IND	Control Mode 1, 3, 6: - Control Mode 4: 22 Control Mode 7: 13 Control Mode 9: 12
PNU	Control Mode 1, 3, 6: - Control Mode 4, 7, 9: 234
PZD-number	-
Parameter name	Control Mode 1, 3, 6: - Control Mode 4: vprc_Magn_Aus_Delay Control Mode 7: dsp_Magn_Aus_Delay Control Mode 9: dpc_Magn_Aus_Delay
Data type	int16
Parameter length (byte)	2
Access	r/w

Value description

Range	0 ... 100
Unit	ms
Default Value	50
Step	1

4.7.61 Internal resolution

Parameter description

Description	Current internal resolution (= 'Adjusting precision' for scaled parameter)
IND	Control Mode 1, 3, 6: - Control Mode 4: 22 Control Mode 7: 13 Control Mode 9: 12
PNU	Control Mode 1, 3, 6: - Control Mode 4, 7, 9: 254
PZD-number	-
Parameter name	Control Mode 1, 3, 6: - Control Mode 4: vprc_DeviceResolution Control Mode 7: dsp_DeviceResolution Control Mode 9: dpc_DeviceResolution
Data type	Control Mode 4 (Telegram type 3 and 4): int16 Control Mode 7, 9 (Telegram type 1 and 2): int32
Parameter length (byte)	2, 4
Access	r

Value description

Range	0...maxReference (refer to section "Min. Reference transducer" page 50)
Unit	-
Default Value	1000 (corresponds factor 1.000)
Step	Dependent on the unit (refer to section "Scaling" page 30)

4.7.62 Command Feed forward value

Parameter description

Description	Command Feed forward (= 'Preset value offering' in PASO)
IND	Control Mode 1, 3, 6: - Control Mode 4: 22 Control Mode 7: 13 Control Mode 9: 12
PNU	Control Mode 1, 3, 6: - Control Mode 4, 7, 9: 236
PZD-number	-
Parameter name	Control Mode 1, 3, 6: - Control Mode 4: vprc_SollwertAufschaltung Control Mode 7: dsp_SollwertAufschaltung Control Mode 9: dpc_SollwertAufschaltung
Data type	int16
Parameter length (byte)	2
Access	r/w

Value description

Range	0 ... 10000 (corresponds factor 0.000 ... 10.000)
Unit	-
Default Value	1000 (corresponds factor 1.000)
Step	100

4.7.63 Velocity feed forward value

Parameter description

Description	Velocity feed forward value (= 'Speed offering' in PASO)
IND	Control Mode 1, 3, 6: - Control Mode 4: 22 Control Mode 7: 13 Control Mode 9: 12
PNU	Control Mode 1, 3, 6: - Control Mode 4, 7, 9: 237
PZD-number	-
Parameter name	Control Mode 1, 3, 6: - Control Mode 4: vprc_GeschwAufschaltung Control Mode 7: dsp_GeschwAufschaltung Control Mode 9: dpc_GeschwAufschaltung
Data type	int16
Parameter length (byte)	2
Access	r/w

Value description

Range	0 ... 10000 (corresponds factor 0.000 ... 10.000)
Unit	-
Default Value	1000 (corresponds factor 1.000)
Step	100

4.7.64 I-part outside I-window

Parameter description

Description	I-part outside I-window (= 'I-part, if control difference > I-window outside' in PASO)
IND	Control Mode 1, 3, 6: - Control Mode 4: 22 Control Mode 7: 13 Control Mode 9: 12
PNU	Control Mode 1, 3, 6: - Control Mode 4, 7, 9: 235
PZD-number	-
Parameter name	Control Mode 1, 3, 6: - Control Mode 4: vprc_I_AnteilUnveraendert Control Mode 7: dsp_I_AnteilUnveraendert Control Mode 9: dpci_AnteilUnveraendert
Data type	int8
Parameter length (byte)	1
Access	r/w

Value description

0	Set the I-part to 0
1	Leave the I-part unchanged

4.7.65 P-amplification positive

Parameter description

Description	P-amplification positive (= 'P-amplf. positive' in PASO)
IND	Control Mode 1, 3, 6: - Control Mode 4: 22 Control Mode 7: 13 Control Mode 9: 12
PNU	Control Mode 1, 3, 6: - Control Mode 4: 238 Control Mode 7, 9: 106
PZD-number	-
Parameter name	Control Mode 1, 3, 6: - Control Mode 4: vprc_PVal Control Mode 7: dsp_PVal Control Mode 9: dpc_PVal
Data type	int16
Parameter length (byte)	2
Access	r/w

Value description

Range	0 ... 25000 (corresponds factor 0.0 ... 25.0)
Unit	-
Default Value	5000 (corresponds factor 5.0)
Step	100

4.7.66 P-amplification negative

Parameter description

Description	P-amplification negative (= 'P-amplft. negative' in PASO)
IND	Control Mode 1, 3, 6: - Control Mode 4: 22 Control Mode 7: 13 Control Mode 9: 12
PNU	Control Mode 1, 3, 6: - Control Mode 4, 7, 9: 239
PZD-number	-
Parameter name	Control Mode 1, 3, 6: - Control Mode 4: vprc_PValNeg Control Mode 7: dsp_PValNeg Control Mode 9: dpc_PValNeg
Data type	int16
Parameter length (byte)	2
Access	r/w

Value description

Range	0 ... 25000 (corresponds factor 0.0 ... 25.0)
Unit	-
Default Value	5000 (corresponds factor 5.0)
Step	100

4.7.67 Integrator type

Parameter description

Description	Integrator type (This parameter is not visible in the PASO)
IND	Control Mode 1, 3, 4, 6, 7: - Control Mode 9: 12
PNU	Control Mode 1, 3, 4, 6, 7: - Control Mode 9: 115
PZD-number	-
Parameter name	Control Mode 1, 3, 4, 6, 7: - Control Mode 9: dpc_integrator_Type
Data type	int8
Parameter length (byte)	1
Access	r/w

Value description

0	Switched integrator off
1	Standard switched integrator on

4.7.68 I-time positive

Parameter description

Description	I-time positive (= 'I-time positive' in PASO)
IND	Control Mode 1, 3, 6: - Control Mode 4: 22 Control Mode 7: 13 Control Mode 9: 12
PNU	Control Mode 1, 3, 6: - Control Mode 4: 240 Control Mode 7: 109 Control Mode 9: 116
PZD-number	-
Parameter name	Control Mode 1, 3, 6: - Control Mode 4: vprc_integrator_TiVal Control Mode 7: dsp_integrator_TiVal Control Mode 9: dpc_integrator_TiVal
Data type	int16
Parameter length (byte)	2
Access	r/w

Value description

Range	0 ... 10000
Unit	ms
Default Value	1000
Step	1

4.7.69 I-time negative

Parameter description

Description	I-time negative (= 'I-time negative' in PASO)
IND	Control Mode 1, 3, 6: - Control Mode 4: 22 Control Mode 7: 13 Control Mode 9: 12
PNU	Control Mode 1, 3, 6: - Control Mode 4, 7, 9: 241
PZD-number	-
Parameter name	Control Mode 1, 3, 6: - Control Mode 4: vprc_integrator_TiValNeg Control Mode 7: dsp_integrator_TiValNeg Control Mode 9: dpc_integrator_TiValNeg
Data type	int16
Parameter length (byte)	2
Access	r/w

Value description

Range	0 ... 10000
Unit	ms
Default Value	1000
Step	1

4.7.70 I-window outside positive

Parameter description

Description	I-window outside positive (= 'I-window outside positive' in PASO)
IND	Control Mode 1, 3, 6: - Control Mode 4: 22 Control Mode 7: 13 Control Mode 9: 12
PNU	Control Mode 1, 3, 6: - Control Mode 4, 7: 242 Control Mode 9: 119
PZD-number	-
Parameter name	Control Mode 1, 3, 6: - Control Mode 4: vprc_integrator_DXVal Control Mode 7: dsp_integrator_DXVal Control Mode 9: dpc_integrator_DXVal
Data type	int16
Parameter length (byte)	2
Access	r/w

Value description

Range	0 ... max. range (refer to section "Scaling" page 30)
Unit	Adjusted unit, refer to section "Displayed unit" page 62.
Default Value	5
Step	Dependent on the resolution of feedback value

4.7.71 I-window outside negative

Parameter description

Description	I-window outside negative (= 'I-window outside negative' in PASO)
IND	Control Mode 1, 3, 6: - Control Mode 4: 22 Control Mode 7: 13 Control Mode 9: 12
PNU	Control Mode 1, 3, 6: - Control Mode 4, 7, 9: 243
PZD-number	-
Parameter name	Control Mode 1, 3, 6: - Control Mode 4: vprc_integrator_DXValNeg Control Mode 7: dsp_integrator_DXValNeg Control Mode 9: dpc_integrator_DXValNeg
Data type	int16
Parameter length (byte)	2
Access	r/w

Value description

Range	0 ... max. range (refer to section "Scaling" page 30)
Unit	Adjusted unit, refer to section "Displayed unit" page 62.
Default Value	5
Step	Dependent on the resolution of feedback value

4.7.72 I-window inside positive

Parameter description

Description	I-window inside positive (= 'I-window inside positive' in PASO)
IND	Control Mode 1, 3, 6: - Control Mode 4: 22 Control Mode 7: 13 Control Mode 9: 12
PNU	Control Mode 1, 3, 6: - Control Mode 4, 7, 9: 248
PZD-number	-
Parameter name	Control Mode 1, 3, 6: - Control Mode 4: vprc_I_Fenster_Innen_Pos Control Mode 7: dsp_I_Fenster_Innen_Pos Control Mode 9: dpc_I_Fenster_Innen_Pos
Data type	int16
Parameter length (byte)	2
Access	r/w

Value description

Range	0 ... max. range (refer to section "Scaling" page 30)
Unit	Adjusted unit, refer to section "Displayed unit" page 62.
Default Value	0
Step	Dependent on the resolution of feedback value

4.7.73 I-window inside negative

Parameter description

Description	I-window inside negative (= 'I-window inside negative' in PASO)
IND	Control Mode 1, 3, 6: - Control Mode 4: 22 Control Mode 7: 13 Control Mode 9: 12
PNU	Control Mode 1, 3, 6: - Control Mode 4, 7, 9: 249
PZD-number	-
Parameter name	Control Mode 1, 3, 6: - Control Mode 4: vprc_I_Fenster_Innen_Neg Control Mode 7: dsp_I_Fenster_Innen_Neg Control Mode 9: dpc_I_Fenster_Innen_Neg
Data type	int16
Parameter length (byte)	2
Access	r/w

Value description

Range	0 ... max. range (refer to section "Scaling" page 30)
Unit	Adjusted unit, refer to section "Displayed unit" page 62.
Default Value	0
Step	Dependent on the resolution of feedback value

4.7.74 D-time positive

Parameter description

Description	D-time positive (= 'D-time positive' in PASO)
IND	Control Mode 1, 3, 6: - Control Mode 4: 22 Control Mode 7: 13 Control Mode 9: 12
PNU	Control Mode 1, 3, 6: - Control Mode 4, 7, 9: 244
PZD-number	-
Parameter name	Control Mode 1, 3, 6: - Control Mode 4: vprc_DTimeVal Control Mode 7: dsp_DTimeVal Control Mode 9: dpc_DTimeVal
Data type	int16
Parameter length (byte)	2
Access	r/w

Value description

Range	0 ... 10000
Unit	ms
Default Value	1000
Step	1

4.7.75 D-time negative

Parameter description

Description	D-time negative (= 'D-time negative' in PASO)
IND	Control Mode 1, 3, 6: - Control Mode 4: 22 Control Mode 7: 13 Control Mode 9: 12
PNU	Control Mode 1, 3, 6: - Control Mode 4, 7, 9: 245
PZD-number	-
Parameter name	Control Mode 1, 3, 6: - Control Mode 4: vprc_DTimeValNeg Control Mode 7: dsp_DTimeValNeg Control Mode 9: dpc_DTimeValNeg
Data type	int16
Parameter length (byte)	2
Access	r/w

Value description

Range	0 ... 10000
Unit	ms
Default Value	1000
Step	1

4.7.76 D-amplification positive

Parameter description

Description	D-amplification positive (= 'D-amplf. positive' in PASO)
IND	Control Mode 1, 3, 6: - Control Mode 4: 22 Control Mode 7: 13 Control Mode 9: 12
PNU	Control Mode 1, 3, 6: - Control Mode 4, 7, 9: 246
PZD-number	-
Parameter name	Control Mode 1, 3, 6: - Control Mode 4: vprc_DVal Control Mode 7: dsp_DVal Control Mode 9: dpc_DVal
Data type	int16
Parameter length (byte)	2
Access	r/w

Value description

Range	0 ... 10000 (corresponds factor 0.0 ... 10.0)
Unit	-
Default Value	5000 (corresponds factor 5.0)
Step	100

4.7.77 D-amplification negative

Parameter description

Description	D-amplification negative (= 'D-amplf. negative' in PASO)
IND	Control Mode 1, 3, 6: - Control Mode 4: 22 Control Mode 7: 13 Control Mode 9: 12
PNU	Control Mode 1, 3, 6: - Control Mode 4, 7, 9: 247
PZD-number	-
Parameter name	Control Mode 1, 3, 6: - Control Mode 4: vprc_DValNeg Control Mode 7: dsp_DValNeg Control Mode 9: dpc_DValNeg
Data type	int16
Parameter length (byte)	2
Access	r/w

Value description

Range	0 ... 10000 (corresponds factor 0.0 ... 10.0)
Unit	-
Default Value	5000 (corresponds factor 5.0)
Step	100

4.7.78 Feedback value

Parameter description

Description	Feedback value (Control Mode 4, -5, 7, 9) Feedback value position (Control Mode -10)
IND	Control Mode 1, 3, 6, -9: - Control Mode 4, -5: 22 Control Mode 7: 13 Control Mode 9: 12 Control Mode -10: 65
PNU	Control Mode 1, 3, 6: - Control Mode 4: 144 Control Mode 7, 9: 100
PZD-number	003
Parameter name	Control Mode 1, 3, 6, -9: - Control Mode 4, -5: vprc_ActualVal Control Mode 7: dsp_ActualVal Control Mode 9: dpc_ActualVal Control Mode -10: pq_ActualValPos
Data type	Control Mode 4, -5 (Telegram type 3 and 4): int16 Control Mode 7, 9, -10 (Telegram type 1, 2, 121, 122): int32
Parameter length (byte)	2, 4
Access	r

Value description

Range	Control Mode 1, 3, 6: - Control Mode 4 (Telegram type 3 and 4): 0 ... +16384 (refer to section "Internal bus resolution" page 31) Control Mode 7, 9 (Telegram type 1 and 2): 0...maxReferenz (refer to section "Max. Reference transducer" page 50)
Unit	Adjusted unit

4.7.79 Feedback value pressure
Parameter description

Description	Feedback value pressure
IND	Control Mode 1, 3, 4, -5, 6, 7, 9: - Control Mode -9, -10 65
PNU	Control Mode 1, 3, 4, -5, 6, 7, 9: - Control Mode -9, -10 144
PZD-number	123
Parameter name	Control Mode 1, 3, 4, -5, 6, 7, 9: - Control Mode -9, -10 pq_ActualValPres
Data type	Control Mode 1, 3, 4, -5, 6, 7, 9: - Control Mode -9, -10 (Telegram type 121, 122): 144
Parameter length (byte)	2
Access	r

Value description

Range	Control Mode 1, 3, 4, -5, 6, 7, 9: - Control Mode -9, -10 (Telegram type 121 and 122): 0 ... +16384 (refer to section "Internal bus resolution" page 31)
Unit	Adjusted unit

4.7.80 Control deviation
Parameter description

Description	Control deviation (Control Mode 4, -5, 7, 9) Control deviation position (Control Mode -9, -10)
IND	Control Mode 1, 3, 6, -9: - Control Mode 4, -5: 22 Control Mode 7: 13 Control Mode 9: 12 Control Mode -10: 65
PNU	Control Mode 1, 3, 6, -9: - Control Mode 4-5: 147 Control Mode 7, 9, -10: 103
PZD-number	-
Parameter name	Control Mode 1, 3, 6, -9: - Control Mode 4, -5: vprc_CtrlDeviationVal Control Mode 7: dsp_CtrlDeviationVal Control Mode 9: dpc_CtrlDeviationVal Control Mode -10: pq_CtrlDeviationPos
Data type	Control Mode 4, -5 (Telegram type 3 and 4): int16 Control Mode 7, 9, -10 (Telegram type 1, 2, 121, 122): int32

Parameter length (byte)	2, 4
Access	r

Value description

Range	Control Mode 1, 3, 6, -9: - Control Mode 4, -5 (Telegram type 3 and 4): 0 ... +16384 (refer to section "Internal bus resolution" page 31) Control Mode 7, 9, -10 (Telegram type 1, 2, 121, 122): 0...maxReferenz (refer to section "Max. Reference transducer" page 50)
Unit	Adjusted unit

4.7.81 Control deviation pressure
Parameter description

Description	Control deviation pressure
IND	Control Mode 1, 3, 4, -5, 6, 7, 9: - Control Mode -9, -10: 65
PNU	Control Mode 1, 3, 4, -5, 6, 7, 9: - Control Mode -9, -10: 147
PZD-number	-
Parameter name	Control Mode 1, 3, 4, -5, 6, 7, 9: - Control Mode -9, -10: pq_CtrlDeviationPres
Data type	Control Mode 1, 3, 4, -5, 6, 7, 9: - Control Mode -9, -10 (Telegram type 121, 122): int16
Parameter length (byte)	2
Access	r

Value description

Range	Control Mode 1, 3, 4, -5, 6, 7, 9: - Control Mode -9, -10 (Telegram type 121, 122): 0 ... +16384 (refer to section "Internal bus resolution" page 31)
Unit	Adjusted unit

4.7.82 Characteristic optimisation

Parameter description

Description	Characteristic optimisation (= "characteristic optimisation" in PASO) switch on or switch off. Can be switched on only if the characteristic optimisation possesses valid values (refer to section "Characteristic optimisation X-axis" and section "Characteristic optimisation Y-axis").
IND	64
PNU	20
PZD-number	-
Parameter name	
Data type	int8
Parameter length (byte)	1
Access	r/w

Value description

Characteristic optimisation switched off	0
Characteristic optimisation switched on	1

4.7.83 Characteristic optimisation X-axis

Parameter description

Description	Characteristic optimisation X axis (= 'Characteristic optimisation preset value' in PASO)
IND	64
PNU	21
PZD-number	-
Parameter name	
Data type	int32
Parameter length (byte)	4
Access	Stützpunkt 1: – (fixed value, refer to 'Range') 11: r (fixed 100) 2 ... 10: r/w

Value description

Range	Deadband type = 1 Mode of operation 0, 1, 2: Deadband A ... 100 Mode of operation 3 (2-Magnet einzeln): if solenoid choice A --> Totband A ... 100 if solenoid choice B --> Totband B ... 100 Deadband type = 0 0 ... 100 Condition: Values not sinkin Value [Base = 2] >= Value [Base = 1] Value [Base = 3] >= Value [Base = 2] usw.
Unit	%
Default Value	0
Step	1

The value consists of 4 bytes. It contains the solenoid choice, base and parameter values.

Byte 3	Byte 2	Byte 1	Byte 0
Solenoid A / B	base	empty	Parameter value

Example

The base 4 of the solenoid B with the value 50 is to be described:

Byte 3	Byte 2	Byte 1	Byte 0
1 (Solenoid B)	4	empty	50

Hex. 01 04 00 32
 Value = 01 04 00 32 H

or

Dez. $1 * 2^{24}$ + $4 * 2^{16}$ + $0 * 2^8$ + 50
 ↑ ↑ ↑
 Shift 24 Bit Shift 16 Bit Shift 8 Bit
 to the left to the left to the left

Value = 17039410 D

After a change of the parameter "Deadband threshold A", the characteristic optimisation parameters of the X axis are no longer valid. The parameters must be read or set again.

For reading, the parameter "Characteristic optimisation of solenoid choice" and "Characteristic optimisation of base" must be set first.

4.7.84 Characteristic optimisation Y-axis

Parameter description

Description	Characteristic optimisation Y-axis (= 'Characteristic-solenoid current' in PASO)
IND	64
PNU	22
PZD-number	-
Parameter name	
Data type	int32
Parameter length (byte)	4
Access	Base 1: r (fest 0) 11: r (fest 1000) 2 ... 10: r/w

Value description

Range	Base 1: 0 (corresponds Imin) 11: 1000 (corresponds Imax) 2 ... 10: 0 ... 1000 (corresponds Imin ... Imax)
Unit	1/10 %
Default Value	0
Step	1

The value consists of 4 bytes. It contains the solenoid choice, base and parameter values.

Byte 3	Byte 2	Byte 1	Byte 0
Solenoid A / B ¹	Base	Parameter value	

Example

The base 8 of the solenoid A with the value 700 is to be described:

Byte 3	Byte 2	Byte 1	Byte 0
0 (Solenoid A)	8	700	

Hex. 00 08 02 BC
 Value = 00 08 02 BC H

or

Dez. 0 * 2²⁴ + 8 * 2¹⁶ + 700
 ↑ ↑
 Shift 24 Bit Shift 16 Bit
 to the left to the left

Value = 524988 D

For reading, the parameter "Characteristic optimisation of solenoid choice" and "Characteristic optimisation of base" must be set first.

¹ Magnet B nur wenn 2-Magnete

4.7.85 Characteristic optimisation of solenoid choice

Parameter description

Description	Characteristict optimisation of solenoid choice
IND	64
PNU	24
PZD-number	-
Parameter name	
Data type	int8
Parameter length (byte)	1
Access	r/w

Value description

0	Solenoid A
1	Solenoid B

The value is maintained, until it is overwritten with a new value or the SD6 electronics is switched off.

4.7.86 Characteristict optimisation of base

Parameter description

Description	Characteristict optimisation of base
IND	64
PNU	23
PZD-number	-
Parameter name	
Data type	int8
Parameter length (byte)	1
Access	r/w

Value description

Range	1...11 (corresponds base 1...11)
-------	----------------------------------

The value is maintained, until it is overwritten with a new value or the SD6 electronics is switched off .

5 Commissioning

For a support during the commissioning of a DP-Slave controller card, the parameterisation software PASO can be connected to the DP-Slave controller card. PASO offers the possibility to display some process value like preset value, solenoid current, device state (state machine) etc. Also the setting of the node address and a PROFIBUS-DP diagnostic can be made via the PASO (refer to section "Fieldbus Settings" page 9).

5.1 Step by step instructions for the first commissioning

For the first commissioning, the following steps should be observed:

5.1.1 Test the hydraulic system

1. Switch off the hydraulic system
2. Switch off the fieldbus master
3. Switch on the SD6
4. In the PASO window "Fieldbus_Fieldbus-Info" in the section "Bus State" the following statement will be displayed: WD-Status = Baud_Search and DP-status = Wait_Prm (refer to section "Fieldbus Settings" page 9)
 1. In the PASO status line, the statements "Local" and "Init" will be displayed
 2. Switch on the hydraulic system
 3. Set the control of the device to PASO with the PASO Menu "Commands_PASO Control". In the PASO status line, the statements "Remote PASO" and "Init" will be displayed
 4. Enable the device with the PASO Menu "Commands_Enable". In the PASO status line, the statements "Remote PASO" and "Active" will be displayed
 5. Über den PASO Menubefehl "Befehle_Ventilbetätigung" kann nun direkt ein Magnetstrom vorgegeben werden.

IMPORTANT: The hydraulic moves in an open loop system! Be sure, that the hydraulic system can move free.

6. In the PASO window "Parameters_Valves", the parameters for the minimum (Imin) and maximum (Imax) current and the dither signal (frequency and level) can be set
7. Disable the device with the PASO Menu "Commands_Disable". In the PASO status line, the statements "Remote PASO" and "Disabled" will be displayed
8. Set the control of the device to Local with the PASO Menu "Commands_Local Control". In the PASO status line, the statements "Remote" and "Init" will be displayed

5.1.2 Connect the measuring system (only SD6 controller)

1. Connect the measuring system to the corresponding input of the SD6
2. In the PASO window "Configuration_Control mode", the adjustments for the desired control mode can be made
3. In the PASO window "Configuration_Signal scaling", the adjustments for the feedback value signal can be made

5.1.3 Adjust the mode of operation (only SD6 amplifier)

1. In the PASO window "Configuration_Mode of operation", the adjustments for the desired mode of operation can be made

5.1.4 Test the fieldbus

2. Load the GSD-Datei in the fieldbus master and select the desired telegram type (refer to section „Presupposition and information for the Fieldbus master“ page 86)
3. Adjust the node address and the telegram type (refer to section "Presupposition for the DP-Slave controller card" page 86)
4. Switch on the fieldbus master
5. In the PASO window „fieldbus_Fieldbus-Info“ in the section „Bus State“ the following statement will be displayed: WD-Status = DP_Control and DP-Status = Data-Exchange (refer to section "Fieldbus Diagnostics" page 10)

5.1.5 Test the control via the fieldbus

1. Set the following parameter in the declared order with the PKW-services (refer to section "Cyclical parameter data exchange (PKW) " page 27)
2. Set the parameter "Device local" to "Control operation via BUS (0)" (refer to section "Device local" page 42)
3. With the parameter „Device control mode“ page 42).
4. For the release of the SD6, the 3 bits "Disable (D)", "Hold enable (H)" and "Device mode active (M)" from the control word (refer to section "Control Word" page 40) must be set to logical 1. The DP-Slave controller is now in the state "ACTIVE".
5. With the PKW-services (refer to section "Cyclical parameter data exchange (PKW)" page 27) resp. the PZD-services (refer to section "Cyclical process data exchange (PZD) " page 22) a preset value can now be set via the fieldbus.

5.2 Presupposition for the DP-Slave controller card

For the commissioning of a DP-Slave controller card, the following presupposition must be cleared:

- **What is the node adresse from the DP-Slave controller card?**
The node address can be set via the parameterisation software PASO in the menu item "Fieldbus_Fieldbus-Info" (refer to section "Fieldbus Settings" page 9).
- **What is the device control mode for the DP-Slave controller card?**
The device control mode can be set via the parameter "". This selection is important for the for the function range of the DP-Slave controller card.

IMPORTANT: This parameter can only be changed if the SD6 is in the state "INIT" or "DISABLE" (refer to section "State machine" page 16)

- **Telegram**
If the mode of operation is selected, the corresponding telegram must be selected. This adjustment can only be made if the SD6 electronic is separated from the Profibus.

5.3 Presupposition and information for the Fieldbus master

For the commissioning of a Fieldbus master, the following presupposition must be cleared:

- **Node address**
What is the node address from the DP-Slave?
- **Telegram**
The master must be adjusted to the same type of telegram as the SD6 Electronics.
- **GSD-file**
The GSD-file "WAG400BB.gsd" must be present on the Master side. If not, this file must be copied into the project tool of the Master.
- **Data exchange (consistent / inconsistent)**
For the programming of the data exchange (consistent / inconsistent) in the application program of the master, the following rules are valid:
 - PKW-part
→ consistent data transfer (consistent for the whole length)
 - PZD-part
→ consistent data transfer (consistent for the whole length)

5.4 Delivery state

The SD6 is delivered with the following basic configuration:

Device	Address	Telegram type
SD6 Amplifier	6	3
SD6 Controller	6	1

5.5 Parameterisation

The parameters of the DP-Slave controller card can be read or changed through the PROFIBUS-DP or through PASO.

After switch-on the DP-Slave controller card, it can be parameterised by sending parameter via PKW (refer to section "Cyclical parameter data exchange (PKW)" page 27). If the changed parameters should be also present after a switch-Off and switch-on, they must be stored before the switch-Off. This can be made with the parameter "Store Parameter" (refer to section "Store Parameter" page 43).

5.6 Setting the preset value via Fieldbus

In the standard version of the DP-Slave controller card, the preset value can be set locally or via the Fieldbus (refer to section "Program Control" page 19). The switch over is made with the parameter "db_DeviceMode" (refer to section "Device mode" page 42)

After each power on, the following commissioning sequence is necessary:

1. The DP-Slave controller card is now in the state "INIT"
2. In this state, the device control mode can be set with the parameter "db_ControlMode" and the device mode can be set with the parameter "db_DeviceMode"
3. For the release of the DP-Slave controller card, the 3 bits D, H and M from the control word (refer to section "State machine" page 16) must be set to logical 1. The DP-Slave controller card is now in the state "ACTIVE". Now, a preset value can be set.

Note: If the DP-Slave controller card is used locally (refer to section "Local control" page 14), the start signal (digital input 1) must be set additionally

5.7 Start after an error

- If the device detects an error, the release will be take away internal and the bit "Ready" from the status word will be set to 0. Via the parameter "Error Code" or via the menu item "Diagnostic" in the PASO, an error description can be displayed.
- For restarting the DP-Slave controller card, the bit "Reset Fault" in the control word must be set once to logical 1. Therefore, the error will be reset.
- If the error is reset, the bit "Ready" from status word will be set to 1.
- For the release of the DP-Slave controller card, the 3 bit D, H and M from the control word must be set again to logical 1

6 Diagnostic and error detection

6.1 Diagnostic about the Fieldbus

A diagnostic about the Fieldbus is always possible via the parameterisation software PASO. This will be made via the menu item "Fieldbus_Fieldbus-Info". The following values will be displayed:

- Node address
- Baudrate
- Telegram type
- Bus type
- ID-number
- WD-state
- DP-state
- TG-state
- PDZ-values

A detailed description of the diagnostic function you will find in the section "Fieldbus Diagnostics" page 10.

7 Version index

In the following table, an index about the different versions of the "OPERATING INSTRUCTIONS SD6 PROFIBUS-DP Device-Profile in accordance with Fluid Power Technology" will be listed. The current version is always the version listed at last.

Version	Bezeichnung	Datum der Freigabe
0.1	Start Version (Acquisition of DSV)	08.09.04
1.0	Supplemented with changes relating the SD6	29.11.04
2.0	Supplemented in the area of Profibus	14.11.08
2.1	Supplemented with pQ-controller	may 2011