

OPERATING INSTRUCTIONS

ENHANCED CONTROLLER MODULE SD6

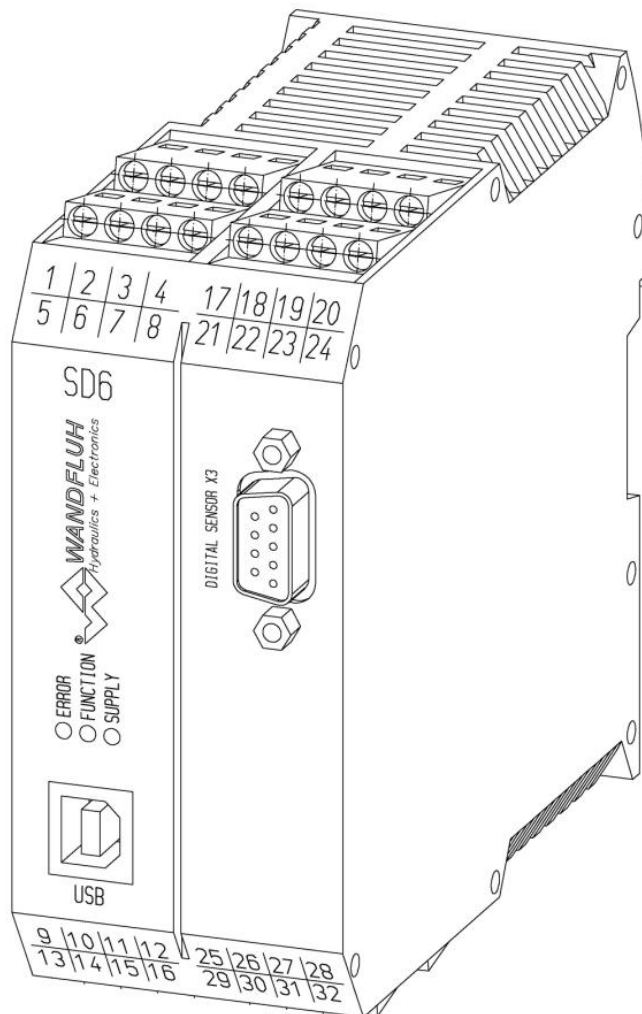

Contents

1	General information	3
2	Product description	3
2.1	General.....	3
2.2	Field of application.....	3
2.3	Conformity.....	3
2.4	Labelling of the product.....	3
2.5	Type code.....	4
2.6	Technical Data.....	5
2.7	Block diagram.....	8
3	Safety rules	9
3.1	Installation / Commissioning / Parameterisation.....	9
4	Construction and Function	10
4.1	Introduction.....	10
4.2	Description of the Function.....	10
4.3	Characteristic optimisation.....	10
4.4	SD6 State machine.....	11
4.5	Operating mode.....	12
4.6	Analogue inputs.....	12
4.7	Cablebreak detection.....	13
4.8	Digital inputs.....	13
4.9	Input for digital sensor.....	14
4.10	Outputs.....	15
4.11	Controller Modes.....	15
4.12	Mode of operation.....	21
5	Operating and Indicating elements	23
5.1	General.....	23
5.2	Screw terminator view.....	23
5.3	Control elements.....	24
6	Commissioning	26
6.1	Connection instructions.....	26
6.2	Connection examples.....	28
7	Settings	29
7.1	Introduction.....	29
7.2	Tips for the first commissioning.....	29
7.3	Start up help.....	30
7.4	Default settings.....	32
7.5	File-Menu.....	34
7.6	Profile-Menu.....	37
7.7	Parameters-Menu.....	43
7.8	Configuration-Menu.....	52
7.9	Commands-Menu.....	71
7.10	Fieldbus-Menu.....	73
7.11	Setup mode.....	73
7.12	Analysis-Menu.....	74
7.13	Help-Menu.....	79
8	System does not work	80
8.1	Procedure.....	80
9	PASO DSV/SD6 Installation and Operation	81
9.1	System presupposition.....	81
9.2	Installation.....	81
9.3	Connection to the Wandfluh card.....	81
9.4	Mode "Off Line" and "On Line".....	82
9.5	Communication start up.....	82
9.6	Communication interruption.....	83
9.7	Program description.....	84
9.8	Starting of PASO DSV/SD6.....	86
9.9	Store parameter.....	87
9.10	Limiting value error.....	87
9.11	Description of Commands.....	88
10	Disposal	89
11	Additional information	89

1 General information

This operating instructions makes it possible to use the SD6-Electronics safely and according to specification. The operating instructions includes instructions which Wandfluh as the manufacturer, or its resale organisations (Wandfluh sister companies or distributors), provide to users within their duty to instruct.

For this purpose, the operating instructions mainly includes:

- information about use according to specification, installation and commissioning of the SD6-Electronics
- information about safety in dealing with control.

2 Product description

2.1 General

The SD6-Electronics is integrated in a case for top-hat rail fastening. The connections are provided by terminal screw blocks.

2.2 Field of application

The field of application of the SD6-Electronics is situated in the industrial field.

2.3 Conformity

The SD6-Electronics have been developed and tested in accordance with the latest technical standards. Applied in particular was the EU Guideline 2004/108/EG (EMC Guideline).

2.4 Labelling of the product

With the PC parameterisation software PASO DSV/SD6, the following information can be directly read-off the SD6-Electronics (=electronic type code):

- Part number
- Serial number
- Software version
- Firmware version
- Card type
- Hardware configuration

2.5 Type code

		S	D6	3	<input type="checkbox"/>	2	<input type="checkbox"/>	<input type="checkbox"/>	-	<input type="checkbox"/>	#	<input type="checkbox"/>
Module for electrical control cubicle												
Digital												
Parameters to be set with PASO												
Software configuration (function of card):												
• Basic controller	<input type="checkbox"/>											
• Enhanced controller	<input type="checkbox"/>											
2-solenoid version												
Supply voltage:	24 VDC	<input type="checkbox"/>										
	12 VDC	<input type="checkbox"/>										
Digital controller module Basic:												
• Analogue input 1: voltage; Analogue input 2: current	<input type="checkbox"/>											
• Analogue input 1 and 2: both voltage	<input type="checkbox"/>											
• Analogue input 1 and 2: both current	<input type="checkbox"/>											
Digital controller module Enhanced:												
• Analogue input 1 and 3: both voltage	<input type="checkbox"/>											
• Analogue input 2 and 4: both current	<input type="checkbox"/>											
• Analogue input 1 to 4: all voltage	<input type="checkbox"/>											
• Analogue input 1 to 4: all current	<input type="checkbox"/>											
• Analogue input 1 and 2: both voltage Analogue input 3 and 4: both current	<input type="checkbox"/>											
• Analogue input 1 and 2: both voltage Analogue input 3 and 4: both current	<input type="checkbox"/>											
Digital controller module Basic:												
• Analogue input 1 und 2: 10-Bit resolution	<input type="checkbox"/>											
Digital controller module Enhanced:												
• Analogue input 1 and 2: 10-Bit resolution Analogue input 3 and 4: 16-Bit resolution	<input type="checkbox"/>											
Option field bus:												
• without field bus (with analogue input signal)	<input type="checkbox"/>											
• with Profibus DP	<input type="checkbox"/>											
Design-Index (Subject to change)												

2.6 Technical Data

2.6.1 General specifications

Design	Integrated in electronic case for top-hat rail clamping
Dimension	Amplifier and Basic Controller: 105 x 114 x 22.5mm Enhanced Controller: 105 x 114 x 45mm Amplifier and Controller with Profibus: 105 x 114 x 45mm
Mounting	For top-hat rail clamping
Weight	Amplifier and Basic Controller: 130g Enhanced Controller: 220g Amplifier and Controller with Profibus: 240g
Connection	Terminal screw blocks, max dimension 2.5mm ² 1 USB interface (connector type B)
Protection class	IP30 acc. to EN 60 529

2.6.2 Electrical specifications

Supply voltage (depending on the type)	24 VDC or 12 VDC										
Voltage range	Supply voltage 24 VDC: 21 ... 30 VDC Supply voltage 12 VDC: 10.5 ... 15 VDC										
Ripple on supply voltage	< ±5 %										
Fuse	Customer must integrate a slow fuse into his electrical system										
Temperature drift	< 1% with ΔT = 40°C										
No load current	40 ... 50 mA										
Max. solenoid current	24VDC version 1.8 A 12VDC version 2.3 A										
Analogue inputs	<p>2 differential inputs 10-Bit (analogue input 1 + 2) 2 differential inputs 16-Bit (analogue input 3 + 4) All inputs are not galvanically separated</p> <table border="0"> <tr> <td>SD6362DX4-BX</td> <td>Analogue input 1: 0...±10VDC Analogue input 2: 0...20mA, 4...20mA Analogue input 3: 0...±10VDC Analogue input 4: 0...20mA, 4...20mA</td> </tr> <tr> <td>SD6362DX5-BX</td> <td>Analogue input 1: 0...±10VDC Analogue input 2: 0...±10VDC ** Analogue input 3: 0...±10VDC Analogue input 4: 0...±10VDC</td> </tr> <tr> <td>SD6362DX6-BX</td> <td>Analogue input 1: 0...20mA, 4...20mA Analogue input 2: 0...20mA, 4...20mA Analogue input 3: 0...20mA, 4...20mA Analogue input 4: 0...20mA, 4...20mA</td> </tr> <tr> <td>SD6362DX8-BX</td> <td>Analogue input 1: 0...±10VDC Analogue input 2: 0...±10VDC Analogue input 3: 0...20mA, 4...20mA Analogue input 4: 0...20mA, 4...20mA</td> </tr> <tr> <td>SD6362DX8-BX</td> <td>Analogue input 1: 0...20mA, 4...20mA Analogue input 2: 0...20mA, 4...20mA Analogue input 3: 0...±10VDC Analogue input 4: 0...±10VDC</td> </tr> </table> <p>**) 0...10VDC on SD6 with Profibus</p>	SD6362DX4-BX	Analogue input 1: 0...±10VDC Analogue input 2: 0...20mA, 4...20mA Analogue input 3: 0...±10VDC Analogue input 4: 0...20mA, 4...20mA	SD6362DX5-BX	Analogue input 1: 0...±10VDC Analogue input 2: 0...±10VDC ** Analogue input 3: 0...±10VDC Analogue input 4: 0...±10VDC	SD6362DX6-BX	Analogue input 1: 0...20mA, 4...20mA Analogue input 2: 0...20mA, 4...20mA Analogue input 3: 0...20mA, 4...20mA Analogue input 4: 0...20mA, 4...20mA	SD6362DX8-BX	Analogue input 1: 0...±10VDC Analogue input 2: 0...±10VDC Analogue input 3: 0...20mA, 4...20mA Analogue input 4: 0...20mA, 4...20mA	SD6362DX8-BX	Analogue input 1: 0...20mA, 4...20mA Analogue input 2: 0...20mA, 4...20mA Analogue input 3: 0...±10VDC Analogue input 4: 0...±10VDC
SD6362DX4-BX	Analogue input 1: 0...±10VDC Analogue input 2: 0...20mA, 4...20mA Analogue input 3: 0...±10VDC Analogue input 4: 0...20mA, 4...20mA										
SD6362DX5-BX	Analogue input 1: 0...±10VDC Analogue input 2: 0...±10VDC ** Analogue input 3: 0...±10VDC Analogue input 4: 0...±10VDC										
SD6362DX6-BX	Analogue input 1: 0...20mA, 4...20mA Analogue input 2: 0...20mA, 4...20mA Analogue input 3: 0...20mA, 4...20mA Analogue input 4: 0...20mA, 4...20mA										
SD6362DX8-BX	Analogue input 1: 0...±10VDC Analogue input 2: 0...±10VDC Analogue input 3: 0...20mA, 4...20mA Analogue input 4: 0...20mA, 4...20mA										
SD6362DX8-BX	Analogue input 1: 0...20mA, 4...20mA Analogue input 2: 0...20mA, 4...20mA Analogue input 3: 0...±10VDC Analogue input 4: 0...±10VDC										

Input resistance	Voltage input against ground Burden for current input	> 18 kOhm = 250 Ohm
Input for digital sensors	9-pin D-SUB connector with RS-422 interface for SSI and Start/Stop sensors	
Digital inputs	8 inputs active-high Switching threshold high Switching threshold low	6 - 30VDC 0 - 1VDC
Serial interface	1 USB interface (Connector Type B)	
Stabilised output voltage	Supply voltage 24 VDC: Supply voltage 12 VDC:	+ 10 VDC + 8 VDC max. load 30 mA
Solenoid current	Minimum current I _{min} adjustable Maximum current I _{max} adjustable - Supply voltage 24 VDC: - Supply voltage 12 VDC:	0 ... 950 mA I _{min} ... max. 1.8 A I _{min} ... max. 2.3 A
Dither	Frequency adjustable Level adjustable	20 ... 250 Hz 0 ... 200 mA
Analogue output	Output voltage range max. load	+/- 10 VDC +/- 3 mA
Digital outputs	4 outputs Lowside Switch. U _{max} I _{max}	40 VDC -0.7 A
EMC Immunity Emission	EN 61000-6-2 EN 61000-6-4	

2.6.3 Environment

Storage	packing:	The module must be stored in the original packing
	Temperature range:	-25 ... +85° C
In operation	Resistance to alkali and acid:	The module must be protected against alkalis and acids
	Temperature range	-20 ... +70° C The total solenoid current of simultaneously powered solenoids depends on the ambient temperature. Further information can be found in chapter Solenoid outputs and ambient temperature ^[7] .
	Resistance to alkali and acid:	The module must be protected against alkalis and acids

2.6.4 Solenoid Outputs and Ambient Temperature

If only one solenoid output is powered at a time, then there are no restrictions and the single solenoid current may reach the maximum current according to the [Electrical Specifications](#) over the whole temperature range.

But the total solenoid current of simultaneously powered solenoids depends on the ambient temperature. Exceeding this current limit will trip the overcurrent protection circuit, the SD6 falls into the failure state and blocks all function.

Solenoids can be powered simultaneously, i.e. on the amplifier in operating mode 4, or with inverted solenoid outputs.

If solenoids are powered with more voltage than their nominal voltage and are so over-energized, then at fast switching-on, the overcurrent protection may trip and the SD6 may fall into failure state and block all function.

The following graphics shows the maximum allowed total solenoid current over ambient temperature when both solenoids are powered at the same time.

SD6: Derating of Total Solenoid Current when both Solenoid Outputs activated simultaneously

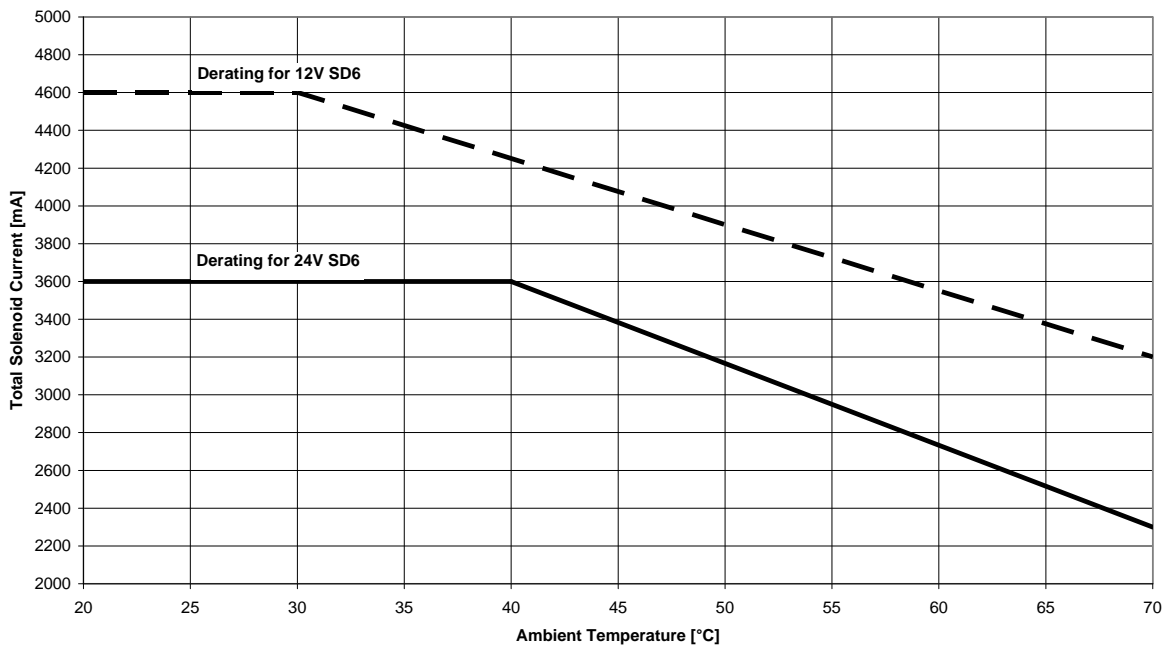

2.7 Block diagram

Driving through the analogue interface

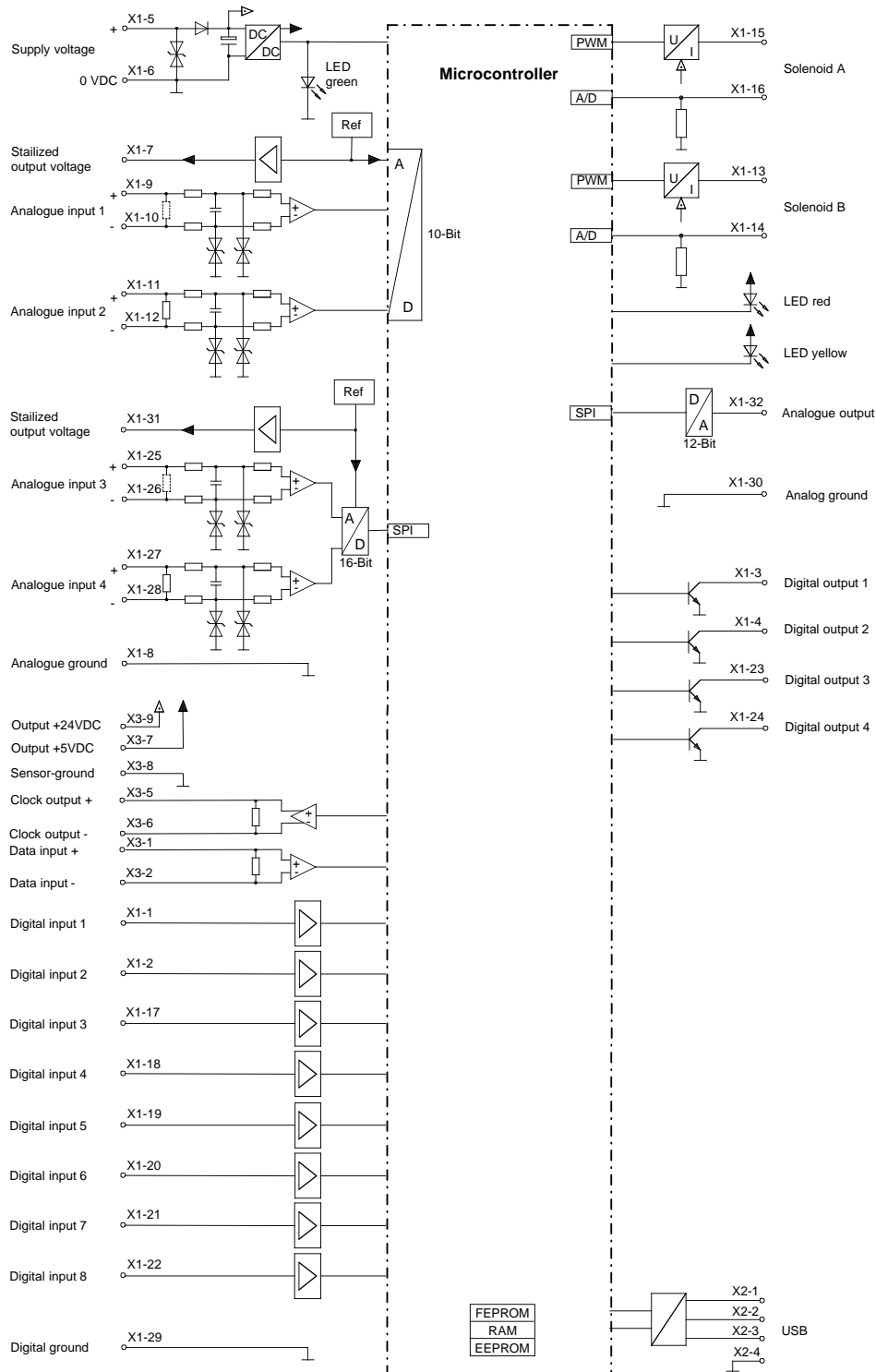

3 Safety rules

3.1 Installation / Commissioning / Parameterisation

- These operating instructions have to be carefully studied beforehand and the instructions are to be complied with.
- Prior to the installation, all power supply voltages and any other energy sources have to be disconnected.
- The installation/assembly must only be carried out by specialist personnel with electrical knowledge.
- Take into account precautionary measures concerning components on the module, which are subject to damage as a result of electrostatic discharge.
- Wrong manipulations by the personnel cannot be prevented by the SD6-Electronics.
- Before the switching on of the supply voltage, the fuse protection, the correct wiring and the conformity of the power supply voltage with the permissible supply voltage range have to be verified.



- **The SD6-Electronics monitors the working conditions within the electronics and within the installation. Uncontrolled movements or force changes caused by unforeseen errors of the SD6-Electronics cannot be prevented in any case.**
- **Danger for persons has to be avoided by installing an emergency stop device which cuts off the power to the system.**

4 Construction and Function

Refer to section ["Block diagram"](#) .

4.1 Introduction

- All inputs and outputs have to be contacted through the terminal screw block
- At the device front panel, there is a USB interface, through which the parameterisation and the diagnostics can be made by using the PC-Parameterisation software PASO DSV/SD6
- In the factory, the SD6-Electronics are adjusted with the default values. The adjustment to the valves being used, has to be performed by the user.

4.2 Description of the Function

With the SD6-Electronics, it is possible to build different closed circuit controls. Apart from controls for pressure, volume flow or position, also pQ- and alternating controls can be implemented. They can optionally be adjusted in the form of a controller mode. In addition, an amplifier part is integrated, with which the connected valve resp. its solenoid is directly driven.

The command value is conducted to the controller as an electric signal, a sensor records the feedback value, this signal is also conducted to the controller. In correspondence with the control difference (command value - feedback value), a control signal (solenoid current) is output to the valve.

By means of the scaling of the command value and feedback value, all further inputs can be made in the required, resp., selectable physical unit (e.g., bar or mm, etc.). When the command value has been reached, then the SD6 is capable of outputting a digital signal (optionally an „Error“- or „Target window reached “ - signal).

The SD6 - controller has a command value generator, with which the up - and down ramp of the internal command value can be predefined. The controller is designed as a PID - controller. The control characteristics as a result of this can be equalised and adapted to the control circuit. Furthermore, it is also possible to switch-off the control system completely for testing - and adjusting purposes. The SD6 in this case operates in correspondence with normal amplifier electronics.

Furthermore the controller module “SD6” comprises digital inputs for the enabling, for controlling the manual operation and for the profile generator as well as digital outputs, which output the conditions „Error“ or „Target window reached “.

Changed parameters can be saved in a non-volatile memory, so that following a renewed switching-on of the control system they are still available once again.

The SD6 - electronics in addition have a signal recording function. By means of PASO, this makes possible a recording of different system signals, such as, e.g., command value / feedback value, control difference, solenoid currents, etc., which are able to be graphically displayed on a common time axis.

The manual operating mode makes available commands such as Forwards, Backwards, Rapid Speed and Creep Speed. With this it is possible to put the connected hydraulics into operation without a super-ordinate control system.

4.3 Characteristic optimisation

The SD6 electronics are provided with a possibility to optimise the characteristic “Preset value input – solenoid current output”. The user is able to create a characteristic (e.g. a linearised characteristic) which matches his own application. The characteristic optimisation can be turned on or off (refer to “Parameters_Valves” on page 21). This setting is available only with a SD6-electronics with software version higher than 1.1.1.6 and PASO with software version higher than 1.5.0.9!

4.4 SD6 State machine

In the following, with the help of a status diagram it is described, how the start-up of the SD6-Electronics takes place and which statuses are reached when and how.

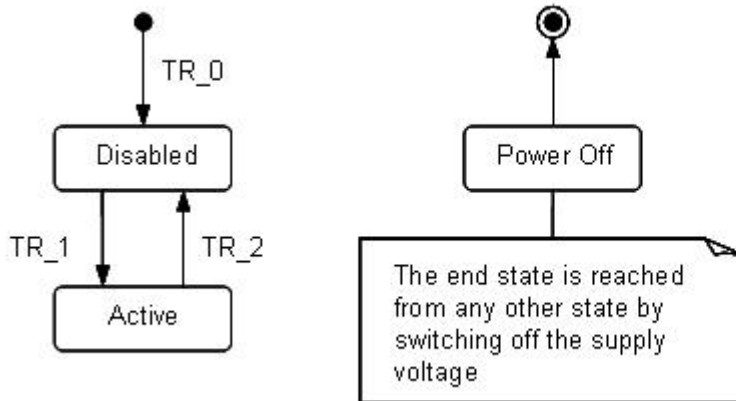

The following table describes the possible statuses and what is done in these statuses:

Status	Description
Disabled	<ul style="list-style-type: none"> The SD6-Electronics are disabled, no solenoid current will be active In this state, with the command "Local operation" resp. "PASO operation" (refer to section "Commands_Local Operating / PASO" ^[72]) the operating mode can be set.
Active	<ul style="list-style-type: none"> The SD6-Electronics are enabled The SD6-Electronics can be operated according to the selected operating mode Changing the operating mode is not possible

The following table describes the transitions from one status to the next one:

Transition	Description
TR_0	Switching-on the supply voltage
TR_1	Enable This is made in the operating mode "Local" through the digital input "Enable control" (refer to section "Digital inputs" ^[13]) and in the operating mode "Remote PASO" through the command "Enable" (refer to section "Commands_Disable / Enable" ^[72]).
TR_2	Disable This is made in the operating mode "Local" through the digital input "Enable control" (refer to section "Digital inputs" ^[13]) and in the operating mode "Remote PASO" through the command "Enable" (refer to section "Commands_Disable / Enable" ^[72]).

4.5 Operating mode

The SD6-Electronics have 2 operating modes. The following table describes, what can be done in the different operating modes and how they can be activated:

Operating mode	Activating with	Description
Local	Menu point "Commands_Local Operating"	Operating via analogue and digital inputs on the SD6-Electronics
Remote PASO	Menu point "Commands_PASO Operating"	Operating direct with the PASO

The current operating mode is displayed in the status line (refer to section ["Starting of PASO DSV/SD6"](#)^[86]). For more information about the operating mode "Local" and "Remote", please refer to section ["Commands_Local Operating / PASO"](#)^[72].

4.6 Analogue inputs

- The applied analogue signal is digitised in the 10Bit A/D converter at analogue inputs 1 and 2 resp. in the 16Bit A/D converter at analogue inputs 3 or 4.

Attention: By the input range 4 ... 20mA, the resolution is < 10Bit resp. < 16Bit!

- Differential inputs**

All analogue inputs are differential inputs. Differential inputs are used if the ground potential of the external command value generator does not agree with the ground on the SD6-Electronics.

If the differential input is intended to use like an analogue input against ground, the - (minus) connection of the differential input must be connected to the ground of the SD6-Electronics. In this case please attend that the solenoid current can cause a voltage drop between the SD6-Electronics and the power supply. It is recommended to connect the - (minus) connection as near as possible to the power supply.

SD6-Type	Analogue input 1 (10-bit resolution)	Analogue input 2 (10-bit resolution)	Analogue input 3 (16-bit resolution)	Analogue input 4 (16-bit resolution)
SD6362DX4-BX	0...10VDC 0...±10VDC (only with 2-sol control modes)	0...20mA, 4...20mA	0...10VDC 0...±10VDC (only with 2-sol control modes)	0...20mA, 4...20mA
SD6362DX5-BX	0...10VDC 0...±10VDC (only with 2-sol control modes)	0...10VDC 0...±10VDC ** (only with 2-sol control modes)	0...10VDC 0...±10VDC (only with 2-sol control modes)	0...10VDC 0...±10VDC (only with 2-sol control modes)
SD6362DX6-BX	0...20mA, 4...20mA	0...20mA, 4...20mA	0...20mA, 4...20mA	0...20mA, 4...20mA
SD6362DX7-BX	0...10VDC 0...±10VDC (only with 2-sol control modes)	0...10VDC 0...±10VDC ** (only with 2-sol control modes)	0...20mA, 4...20mA	0...20mA, 4...20mA
SD6362DX8-BX	0...20mA, 4...20mA	0...20mA, 4...20mA	0...10VDC 0...±10VDC (only with 2-sol control modes)	0...10VDC 0...±10VDC (only with 2-sol control modes)

**) 0...+10VDC on SD6 with Profibus

4.7 Cablebreak detection

The analogue inputs with input signal range of 4...20mA can be detected for a cablebreak. If a cablebreak is present (input signal less than 3mA), the corresponding solenoid outputs will be blocked and the output "Error" will be active. The following conditions had to be performed:

- The input signal must be a current value 4 ... 20mA
- The parameter "Cablebreak" must be on "On"



Attention: Until a cablebreak will be detected, a time delay of about 100ms will pass. During this time, the cylinder can make unintentional movements or unintentional force changes.

4.8 Digital inputs

- **Digital input 1 "Enable control"**
The digital input is active-high (refer to section ["Electrical specifications"](#)^[54]).
If this input is set, the SD6-Electronics are enabled. Without this enable, no solenoid current will be output.
This digital input can be set also through the parameterisation software PASO DSV/SD6 (refer to section ["Configuration Digital I/O"](#)^[65]).
- **Digital input 2 "Automatic / Manual operation"**
At **manual operation** (digital input low) the command value is being generated by digital inputs 3...5. For this two velocities are available in both directions.
At **automatic operation** (digital input high) the command value is being generated by the profile generator or read from an analog input, depending on the state of the digital inputs 3...8.
To switch between manual and automatic operation, the SD6 has to be disabled by deactivating digital input 1.
- **Digital input 3 "Manual forward" or "Profile / Sequence"**
Manual operation: When the digital input is activated the command value will be incremented. The velocity depends on digital input 5 "Rapid speed / Creep speed".
Automatic operation: Choice between running through a complete profile (digital input high) or an individual sequence (digital input low).
- **Digital input 4 "Manual reverse" or "Start"**
Manual operation: When the digital input is activated the command value will be decremented. The velocity depends on digital input 5 "Rapid speed / Creep speed".
Automatic operation: Depending on digital input 3 "Profile / Sequence" the running through of the complete profile or of the next sequence only is started.
- **Digital input 5 "Rapid speed / Creep speed" or "Stop"**
Manual operation: Changeover between rapid speed (digital input high) and creep speed (digital input low).
Automatic operation: As long as the digital input is high the axis can move. As soon as the digital input becomes low the movement is stopped (set-point value = feedback value).
- **Digital input 6...8 "Profile selection"**
These digital inputs only take effect in **automatic operation**. Profiles can only be used in closed loop control modes (an exception is the pQ-control mode, where no profiles can be used). How to select the profiles is shown in the table below. If profile 0 is selected the command value will be read from one of the analogue input. A detailed description of the profiles is located in the section ["Profile-Menu"](#)^[37]

Digital input 6	Digital input 7	Digital input 8	Profile
0	0	0	* 0 (analogue command value)
1	0	0	1
0	1	0	2
1	1	0	3
0	0	1	4
1	0	1	5
0	1	1	6
1	1	1	7

* with control mode "Alternating control (2-sol)" the analogue command value will not read if profile selection is 0. In this case, the command value will be set to the actual value (= axis remains controlled at the actual position). Should be used an analogue command value, the corresponding signal type must be selected (refer to section "[Configuration_Signal Scaling](#)"⁵³).

4.9 Input for digital sensor

This input makes it possible to connect digital sensors with SSI- or Start/Stop-Interface.

SSI-Interface

SSI-Interface according RS-422 standard with a baudrate of 300kHz.

Start/Stop-Interface

This Interface supports sensors with a Start/Stop-Interface as they are available e.g. from Balluff or MTS.

Init-Impuls from the SD6 electronics

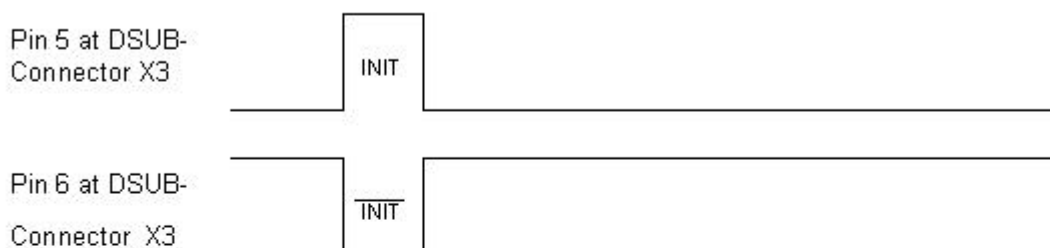

Start- and Stop-Impuls from the sensor

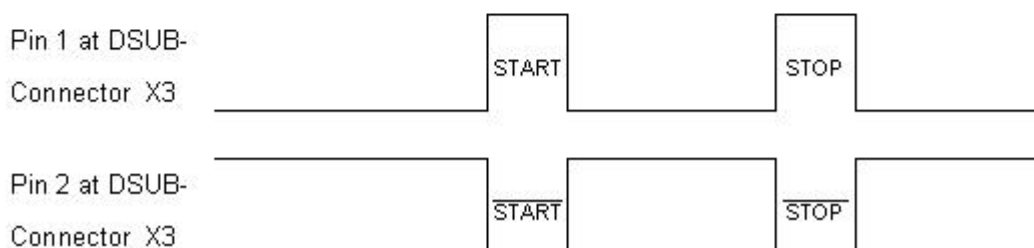

4.10 Outputs

- **Proportional solenoid outputs A and B**

The max. 2 solenoid outputs have a current output with 1000 Hz **Pulse-Width-Modulation** with superimposed dither.

- **Analog output**

The analog output can be assigned to the following signals via the PASO DSV/SD6 (depending on the control mode, different signals are available):

- command value for the solenoid driver
- scaled command value
- scaled feedback value (only with closed loop control modes)
- scaled control deviation (only with closed loop control modes)

The signal at the analog output can be used for driving a valve with integrated electronics which has a voltage interface. The output level can be adjusted (refer to section ["Configuration Analog output"](#)^[65]).

- **Digital outputs**

The following digital outputs are available:

- Digital output 1 "Error"
- Digital output 2 "Solenoid B active", "Inside target window / End of Seq"
- Digital output 3 "Trailing error"
- Digital output 4 "Profile End reached"

The digital output can be configured by the PASO DSV/SD6 Software (refer to section ["Configuration Digital I/O"](#)^[65]).

4.11 Controller Modes

The SD6-Electronics provide the following controller modes:

- **Controller mode 3 "Pressure/flow valve open loop"**

Control of a pressure relief-, pressure reducing- or flow control valve in open loop (without feedback signal). The number of solenoids, which are activated, depends on the selected mode of operation (refer to section ["Mode of operation"](#)^[52]).

This mode of operation corresponds to the "Device Control Mode = 3" of the fieldbus device profile Fluid Power Technology.

- **Controller mode 4 "Pressure/flow valve closed loop (1-sol)"**

Control of a 1-solenoid pressure relief-, pressure reducing- or flow control valve in closed loop (with feedback signal). It can only be activated one solenoid (correspond to solenoid driver 1).

In this controller mode, the parameter "Mode of operation" has no meaning (refer to section ["Mode of Operation"](#) ^[52]).

This mode of operation corresponds to the "Device Control Mode = 4" of the fieldbus device profile Fluid Power Technology.

Example Application:

Pressure Control: with one proportional pressure relief valve, the pressure p is held constant to the command pressure value w .

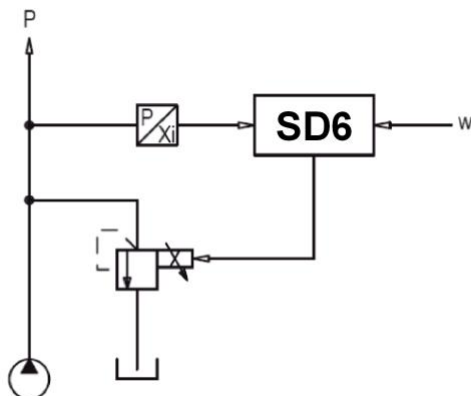

Example Application: Flow Control: with one proportional throttle valve, the flow Q is held constant to the flow command value w .

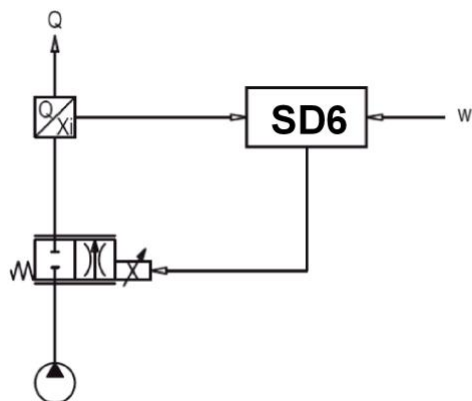

- **Controller mode 6 "Position open loop"**

Control of a spool valve in open loop (without feedback signal).

The number of solenoids, which are activated, depends on the selected mode of operation (refer to section ["Mode of operation"](#) ^[52]).

This mode of operation corresponds to the "Device Control Mode = 6" of the fieldbus device profile Fluid Power Technology.

- **Controller mode 7 "Speed control closed loop (2-sol)"**

Control of a 2-solenoid pressure relief-, pressure reducing- or flow control valve in closed loop (with feedback signal). It can be activated two solenoids.

In this controller mode, the parameter "Mode of operation" has no meaning (refer to section ["Mode of Operation"](#) ⁵²).

This mode of operation corresponds to the "Device Control Mode = 7" of the fieldbus device profile Fluid Power Technology.

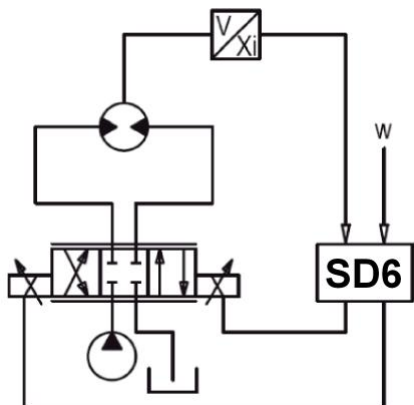

- **Controller mode 9 "Position closed loop"**

Control of a 2-solenoid spool valve in closed loop (with feedback signal). It can be activated two solenoids.

In this controller mode, the parameter "Mode of operation" has no meaning (refer to section ["Mode of Operation"](#) ⁵²).

This mode of operation corresponds to the "Device Control Mode = 9" of the fieldbus device profile Fluid Power Technology.

Example application: with a 4/3-proportional-spool valve, the axis position is held constant to the command position value w..

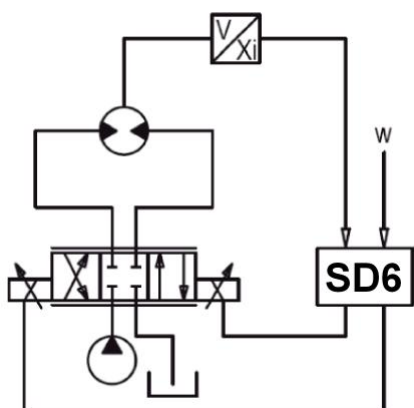

- **Controller mode -5 "Pressure control closed loop (2-sol)"**

Control of two 1-solenoid throttle valves in closed loop (with feedback signal) as a pressure reducing system. One throttle valve is the loading valve, the other throttle valve is the unloading valve. The loading valve corresponds to solenoid driver 1, the unloading valve to the solenoid driver 2.

In this controller mode, the parameter "Mode of operation" has no meaning (refer to section ["Mode of Operation"](#) ⁵²).

This controller mode is a WANDFLUH specific controller mode and does not correspond to the fieldbus device profile Fluid Power Technology.

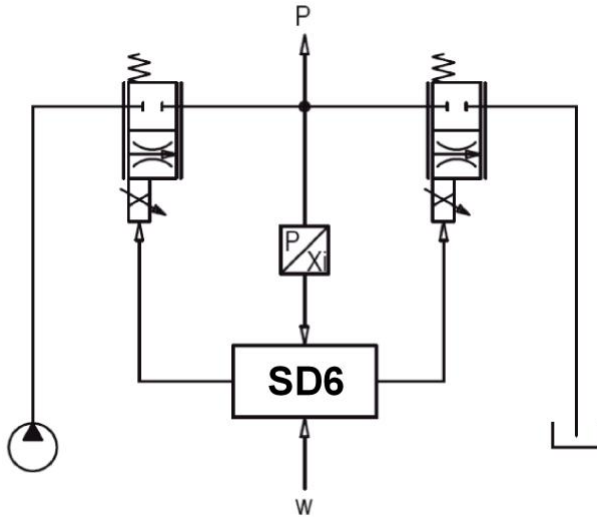

This setting is available only with a SD6-electronics with software version > 1.1.1.6 and PASO with software version > 1.5.0.9!

• **Controller mode –9 "pQ control (2-sol)"**

Driving of a direction control valve in open loop control circuit (without feedback signal) with monitoring of a predefined pressure (with feedback signal).

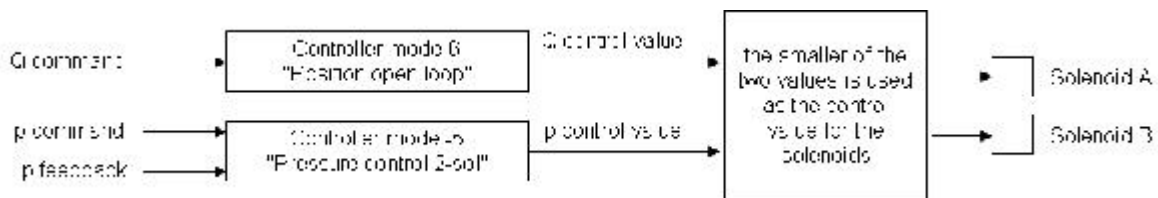

There is a Q and a p command value. With the Q command value, the cylinder can move in open loop in both directions. The p command value defines the maximum allowed pressure. If this pressure is exceeded, the controller reduces the output signal to the valve. In this case the preset pressure is not exceeded. A rear dodge (cylinder moves backward) is possible. The p feedback value can be either an absolute signal (V or mA) from a pressure or force sensor or can be built as a differential signal from two pressure or force sensors (V or mA).

With this controller mode, the choice of the proportional valve has a high influence on the system behavior. More details about it are available from factory.

Example application: with a 4/3-proportional-spool valve, the axis will move in open loop (without feedback signal). Simultaneously the pressure is monitored (measured with the pressure sensor).

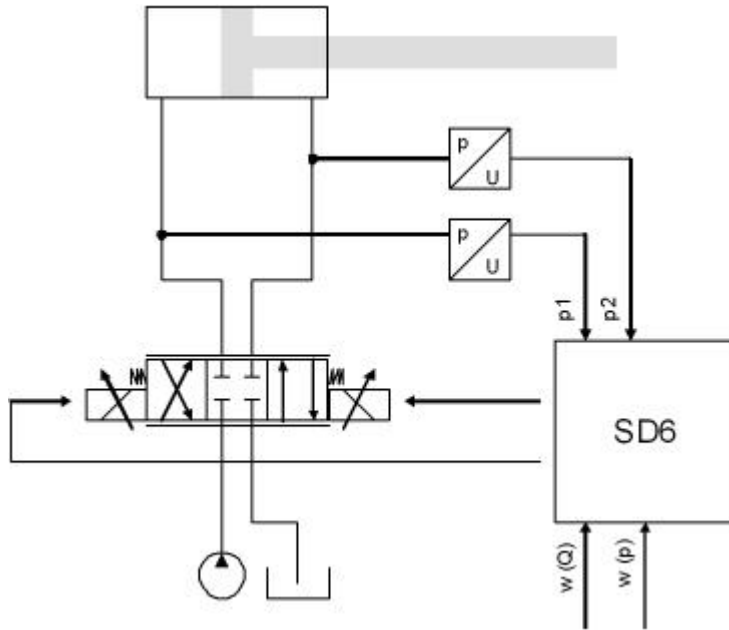

This setting is available only with a SD6-electronics with software version higher than 1.1.3.0 and PASO with software version higher than 1.5.1.2!

• **Controller mode –10 "Alternating control (2-sol)"**

Driving of a direction control valve in closed loop control circuit (with feedback value return) with monitoring of a predefined pressure (with feedback value return).

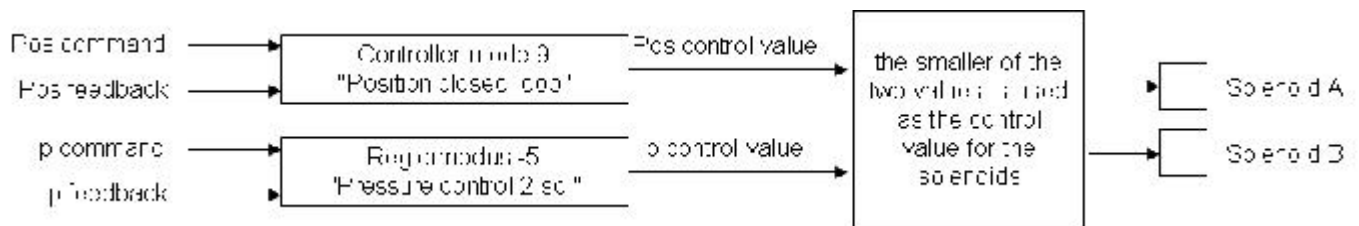

There is a pos and a p command value. With the pos command value, the cylinder can move in closed loop in both directions. The p command value defines the maximum allowed pressure. If this pressure is exceeded, the position controller is switched off and the controller reduces the output signal to the valve. In this case the preset pressure is not exceeded. If the actual pressure is smaller than the p command value, the position controller is switched on. A rear dodge (cylinder moves backward) is possible. The p feedback value can be either an absolute signal (V or mA) from a pressure or force sensor or can be built as a differential signal from two pressure or force sensors (V or mA).

With this controller mode, the choice of the proportional valve has a high influence on the system behavior. More details about it are available from factory.

Example application: with a 4/3-proportional-spool valve, the axis position is held constant to the command position value w. Simultaneously the pressure is monitored (measured with the pressure sensor).

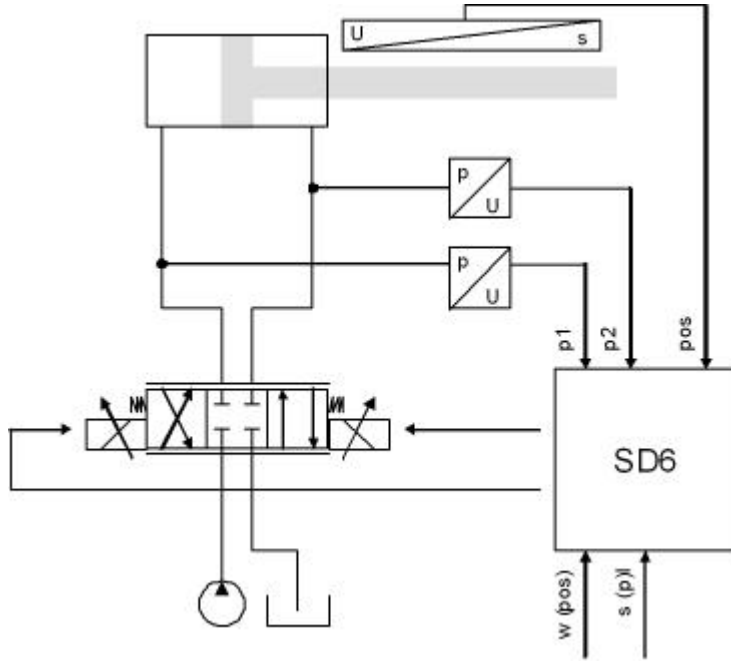

This setting is available only with a SD6-electronics with software version higher than 1.1.3.0 and PASO with software version higher than 1.5.1.2!

4.12 Mode of operation

The mode of operation is only of significance in controller mode "Pressure/flow valve open loop", "Position open loop" and "pQ control (2-sol)". In all other controller modes the mode of operation is not taken into consideration. The following 4 modes of operation are possible:

- **Mode of operation 1 "Command value unipolar (1-solenoid)"**

This mode of operation is only selectable with the 1-solenoid version.

With an analogue input (voltage or current) with a 1-solenoid valve the solenoid A is driven.

0% ... 100% command value = I_{min} ... I_{max} solenoid A

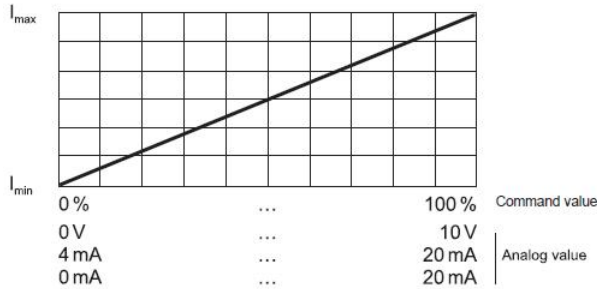

- **Mode of operation 2 "Command value unipolar (2-solenoid)"**

This mode of operation is only selectable with the 2-solenoid version.

With an analogue input (voltage or current) with a directional control valve, solenoid A and solenoid B are driven.

0% ... 50% command value = I_{max} ... I_{min} solenoid B

50% ... 100% command = I_{min} ... I_{max} solenoid A
value

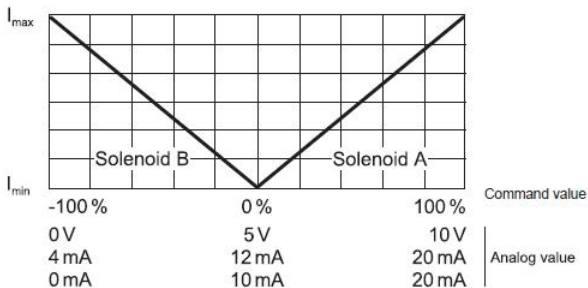

- **Mode of operation 3 "Command value bipolar (2-solenoid)"**

This mode of operation is only selectable with the 2-solenoid version.

With an analogue input (voltage) of 0 ... $\pm 10V$ with a directional control valve, solenoid A (positive voltage) and solenoid B (negative voltage) are driven.

-100% ... 0% command value = I_{max} ... I_{min} solenoid B

0% ... 100% command = I_{min} ... I_{max} solenoid A
value

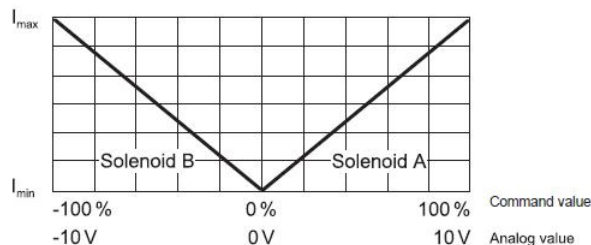

- **Mode of operation 5 "Command value unipolar (2-solenoid)"**

This mode of operation is only selectable with the 2-solenoid version.

With an analogue input (voltage or current) with a directional control valve, depending on the digital input 2, solenoid A or solenoid B is driven.

Digital input 2 "low":

0% ... 100% command= I_{min} ... I_{max} solenoid A
 value,

Digital input 2 "high":

0% ... 100% command= I_{min} ... I_{max} solenoid B
 value,

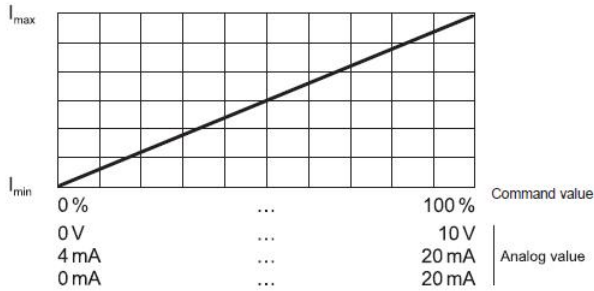

5 Operating and Indicating elements

5.1 General

All inputs and outputs have to be contacted through the terminal screw blocks. On the front panel of the electronic housing, there is a USB interface, through which the parameterisation and the diagnostics can be made by using the PC-Parameterisation software PASO DSV/SD6.

5.2 Screw terminator view

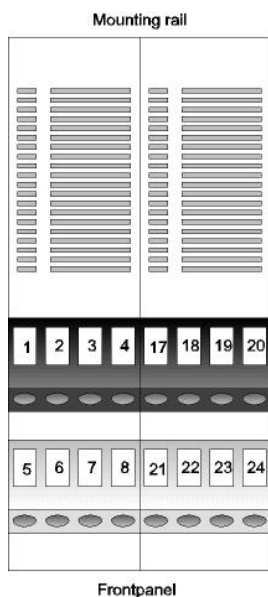

X1-1 = Digital input1
 X1-2 = Digital input 2
 X1-3 = Digital output 1
 X1-4 = Digital output 2
 X1-5 = Supply voltage +
 X1-6 = Supply voltage 0 VDC
 X1-7 = Stabilised output voltage
 X1-8 = Analogue ground
 X1-17 = Digital input 3
 X1-18 = Digital input 4
 X1-19 = Digital input 5
 X1-20 = Digital input 6
 X1-21 = Digital input 7
 X1-22 = Digital input 8
 X1-23 = Digital output 3
 X1-24 = Digital output 4

Top view of box

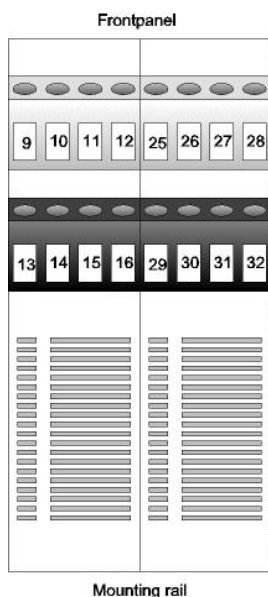

X1-9 = Analogue input 1 +
 X1-10 = Analogue input 1 -
 X1-11 = Analogue input 2 +
 X1-12 = Analogue input 2 -
 X1-13 = Output Solenoid B +
 X1-14 = Output Solenoid B -
 X1-15 = Output Solenoid A +
 X1-16 = Output Solenoid A -
 X1-25 = Analogue input 3 +
 X1-26 = Analogue input 3 -
 X1-27 = Analogue input 4 +
 X1-28 = Analogue input 4 -
 X1-29 = Digital ground
 X1-30 = Analogue ground
 X1-31 = Stabilized output voltage
 X1-32 = Analogue output

Bottom view of box

5.3 Control elements

5.3.1 General

The front panel of the SD6-Electronics contains the connector to the USB-Interface. Additionally the front panel is provided with three LED's, which inform the user about the device functioning.

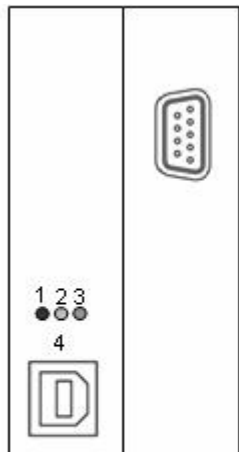

- 1: ERROR-LED red
- 2: FUNCTION-LED yellow
- 3: SUPPLY-LED green
- 4: USB-Interface

Front panel view

5.3.2 ERROR-LED (red)

The ERROR-LED displays, when an error is detected (refer to section ["The system does not work"](#) ⁽⁸⁰⁾).

5.3.3 FUNCTION-LED (yellow)

In the controller modes "Pressure/flow valve open loop" and "Position open loop" the FUNCTION-LED is lighting as soon as a solenoid current is forced (solenoid A and/or solenoid B).

In the controller modes "Pressure/flow valve closed loop", "Speed control closed loop", "Position closed loop" and "Pressure control closed loop" the FUNCTION-LED is lighting when the target window is reached.

In the controller modes "pQ-control" and "Alternating control" the FUNCTION-LED is lighting depending on the state of the digital output 2 (refer to section ["Configuration Digital I/O"](#) ⁽⁶⁵⁾).

5.3.4 SUPPLY-LED (green)

The SUPPLY-LED is lighting, when the SD6-electronics are supplied.

5.3.5 USB-interface

The USB-interface allows the parameterisation and the analysis of the SD6-electronics by PASO software. The connection to the PC is realised by standard USB-cables (USB Type A connector PC-side, USB Type B connector SD6-side).

View of the USB-interface:

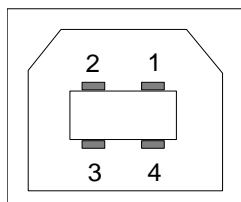

Connector USB Type B

X2-1 = VBUS
X2-2 = D-
X2-3 = D+
X2-4 = GND

Hint: The USB-cable is not included.

6 Commissioning

Please refer to section "[Safety rules](#)" ^[9].

6.1 Connection instructions

The contact assignment of the following description refers to section "[Operating and Indicating elements](#)" ^[23] and to section "[Connection examples](#)" ^[28].

For an **installation / connection appropriate for EMC**, the following points absolutely have to be observed:

- Cable length longer than 10m requires shielded cables. The shield of the cable must only be connected with the earthing on the switchboard side using a large surface area and low Ohm connection.
- The top-hat rail has to be connected with the earthing with an as short as possible conductor with a strand cross section $\geq 1.5 \text{ mm}^2$.
- Solenoid- and signal cables must not be laid parallel to high voltage cables.

6.1.1 Supply voltage

- For the dimensioning of the power supply, the maximum current demand of the solenoids (in case of directional control valves only the maximum current demand of 1 solenoid) has to be increased by the no load current from the SD6-Electronics (refer to section "[Electrical specifications](#)" ^[5]).
- The limit values of the supply voltage and its residual ripple indispensably have to be complied with (refer to section "[Electrical specifications](#)" ^[5]).
- The SD6-Electronics have to be protected with a slow acting fuse

6.1.2 Digital inputs and outputs

- The digital inputs are active-high and not galvanically separated
- For activation, they have to be connected to a voltage between 6 ... 30VDC (e.g. power supply)

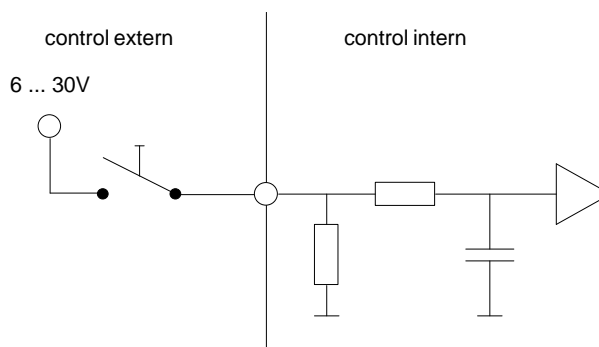

- The digital outputs are "Lowside Switch" outputs (open collector)

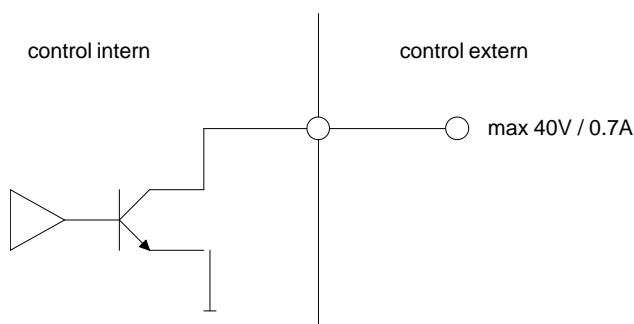

6.1.3 Analogue inputs 10-Bit and 16-Bit

- Depending on the card type current and / or voltage inputs with 10-bit or possibly with 16-bit resolution are available (refer to section "[Electrical specifications](#)" and "[Analogue inputs](#)")
- All inputs are differential inputs.

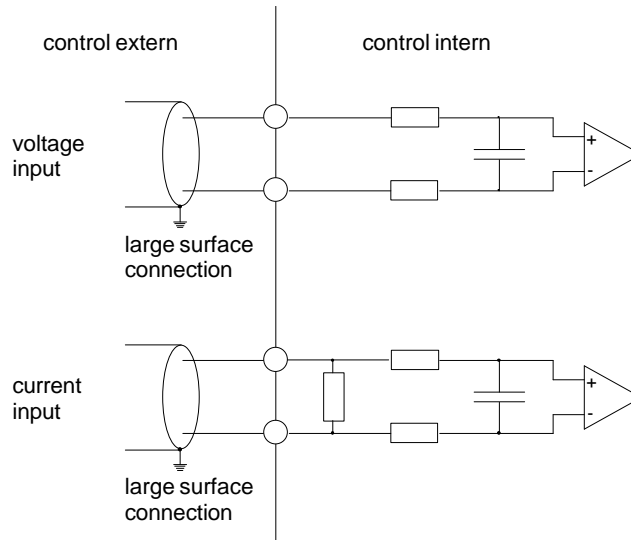

6.1.4 Configuration of the analogue inputs 10-Bit and 16-Bit

The analogue inputs can be configured as follows:

Input signal	Pin configuration screw terminators	Input range
Voltage against ground	10-Bit (example with Analnp1): + at Pin X1-9 / Pin X1-10 at ground	0 ... +10V 0 ... ±10V
	16-Bit (example with Analnp3): + at Pin X1-25 / Pin X1-26 at ground	
Differential voltage	10-Bit (example with Analnp1): + at Pin X1-9 / - at Pin X1-10	0 ... +10V 0 ... ±10V
	16-Bit (example with Analnp3): + at Pin X1-25 / - at Pin X1-26	
Current against ground	10-Bit (example with Analnp2): + at Pin X1-11 / Pin X1-12 at ground	0 ... 20mA 4 ... 20mA
	16-Bit (example with Analnp4): + at Pin X1-27 / Pin X1-28 at ground	
Differential current	10-Bit (example with Analnp2): + at Pin X1-11 / - at Pin X1-12	0 ... 20mA 4 ... 20mA
	16-Bit (example with Analnp4): + at Pin X1-27 / - at Pin X1-28	

6.1.5 Digital Sensor

This interface for digital sensors works as RS-422 standard (refer to section ["Input for digital sensor"](#) ²⁸)

Pin assignment:

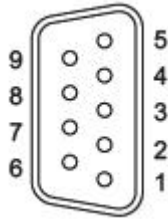

- X3-1 = Digital input + / Data +
- X3-2 = Digital input - / Data -
- X3-3 = Reserved
- X3-4 = Reserved
- X3-5 = Clock output + / Clock +
- X3-6 = Clock output - / Clock -
- X3-7 = Output +5VDC
- X3-8 = Sensor-ground
- X3-9 = Output +24VDC

6.2 Connection examples

The contact assignment of the following description refers to section ["Operating and Indicating elements"](#) ²³.

6.2.1 Position Control

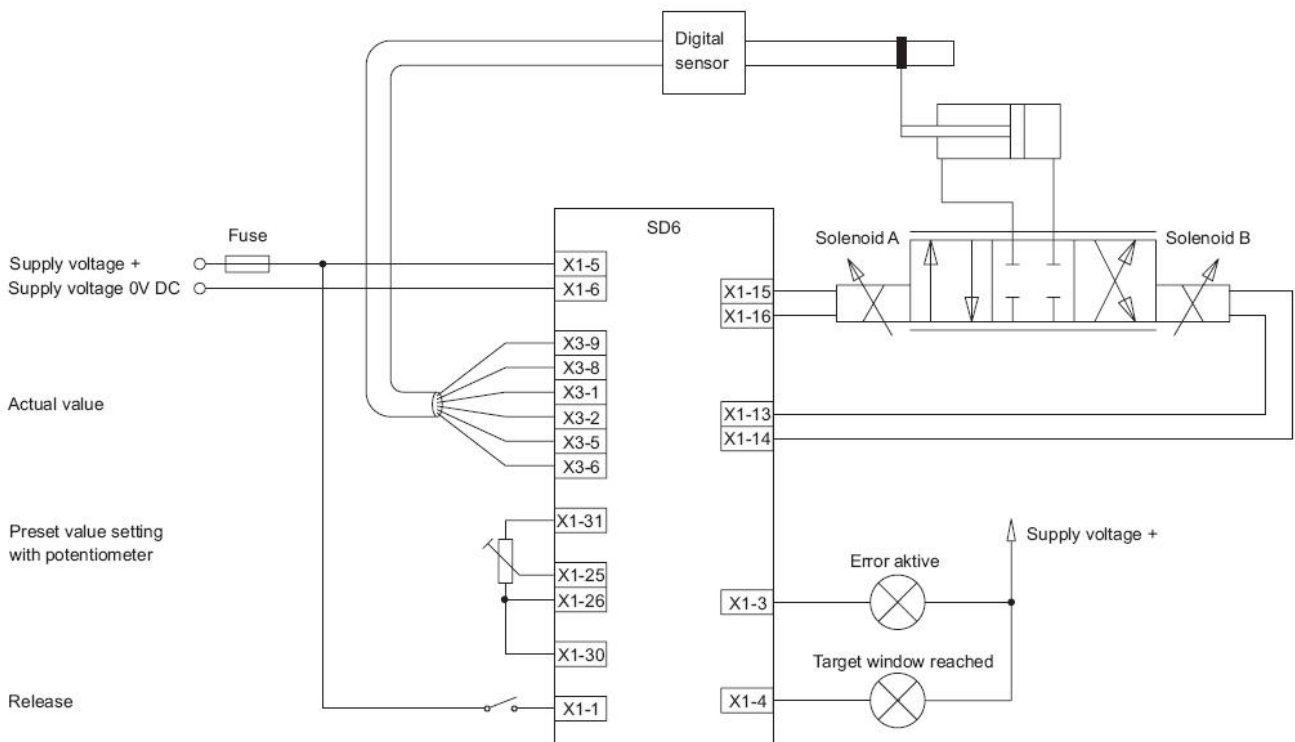

7 Settings

Please refer to section ["Safety Rules"](#) ⁹.

7.1 Introduction

- The system- and parameter settings can be made via the RS232 interface with the PC-Parameterisation software PASO DSV/SD6.
- For information about the operation via the PC-Parameterisation software PASO DSV/SD6 please refer to section "PASO DSV/SD6 Installation and Operation".
- Depending on the connected SD6-Electronics, certain settings may be blocked.

7.2 Tips for the first commissioning

- Connect the power supply, leave the SD6-Electronics still switched-off.
- Switch-off the hydraulic drive (hydraulics switched-off).
- Carefully check the connections.
- Switch-on the power supply.
- Establish communication with PASO (connect PC and axis controller with a standard USB cable and start PASO).
- Configure the SD6-Electronics specific to the installation. In doing so, the following sequence should be observed:
 1. Make the corresponding settings in the menu "[Configuration Controller mode](#)" ⁵²
 2. Select the corresponding mode of operation In the menu "[Configuration Mode of operation](#)" ⁵² (only with open loop controller modes)
 3. make the corresponding settings in the menu "[Configuration Signal scaling](#)" ⁵³
- Switch-on the hydraulics.
- For the card to be enabled, the digital input "Enable Control" has to be set (refer to section "[Digital Input](#)" ⁶⁵).
- Corresponding to the set-point value command, the axis should now run up to the required position. If the axis only runs up to the mechanical stop in one direction, then the system control sense is probably wrong (change it in the menu point "[Configuration Controller mode](#)" ⁵²).
- The command value direction (e.g., potentiometer left/right) should correspond to the axis direction. If not, either change the set-point value direction or the feedback value direction (change in the menu point "[Configuration Signal scaling](#)" ⁵³). If the feedback value direction is reversed, then simultaneously the connection of the solenoids 1 and 2 have to be switched.
- Set the drive currents of the valves in the menu "[Parameter Valves](#)" ⁴³.
- Set the control parameters in the menu "[Parameter Controller](#)" ⁴⁸.
- Make the settings in the menu "[Parameter Window](#)" ⁵⁰.

7.3 Start up help

The following description is intended as a guide for the setting of a control system. It is important that the default order is maintained. The value of each parameter is always system dependent. Larger deviations in the setting can occur quite of different systems.

Start up Position controller

- The parameter 'Imin A' resp. 'Imin B' should be set in the way that the axis just slightly move
- The parameter 'Imax A' resp. 'Imax B' should be set in the way that the max. desired speed is reached at the axis
- Adjust the desired value for the [target window](#) ^[50] (control deviation < target window threshold = target window reached)
- Adjust the desired value for the [trailing error](#) ^[50] window (control deviation > trailing error window threshold = trailing error)
- Adjust the desired value for the [solenoid-off window](#) ^[50] (control deviation < solenoid off window threshold = solenoids are switched off)
Please note therefore the following:
 - The solenoid off function is only active, if the parameter 'Solenoid In position' in the menu '[Configuration - Control mode](#)' ^[52] is set to 'off'. If it sets to 'on', the solenoid are never switched off
 - If the value for the parameter 'Solenoid off threshold' is higher than the value for the parameter 'Target window threshold', then the target window will never be reached (the solenoids are switched off before the target position is reached)
- Using the parameters of the [PID controller](#) ^[48], the control behavior can be adjusted
- Because a position control is a dynamic control system, it can be waived to the I-term in many cases
- First, the P-term should be set
- Therefore increase gradually the parameter 'P-Ampl' until the desired response time is reached, without the system oscillates
- If necessary, the running in the final position can be changed with the I-term
- With the parameter 'Velocity feed forward', the riding of the cylinder can be accelerated. The change of the command value (the increase speed of the command value) is multiplied with this factor and added to the correcting variable of the controller. If this factor is 0, no command value addition is added to the correcting variable
- The parameter 'Command feed forward' should be set to 0 in this control mode

Start up Pressure controller

- Set all [controller parameters](#) ^[48] (P-Ampl, I-Window, I-Time, D-Ampl and D-Time, at a time positive and negative) to 0
- Set parameter 'Command feed forward' to 1.0
- Change the preset value from min to max. The actual value should follow with a difference
- Change the value from the parameter 'Command feed forward' in the case that the difference between preset and actual value is as small as possible. The difference is not the same over the whole range. Select the smallest difference in the range, where the system will work mostly
- Increase the value from the parameter 'P-Ampl'. As long as the system does not start to swing, this parameter can be increased
- Find out the highest control deviation (with the Menu '[Analysis - Signal recording](#)' ^[76])
- The highest control deviation plus 10 bar will be the value for the parameter 'I-Window outside'
- Set parameter 'I-Window Inside' to 1 bar
- Set parameter 'I-Time' to 1 s. If the system is not fast enough, decrease the value from 'I-time'

Start up pQ-controller and Alternating controller

- First, set the parameter for the position controller analog to the start up position controller (set [Setup mode](#) [73] to 'Position')
- Afterwards, set the parameter for the pressure controller analog to the start up pressure controller (set [Setup mode](#) [73] to 'Pressure')
- Please note therefore the following:
 - The [Dithersignal](#) [43] must be active resp. set high enough (lower frequency / higher level)
Therefore the adjusted values for Imin A resp. Imin B are also correct for the pressure controller
 - The smaller of the two control values is active. A "stronger" controller loses out to a "weaker" controller.
With a corresponding adjustment it is possible to prioritize the position or pressure controller (e.g. performs a fast integral to a higher control value and loses against the 'weak regulator')
 - Set parameter "[I-term, if control deviation > I-Window outside](#)" [48] to "leave value"
 - Set parameter "[I-term, if controller is not active](#)" [48] to "leave value"
 - Set parameter '[Command feed forward](#)' [48] to 0
 - The feedback pressure signal should be read as a differential pressure with two sensors (there can be a problem with starting the movement with one sensor)
- With a double acting cylinder, the pressure feedback value should read in as a differential pressure with two pressure sensor
- With a single acting cylinder, the pressure feedback value can read in also with only one pressure sensor.
This should be installed on the working side (active side).
- Instead of a pressure sensor also a force sensor can be used
- A 4/3-way spool valve with central position A-B-T connected (valve type ...-ADB-...) is not suitable

7.4 Default settings

In the factory, the SD6-Electronics will be set to the following default values:

Parameter	Werkseinstellung
Reglermodus	Achsposition gesteuert
Ausgang Magnet A	Strom nicht invertiert
Ausgang Magnet B	Strom nicht invertiert
Imin immer aktiv	nein
Systemregelsinn	nicht invertiert
Magnet 'In Position'	ein
Betriebsart	Sollwert unipolar (2-Mag)
Signaltyp Sollwert	0...10V
Benutzer Eingang Sollwert	Analogeingang 1
Invertierung Sollwert	nein
Kabelbruch-Überwachung Sollwert	nein
Skalierung Sollwert	20.000 %/V
Offset Sollwert	0.00 V
Min. Interface Sollwert	0.000 V
Max. Interface Sollwert	10.000 V
Min. Reference Sollwert	0.0 mm
Max. Reference Sollwert	100.0 mm
Signaltyp Istwert	0...10 V
Benutzer Eingang Istwert	Analogeingang 3
Kabelbruch-Überwachung Istwert	nein
Min. Interface Istwert	0.000 V
Max. Interface Istwert	10.000 V
Min. Reference Istwert	0.0 mm
Max. Reference Istwert	100.0 mm
Offset Istwert	0.00 mm
Auflösung Istwert	0.005 mm/Inc
Max. Reference digitales Messsystem	100.00 mm
Bit Anzahl SSI	24
v-Ausbreitung Istwert	2850880 mm/s
Anzeige Einheit	mm
Totband	0.0 %
IminA	150 mA
ImaxA	700 mA
IminB	150 mA
ImaxB	700 mA
Min. Interface Analogausgang	-10.00V
Max. Interface Analogausgang	10.00V
Rampe A auf	0.00 s
Rampe A ab	0.00 s
Rampe B auf	0.00 s
Rampe B ab	0.00 s
Geschwindigkeit +	1000 mm/s

Parameter	Werkseinstellung
Geschwindigkeit -	1000 mm/s
Eilgang	500 mm/s
Schleichgang	100 mm/s
Ditherfrequenz	100 Hz
Ditherpegel	100 mA
Sollwertaufschaltung	0.00
Geschwindigkeitsaufschaltung	0.000
Regeldifferenz, wenn I-Anteil > I-Fenster Aussen	auf 0 setzen
P-Vestärkung positiv	5.0
I-Zeit positiv	0.100
I-Fenster Aussen positiv	5.00
I-Fenster Innen positiv	0.00
D-Zeit positiv	0.000
D-Verstärkung positiv	0.0
P-Vestärkung negativ	5.0
I-Zeit negativ	0.100
I-Fenster Aussen negativ	5.00
I-Fenster Innen negativ	0.00
D-Zeit negativ	0.000
D-Verstärkung negativ	0.0
Ziel Fenster Schwelle	10.00 mm
Ziel Fenster Verzögerungszeit	50 ms
Schleppfehler Fenster	10.00 mm
Schleppfehler Verzögerungszeit	50 ms
Magnet-Aus Fenster Schwelle	10.00 mm
Magnet-Aus Fenster Verzögerungszeit	50 ms

In the sections ["Parameters - Menu"](#)^[43] and ["Configurations - Menu"](#)^[52] you will find detailed descriptions of each of these parameters.

7.5 File-Menu

Contained in the File menu are the menu points, which concern the file handling and the printing of the parameters. In the "On Line"-mode, some of these menu points are blocked.

7.5.1 File_New

This menu point is active only in the "Off Line"-mode.

With this command, a new file can be opened. Near it, all parameters are set to default values. A question will be displayed, if the current configuration will be retain or not.

If "Yes" will be selected, the current configuration will not be changed.

If "No" will be selected, a selection window will be displayed. In this window, the following configuration can be selected.

Function	<ul style="list-style-type: none"> • Amplifier • Amplifier with manual operation • Amplifier with fixed command values • Basic Controller • Enhanced Controller
Analogoutputs	<ul style="list-style-type: none"> • Input 1 voltage or current • Input 2 voltage or current • Input 2 current only if Function = Enhanced Controller • Input 3 voltage or current • Input 4 voltage or current
Number of solenoids	<ul style="list-style-type: none"> • 1-Solenoid • 2-Solenoid
Mode of operation	<ul style="list-style-type: none"> • without mode of operation 'Solenoid single' (only if Function = Amplifier) • with mode of operation 'Solenoid single' (only if Function = Amplifier)
Fieldbus	<ul style="list-style-type: none"> • without Fieldbus • with Profibus DP (only if Function = Amplifier, Basic Controller or Enhanced Controller)

The modified configuration only affects the "Off Line"-mode. By switching to "On Line"-mode the configuration of the connected SD6-electronics will be read in.

7.5.2 File_Open

This menu point is only active in the "Off Line"-mode.

With this command, an existing file from a storage medium is opened. First the file selection window appears. In this window the required file can now be selected and opened with "OK". If the configuration of the selected file does not correspond to the current configuration of the PASO DSV/SD6, a message will be displayed and the current configuration from the PASO DSV/SD6 will change automatically over to the new configuration of the selected file. The read parameter values will be checked in the case of a limiting value excess. If one or more parameter values are outside the tolerance, a message will be displayed and the parameter value will be set to the default value (refer to section ["Limiting value error"](#)^[87]). The parameter values can now be edited and changed as required under the corresponding menu points.

7.5.3 File_Save

With this command, the parameters are saved on a data storage medium. All parameter values of all input windows are saved under the current file name. If no file name has been defined yet, then first the file selection window appears (refer to section ["File Save as..."](#)^[35]).

7.5.4 File_Save as

With this command, the parameters are saved on a data storage medium. All parameter values of all input windows are saved under the file name entered.

First the file selection window appears. In this window the desired file name can now be entered. If the file name is entered without an extension, then the extension ".par" is automatically assigned to it. After actuating the key "Save", the file information window appears (refer to section "[File-Info](#)"^[35]). In this window the required entries can now be made. With the key "Save", the file is then finally saved under the selected file name. With the key "Cancel", one changes back to the file window.

7.5.5 File_Print

With this command, the current parameters are printed in ASCII text format. The File_Print window is opened. In this window one can now select, whether the printing process is to be to a printer or to a file.

If the output is to be to a printer, then the Windows printer selection window is opened. **In this window, please do not select "Print to File"**. If you do, a new program start might possibly be required and you could lose any data not yet saved.

If the output is to be to a file, then the file selection window appears. In this window the desired file name can now be entered. If the file name is entered without an extension, then automatically the extension ".txt" is assigned to it.

7.5.6 File_Info

With this command, the file information of an existing file is displayed. The file information consists of the following parts:

Date, time Date, time of saving.

File name: The file name, under which the file has been saved.

Valve type: The valve type of the connected SD6-Electronics at the moment of saving. If no SD6-Electronics are connected, then this indication remains empty. In case of saving during "On Line Operation", this indication is updated.

Operator: The name of the originating person.

Remarks: Possibility to enter remarks concerning the file.

When the File_Info window appears during the execution of the command "File_Save", then the corresponding entries can be made in the various fields (with the exception of "Date", "Time", "File name" and "Card type", which cannot be edited). When the File_Info window appears during the execution of the command "File_File-Info", then the various fields cannot be edited.

7.5.7 File_Activate Off Line / Activate On Line

Off Line

With this command, the connection with the SD6-Electronics is interrupted. All menu points, which call for a communication with the SD6-Electronics, are blocked. The PASO DSV/SD6 software now runs in the "Off Line mode". The loading, saving and the editing of parameter files is possible in this mode.

On Line

With this command, the connection with the SD6-Electronics is established. The communication with the SD6-Electronics is briefly tested. If the connection works, then the user has the option of taking over the parameters from the SD6-Electronics or of transferring the parameters to the SD6-Electronics. During the transfer of the parameters, the user has the possibility of aborting the operation.

Before parameters are transferred to the SD6-Electronics, a verification is carried out as to whether the configuration of the SD6-Electronics supports the parameter values. The configuration corresponds here to the number of the solenoids. If the configuration of the connected SD6-Electronics do not match with the current configuration of the PASO DSV/SD6, a message will be displayed and the current configuration from the PASO DSV/SD6 will change automatically over to the new configuration.

If the parameters have been taken over by the SD6-Electronics, then they will be checked in the case of a limiting value excess. If one or more parameter values are outside the tolerance, a message will be displayed and the parameter value will be set to the default value (refer to section "[Limiting value error](#)"^[87]). The PASO

DSV/SD6 will stay in the "Off Line"-mode. For going On Line in this case, the parameter must be transferred to the SD6-Electronics. If the transfer was successful and the limiting value check was also successful, then the software subsequently runs in the "On Line"-mode. The loading of parameter files is not possible in this mode.

The current mode will be displayed in the status line.

7.5.8 File_SD6 datarecord info

This menu point is only active in the "On Line"-mode.

Under this menu the current data set information of the connected SD6-Electronics appears. The data correspond to the last change to the SD6-Electronics data carried out.

7.5.9 File_Exit

With this command, the PASO DSV/SD6 is terminated. If parameter data have been changed and have not yet been saved, then the question appears, as to whether these data should be saved. This is referring only to the save in file. On the SD6-Electronics, the parameter will be saved automatically by clicking on the button "OK" in the corresponding windows (refer to section ["Store parameter"](#) ⁸⁷).

7.6 Profile-Menu

The SD6-Electronics is in a position to save - and to run through complete travel profiles, which have been predefined by the operator beforehand. A travel profile is a sequence of individual profiles (sequences), which define a course of movement.

7.6.1 Sequence

A sequence consists of the travel command data and the stop time (dwell time after reaching the target position)

A sequence is defined by the operator with the help of the travel command data entered through the keyboard.

The travel command data contain:

- Command position (target - or end position of the sequence) **xtarget**
- Command speed value (command travelling speed of the process) **vpreset**
- Acceleration (acceleration or deceleration necessary for reaching the travelling speed, starting out from a sequence start speed) **as**
- Deceleration (deceleration or acceleration necessary for reaching the sequence end speed) **ds**
- Stop time (possible dwell time after reaching the end position) **ts**

With the controller mode "Alternating control (2-sol)" it is possible to adjust for each sequence a command pressure. This command pressure is not part of the travel command data, but defines the maximum allowable pressure. If the actual pressure will exceed the adjusted command pressure during run the sequence, the pressure controller will be activated.

The travel command data of the sequences are saved in the EEPROM.

With the parameter "Sequence output" the selection can be made, if the state of the sequence should be displayed on the digital output 2 or not.

Which state is displayed can be selected with the parameter "Digital output 2" (refer to section "[Configuration Digital I/O](#)"⁶⁵⁻⁷¹)

- Selection "Inside target window / End of Seq": Digital output 2 is active, as soon as the sequence end is reached and the sequence stop time is running. After expiration of the the sequence stop, the output is inactive.
- Selection "Outside target window / Run of Seq": Digital output 2 ist active as long the sequence is running.

Mit dem Parameter "Sequenz Ende" kann die Sequenz- Ende Bedingung eingestellt werden:

- Selection "Command = Sequence end, if the command value has reached the command position Target":
- Selection "Feedback = Sequence end, if the feedback value has reached the command position. The profile generator waits to start a possible next to the sequence until the feedback valeu has reached the target window. The timing of the target profile is therefore delayed by the actual value. Target":

Example "Command = Target"

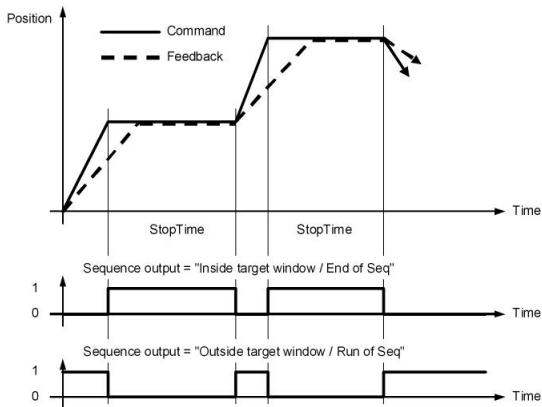

Example "Feedback = Target"

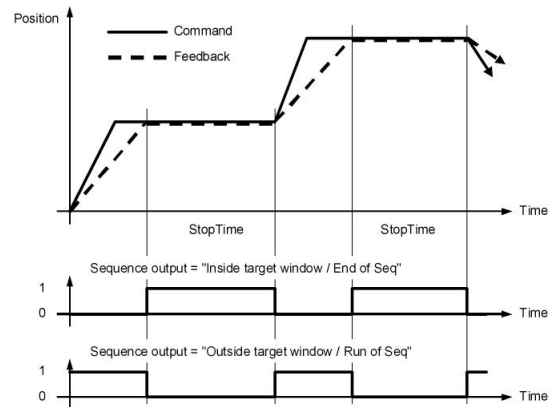

From the travel command data, the theoretical course of the sequence is calculated. The calculated course of the sequence is jointly determined by the limit parameters (position and speed at the beginning and end of the sequence) **and it can significantly differ from the travel command data entered. Command positions and possible stop times, however, are complied with in all cases.**

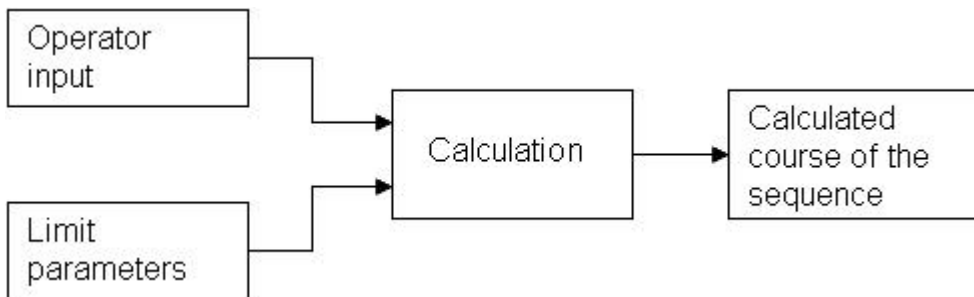

The limit parameters are:

- **xstart** (command position of the preceding sequence)
- **xtarget** (the command position entered)
- **vstart** (the starting speed of the sequence = target speed of the preceding sequence)
- **vtarget** (target speed when the command position is reached)

The target speed **vtarget** is determined by the operator input (travel command data) and the command speed **vpreset** of the next sequence.

vtarget is equal to zero when:

- The end of the profile has been reached
- **vpreset** of the next sequence is equal to zero (artificial profile end)
- A change of direction takes place at the end of the sequence
- A stop time **ts** greater than zero has been entered

In the other cases, **vtarget** is determined as follows from the operator input of acceleration **as**, deceleration **ds** and command speed **vpreset**:

Current sequence input value deceleration	Next sequence input value acceleration	vtarget , the target speed is equated to
ds not equal to zero	as not equal to zero	vpreset of the next sequence
ds equal to zero	as not equal to zero	vpreset of the current sequence
ds not equal to zero	as equal to zero	vpreset of the next sequence

ds equal to zero	as equal to zero	vpreset of the next sequence
-------------------------	-------------------------	-------------------------------------

Adaptation of the Acceleration or Deceleration to the Limit Parameters

In order for the target speed **vtarget** to be reached, the entered values for the acceleration **as** or deceleration **ds** are adapted if necessary (e.g. reverse digit sign, i.e. acceleration becomes deceleration or vice versa, or if so required change the value of the acceleration or deceleration). In conjunction with the other limit parameters, this results in the calculated course of the sequence. The adapted values in contrast to the entered ones are not saved in the EEPROM. They are only expressed in the graphic representation of the profile.

As a consequence of the physical limits of the axis control system, the calculated sequence course is possibly not implementable. **This is not verified by the Paso software.**

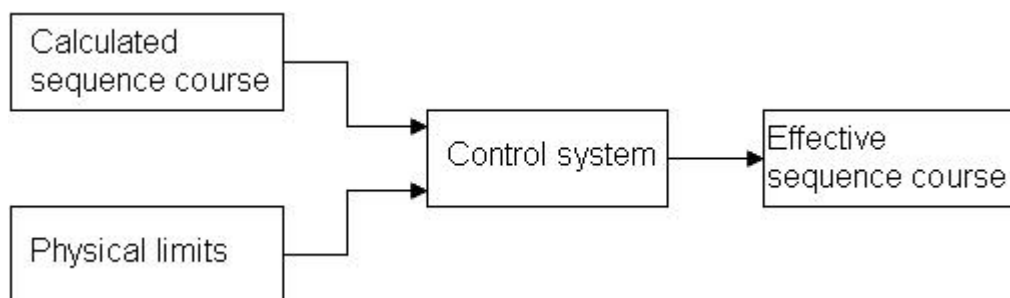

7.6.2 Travel Profile

A travel profile as a minimum consists of one sequence and, as a maximum, of the maximum programmable number of sequences. The sequences are consecutively numbered per travel profile (1..Maximum-Index). The sequence number 1 serves to run up to the profile starting position. Because the starting position of this sequence is not always known, this sequence is uniformly displayed in the graphic window with two blue arrows.

The travel profile ends either upon reaching the last sequence or else when reaching a sequence, which has been programmed with the speed 0 (artificial profile end). Thereafter the following sequences are not carried out. Per SD6-Electronics, a maximum of 50 sequences can be defined, which can be split-up in any manner required over the maximum 7 profiles.

A movement profile can either be run through completely or else step-by-step (sequence by sequence). The profile to be run through is selected through 3 digital inputs (= 7 profiles) (refer to section ["Digital inputs"](#)^[13^b]).

The selection of the profiles is done by driving the digital inputs 6 - 8. It applies the following relationship:

Digital input 6	Digital input 7	Digital input 8	Profile
0	0	0	0 (analogue command value)
1	0	0	1
0	1	0	2
1	1	0	3
0	0	1	4
1	0	1	5
0	1	1	6
1	1	1	7

With controller mode "Alternating control (2-soll)", note the following:

- in addition, the parameter "Command value position Signal type" must be set to "Profile" (refer to section ["Configuration Signal scaling"](#)^[53^b]).
- if also the adjusted command pressure should be used, the parameter "Command value pressure Signal type" must be set to "Profile" (refer to section ["Configuration Signal scaling"](#)^[53^b]).
- if the profile 0 is selected,
- wird das Fahrprofil 0 angewählt, no movement is performed (the external command value is not active)

With the help of the digital input digital input 4, the profile movement is started.
For every execution of a positioning, a start signal has to be applied. If the operating mode "Run through individual sequence" has been selected (digital input 3 on "Low"), each sequence has to be started individually. **If in doing so, a stop time = 0 has been programmed, the corresponding sequences are combined into one movement without any stopping time (sequence group).**

In the operating mode "Run through complete profile" (digital input 3 to "High"), after the start signal the complete profile is run through.

If a profile end is detected, then with the next start signal the processing starts again with the sequence 1. The completion announcement of every completed travel profile is effected with the setting of the output signal "Profile end". The state of each sequence is effected with the digital output 2 (depends on the parameter "Sequence output", refer to section "[Profile Generator-Window](#)");

Any and all positioning operations can be stopped, if the digital input 5 "Stop" is activated (low active).

7.6.3 Example

Speed - Stroke Diagram:

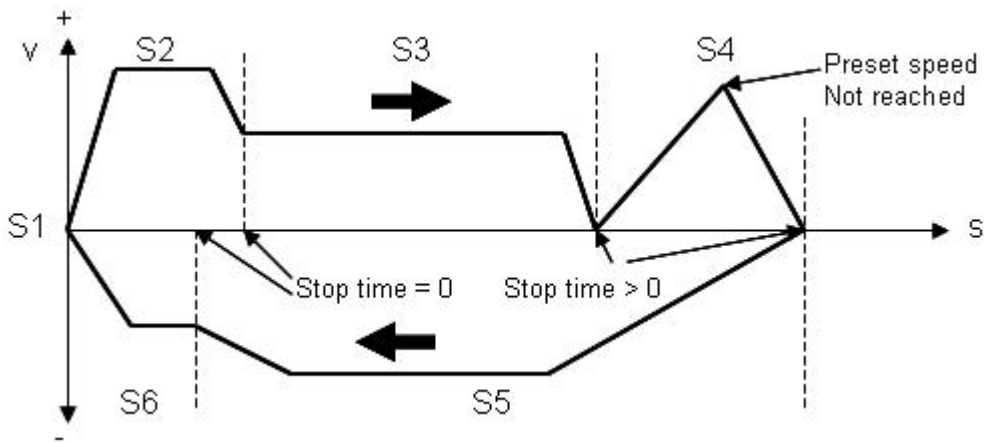

Stroke - Time Diagram:

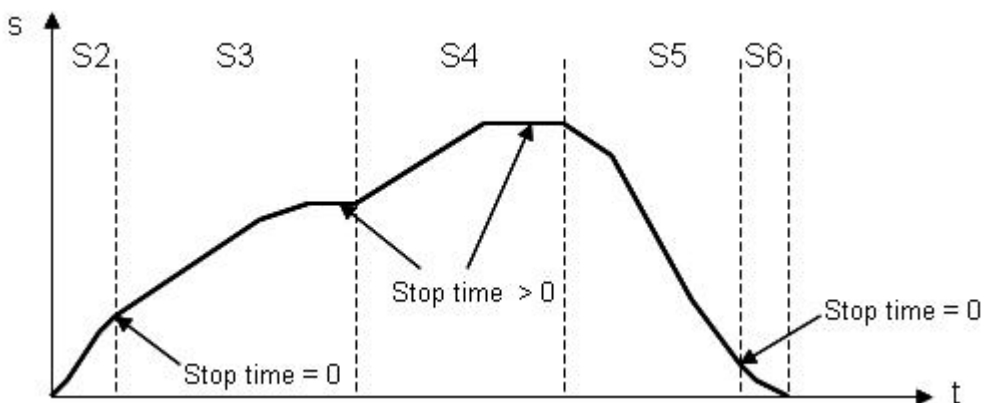

7.6.4 Profile Generator Window

In the profile generator window, the parameters described above can be predefined.

When running through the profiles, however, because of the predefined values (speed and position) of adjacent sequences it is possible, that the values entered into the fields acceleration and deceleration of the current sequence cannot be complied with. These values in this case are adapted during the calculation of the sequence.

In the display of the travel profiles, the following has to be noted:

- The complete travel profile is indicated in black.
- The current sequence is indicated in blue (violet in the time diagram) and in boldface.
- The current sequence group is indicated in blue (violet).
- If at the end of the sequence a stop time has been defined, then this is indicated with a red cross.
- The 1st sequence is not indicated. It solely serves to predefine a defined starting position.

By clicking on a sequence in the graphic window with the left-hand mouse button, it automatically becomes the current sequence. The field „Sequence No.” is adapted accordingly.

In the graphic window, the current travel profile is displayed as a speed - stroke - or stroke - time diagram. The changeover between the two types of diagram takes place by pushing the right-hand mouse button and selecting the required type of diagram, or else with the key combination CTRL+D.

Attention: When leaving the window with the key „Cancel”, all data, which have not previously been saved by means of the key „OK”, are lost!

Field	Parameter description	Range / Step size
Profile Number	Here the number of the required profile can be selected.	1 .. 7
Profile End	Here the condition for setting the digital output 4 "Profile End" can be selected: - Profile end, if the command value has reached the command position - Profile end, if the feedback value has reached the command position	Command = Target Feedback = Target
Sequence Number	Here the number of the required sequence can be selected. At the profile end (empty sequence), the delete-key is deactivated. Browsing through the sequences is also possible by means of the key combination CTRL + á or CTRL + â	1 .. 50
Insert / delete	With these two keys, a sequence can be inserted into the current profile or deleted from it.	
Take over	With this key, the current values are taken over into the current profile.	
Command position	Predefinition of the end position.	
Speed	Predefinition of the command speed.	0...max. speed
Travelling time	Travelling time of the current sequence excluding stop time, only display. (Only appears in the stroke - time diagram)	
Acceleration	Predefinition of the command acceleration.	0...max. acceleration
Deceleration	Predefinition of the command deceleration.	0...max. acceleration
Stop time	Predefinition of the stop time following a sequence end.	0...10sec
Sequence Output	Predefinition, whether the sequence output is to be activated or not when the sequence end has been reached.	on / off
Sequence End	Here the condition for the sequence end can be selected - Sequence end, if the command value has reached the command position - Sequence end, if the feedback value has reached the command position	Command = Target Feedback = Target
Sequence travelling		
Complete profile	If this input is activated, the commands „Home” and „Start”	

Field	Parameter description	Range / Step size
	refer to the current profile, if not, to the current sequence.	
Home	The axis will move to the starting position of the current sequence (or of the current profile, if the input „Complete profile“ is actuated).	
Start	The current sequence (or current profile, if the input „Complete profile“ is activated) is run through. The „Start“ key can only be activated, if the „Home“ key has been actuated beforehand.	
Direct operation		
Drive enable	If this key is pushed, the commands of „Sequence travelling“ and „Direct operation“ can be executed, otherwise they are disabled.	
Graphic window	<ul style="list-style-type: none"> • Changeover between the speed - stroke - and stroke - time diagram by pushing the right-hand mouse button and selection of the required type of diagram, or else with the key combination CTRL+D. • With the combination „CTRL+Left-hand mouse key“, the graphic display is zoomed in, with the combination „CTRL+Right-hand mouse key“, the graphic display is zoomed out. • With the combination „SHIFT+CTRL+Left-hand mouse key“, the graphic display can be moved. • By clicking on a sequence in the graphic window with the left-hand mouse key, this sequence automatically becomes the current sequence. The field „Sequence No.“ is accordingly adapted. 	

7.7 Parameters-Menu

In this window, all parameter values of the SD6-Electronics will be adjusted.

7.7.1 Parameters_Valves

In this window, all settings specific to the valves will be made. In the factory, the SD6-Electronics will be adjusted to the valve. **By changing the valves parameters, the valve characteristic is changed also. This has a influence on the system response.** With the menu item "Configuration_Default setting", the values set in the factory can be reloaded at any time.

Field	Parameter description	Range / Step
Direct solenoid operation	If this switch is selected, an internal command value from 0% resp. 100% will be active during the setting of the Imin resp. Imax. If this switch is not selected, the external command value will be active. This command is only active in the "On Line"-mode and if the operating mode is set to "Remote PASO".	
Solenoid current	The minimum and the maximum solenoid current can be set separately for each solenoid output, corresponding to 0% resp. 100% command value. In the "Off Line"-mode, the displayed current value is the theoretical command current. This makes it possible to set the Imin/Imax values without a solenoid or a valve, connected to the SD6-Electronics. In the "On Line"-mode, if the Imin setting is active, a command value of 0% resp. if the Imax setting is active, a command value of 100% is automatically applied internally (only if the switch "Direct solenoid operation" is selected). As a result of the digitalisation, the numbers entered max be modified to less "rounded-off" number.	
Imin A	Set minimum solenoid current A. (= solenoid current by 0% command value)	0 ... 950mA 1.8mA (24V-Version) 2.3mA (12V-Version)
Imax A	Set maximum solenoid current A. (= solenoid current by 100% command value) For the max. current refer to section " Electrical specifications " ⁵ .	Imin ... max. current 1.9mA (24V-Version) 2.3mA (12V-Version)
Imin B (only 2-solenoid version)	Set minimum solenoid current B. (= solenoid current by 0% command value)	0 ... 950mA 1.9mA (24V-Version) 2.3mA (12V-Version)
Imax B (only 2-solenoid version)	Set maximum solenoid current B. (= solenoid current by 100% command value) For the max. current refer to section " Electrical specifications " ⁵ .	Imin ... max. current 1.9mA (24V-Version) 2.3mA (12V-Version)
Frequency	The dither frequency can be set in steps.	2, 4, 6, 8, 10, 12, 14, 16, 18, 20, 25, 30, 35, 40, 45, 50, 55, 60, 70, 80, 100, 125, 165, 250, 500Hz
Level	Level of the superimposed dither signal	0 ... 399mA 3.8mA (24V-Version) 4.6mA (12V-Version)
Deadband	Command value < Deadband = 0 mA solenoid current A Command value >= Deadband = Imin .. Imax solenoid current A (Only Controller Mode 3 and 6)	0 ... 100% 0.1%

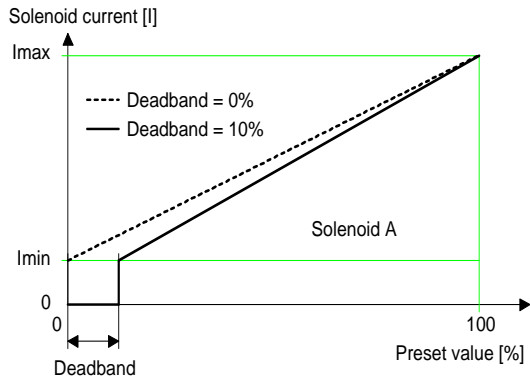

1-Solenoid version

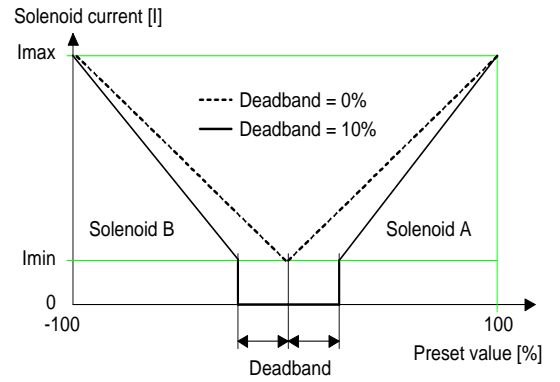

2-Solenoid version

Characteristic optimisation:

This setting is available only with a SD6-electronics with software version higher than 1.1.1.6 and PASO with software version higher than 1.5.0.9!

This menu enables the optimisation of the solenoid current adjustment of SD6-Electronics. A graphic is shown which represents the characteristic "Preset value (X-axis) – Solenoid current (Y-axis)". The graphic consists of 11 points, the first and the last point (100%) are preset.

Index	X-Axis value	Y-Axis value
0	0	0
10	100	100

The other graphic points can be adjusted either by tracking with the mouse or by entering the value at the numeric inputs. The resolution of the X-values is in %, those of the Y-values in 0.1 %. The X-values cannot be falling.

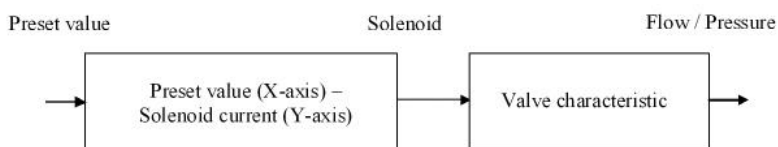

At shipping ex work (default settings) the preset value is transmitted proportionally to the solenoid current (default characteristic). In this case the characteristic "Preset value (X-axis – Solenoid current (Y-axis))" is linear. The same behaviour occurs at any time when the characteristic optimisation is turned off.

By modifying the default linear characteristic "Preset value (X-axis) – Solenoid current (Y-axis)" e.g. a progressive valve characteristic "Current - Flow/Pressure" can be compensated in such a way that a linear relation between preset value and Flow / Pressure is realised. The characteristic "Preset value (X-axis) – Solenoid current (Y-axis)" in this case should be adjusted in the "opposite progressive" direction (refer to the example characteristic below).

Additionally the characteristic optimisation must be turned on. This will be shown in the PASO-Status line (refer to section "[Starting of PASO DSV/SD6](#)"^[86]).

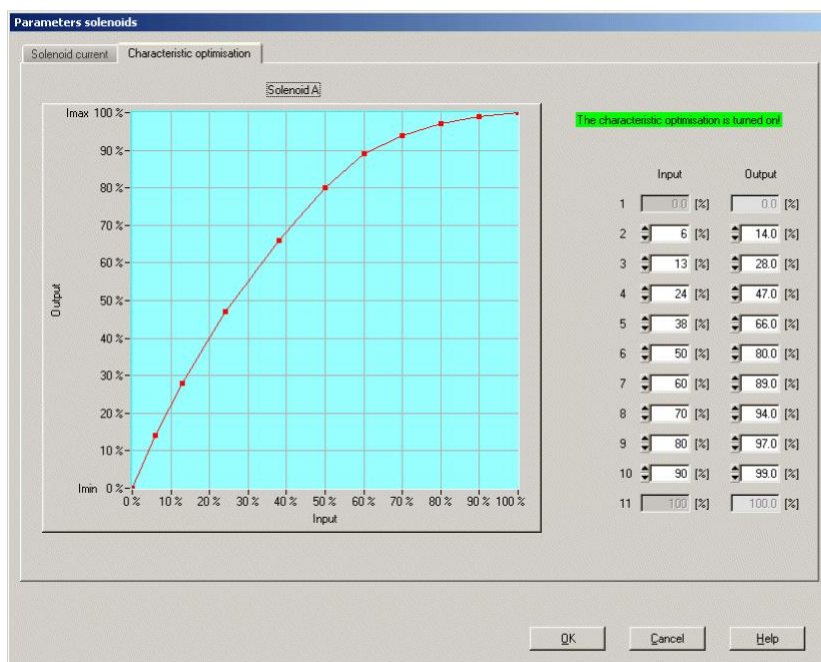

The solenoid current values are in the range Imin (0%) up to Imax (100%). Imin and Imax are adjusted in the

menu "Solenoid current". At an input value which is between two graphic points, the solenoid current is interpolated. If two or more preset values overlap, at the corresponding Preset value the highest current value is calculated.

In the case of an error in the characteristic values, the characteristic optimisation is automatically turned off.

7.7.2 Parameters_Ramps

In this window all settings of the ramp function are made. **The ramps can only be set in the controller mode "Pressure/flow valve open loop" and "Position open loop"**. In all other controller modes the ramp settings have no significance.

Field	Parameter description	Range / Step size
Ramps	After a command value jump the new command value is run-up to over a linear ramp (depending on the ramp time set). For both solenoids separately a ramp time Up and a ramp time Down can be set.	
Ramp A Up	The ramp time set refers to a command value jump from 0% to 100% for the solenoid A.	0 ... 51s 0.05s
Ramp A Down	The ramp time set refers to a command value jump from 100% to 0% for the solenoid A.	0 ... 51s 0.05s
Ramp B Up (only 2-solenoid version)	The ramp time set refers to a command value jump from 0% to 100% for the solenoid B.	0 ... 51s 0.05s
Ramp B Down (only 2-solenoid version)	The ramp time set refers to a command value jump from 100% to 0% for the solenoid B.	0 ... 51s 0.05s

7.7.3 Parameter_Command Value Generator

In this window all settings concerning the command value generator are made. **The command value generator can only be set in the controller modes "Pressure/flow valve closed loop (1-sol)", "Speed control closed loop (2-sol)", "Position closed loop (2-sol)", "Pressure control closed loop (2-sol)", "pQ control (2-sol)" and "Alternating control (2-sol)".** In all other controller modes, the command value generator settings have no significance.

Feld	Parameter description	Range / step size
Speed+	After a positive command value jump the new command value is run-up to over a linear ramp (depending on the speed+ set). On the actuator this corresponds to a certain travel speed.	0 ... 2000 Step size depends on the scaling
Speed-	After a negative command value jump the new command value is run-up to over a linear ramp (depending on the speed- set). On the actuator this corresponds to a certain travel speed.	0 ... 2000 Step size depends on the scaling
Slow Speed	„Normal“-speed in manual operation.	0 ... 2000 Step size depends on the scaling
Fast Speed	Rapid movement speed in manual operation.	0 ... 2000 Step size depends on the scaling

With the control mode "Alternating control (2-sol)", the parameters "Speed +" and "Speed -" can be set separately for the position and pressure controller.

With the control mode "pQ control (2-sol)", the parameters "Speed +" and "Speed -" can be set only for the pressure controller. For the open loop movement, the parameters "Ramp A up", "Ramp A down", "Ramp B up" and "Ramp B down" are available (refer to section "[Parameter_Ramps](#)"⁴⁶).

HINT: The limitation of speed can be disabled by entering the value 0. In this case, the command value acts **undelayed** onto the solenoid(s).

7.7.4 Parameter_Controller

In this window all settings concerning the controller are made. The controller is split-up into two independent blocks for positive and negative control difference. With this, asymmetrical characteristics of the hydraulic system can be compensated for.

Symmetrical setting	If this function is activated, the setting changes of a controller block are also transferred to the other controller block.	
Command feed forward	The command value is multiplied with this factor and added to the correcting variable of the controller. If this factor is 0, no command value proportion is added to the correcting variable.	0 ... 10 0.1
Velocity feed forward	The change of the command value (the increase speed of the command value) is multiplied with this factor and added to the correcting variable of the controller. If this factor is 0, no command value addition is added to the correcting variable.	0 ... 10 0.1
I-term, if control deviation > I-window outside	I-term is set to 0 if control deviation is outside the outside I-window. I-term is held if control deviation is outside the outside I-window.	set to 0 leave value
I-term, if controller is not active	I-term is set to 0 if the corresponding controller is not active I-term is held if the corresponding controller is not active This parameter is only available with controller mode "pQ control (2-sol)" and "Alternating control (2-sol)"	
P-amplification positive	P-amplification factor for positive control difference.	0 ... 25 0.1
I-window outside positive	Defines the outside I-window. If the control difference is within this window, the I-proportion is calculated with the set I-time positive.	Adapted to unit
I-window inside positive	Defines the inside I-window. If the control difference is within this window, the I-proportion is frozen.	Adapted to unit
D-amplification positive	D-amplification factor for positive control difference.	0 ... 10
I-time positive	Reaction time for the integrator. If the time is set to 0s, the integrator is switched off.	0 ... 10s 0.01s
D-time positive	Defines the time window, how long after a positive set-point value jump the D-controller is to be active.	0 ... 10s 0.1s
P-amplification negative	P-amplification factor for negative control difference.	0 ... 25 0.1
I-window outside negative	Defines the outside I-window. If the control difference is within this window, the I-proportion is calculated with the set I-time negative.	Adapted to unit
I-window inside negative	Defines the inside I-window. If the control difference is within this window, the I-proportion is frozen..	Adapted to unit
D-amplification negative	D-amplification factor for negative control difference.	0 ... 10
I-time negative	Reaction time for the integrator. If the time is set to 0s, then the integrator is switched off.	0 ... 10s 0.01s
D-time negative	Defines the time window, how long after a negative set-point value jump the D-controller is to be active.	0 ... 10s 0.1s

With the control mode "Alternating control (2-sol)", the parameters can be set separately for the position and pressure controller.

With the control mode "pQ control (2-sol)", the parameters are only valid for the pressure controller.

Example with outside and inside I-window:

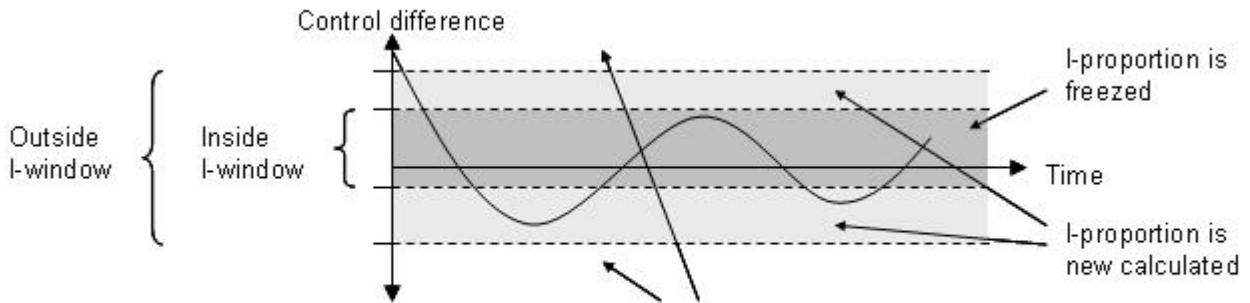

"I-proportion, if control deviation > I-window outside" = "set to 0": I-proportion is set to 0.
 "I-proportion, if control deviation > I-window outside" = "leave value": I-proportion is held.

Block diagram of the controller:

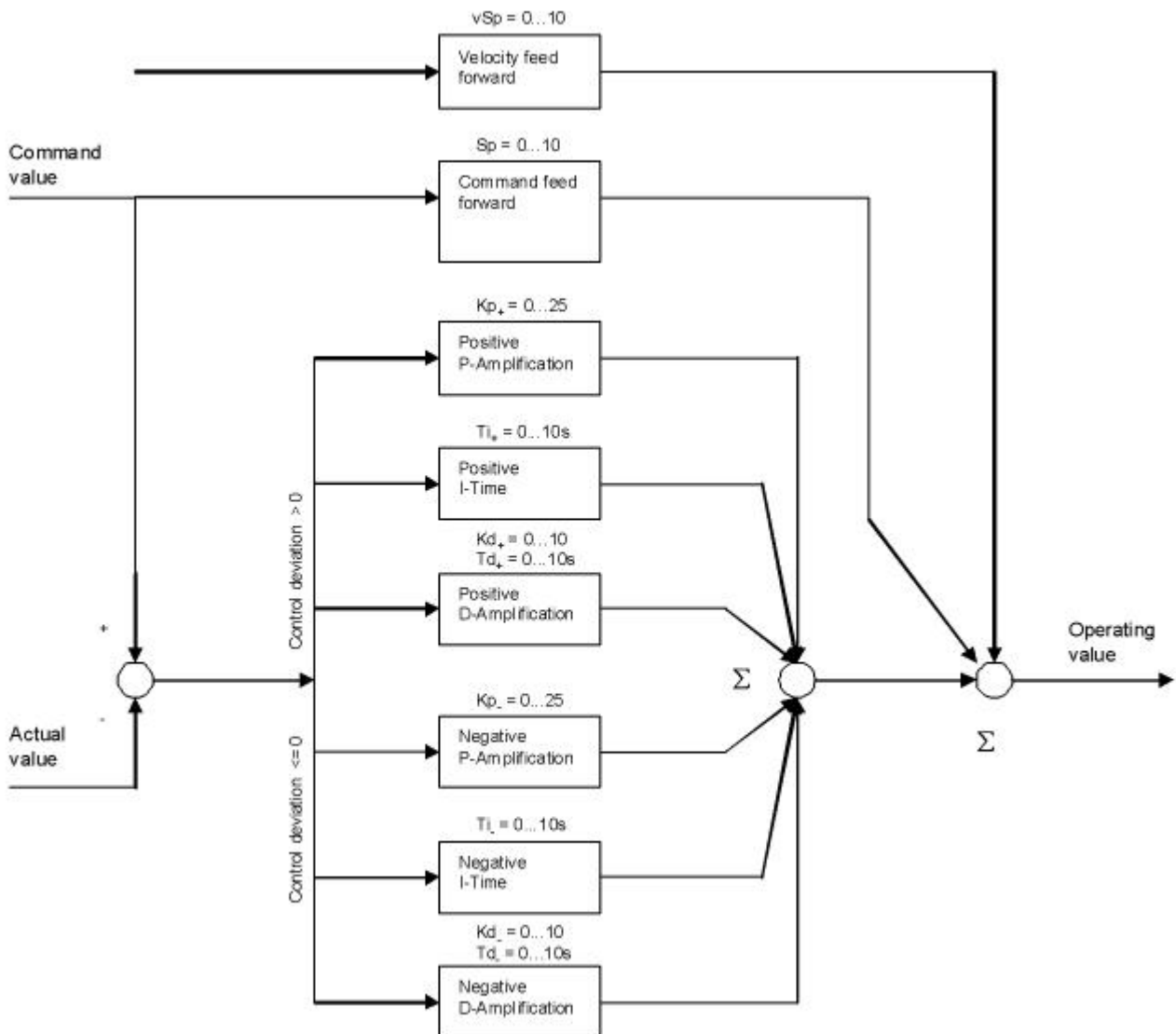

7.7.5 Parameter_Window

Field	Parameter description	Range / step size
Target window threshold	Defines the target window. HINT: This signal is routed normal or invers to digital output 2 and it's state is displayed in the Analysis-Window of PASO (refer to section " Analysis Values " 74).	Adapted to unit
Target window delay time	Delay time when falling below and exceeding the target window threshold.	0 ... 100ms 1ms
Trailing error window threshold	Defines the trailing window. HINT: This signal is routed normal or invers to digital output 3 and it's state is displayed in the Analysis-Window of PASO (refer to section " Analysis Values " 74).	Adapted to unit
Trailing error window delay time	Delay time when falling below and exceeding the target window threshold.	0 ... 100ms 1ms
Solenoid-off window threshold	Defines the solenoid-off window. If the control difference is within this window, the solenoid outputs are switched off.	Adapted to unit
Solenoid-off window delay time	Delay time when falling below and exceeding the solenoid-off window threshold.	0 ... 100ms 1ms

Target window::

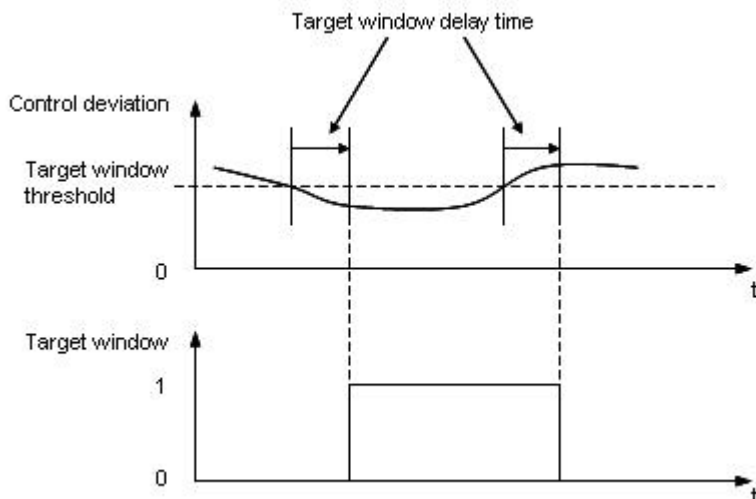

Trailing error window:

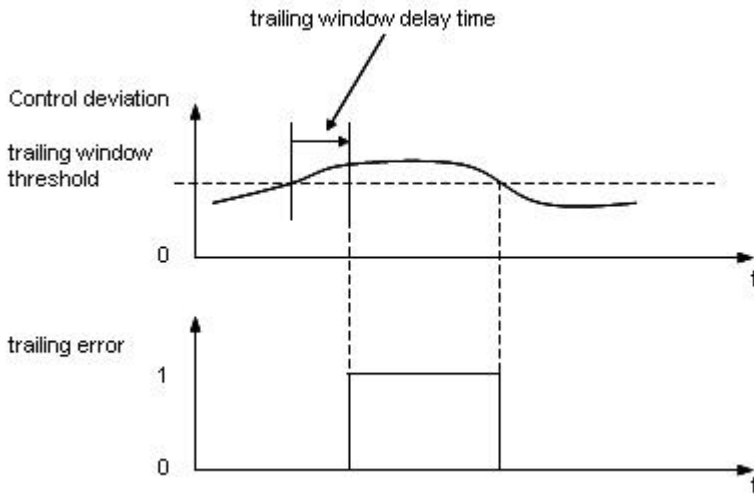

Solenoid-off window:

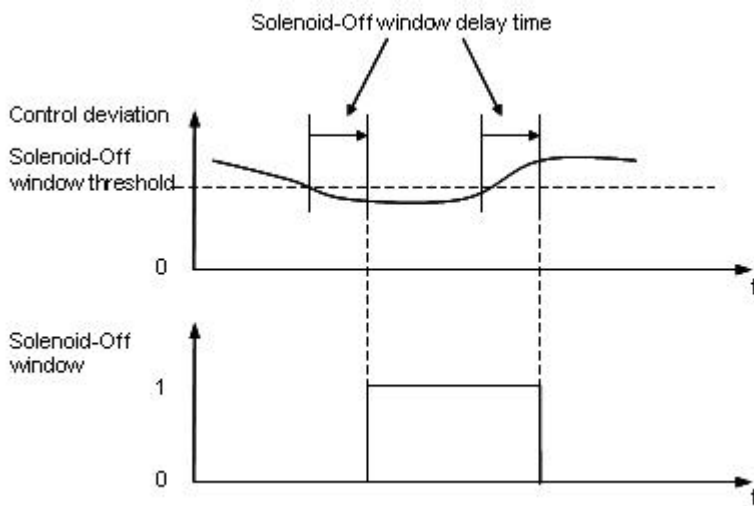

7.8 Configuration-Menu

In this window, the settings of the function of the SD6-Electronics will be made.

7.8.1 Configuration_Controller mode

In this window the configuration for the controller is made. Depending on the selected controller mode not all parameters can be adjusted.

Field	Parameter description	Range / step size
Controller mode	Select the desired controller mode (refer to section " Controller modes " ^[15]). Depending on the selected controller mode it is possible that other parameters are adjusted automatically.	Pressure/flow valve open loop = 3 Pressure/flow valve closed loop (1-sol) = 4 Position open loop = 6 Speed control closed loop (2-sol) = 7 Position control closed loop (2-sol) = 9 Pressure control closed loop (2-sol) = -5 pQ control (2-sol) = -9 Alternating control (2-sol) = -10
Output solenoid A	Solenoid output A can be inverted. Cannot be selected with the controller modes 6 and 9.	inverted not inverted
Output solenoid B	Solenoid output B can be inverted. Cannot be selected with the controller modes 6 and 9.	inverted not inverted
System control sense	With this function the solenoid outputs can be interchanged. With solenoid current A the solenoid output B is driven and with solenoid current B the solenoid output A is driven	inverted not inverted
Solenoid 'In Position'	off: Solenoids are switched off, when the solenoid-off window is reached. on: Solenoids are not switched off, even when the solenoid-off window is reached (refer to section " Parameter Window " ^[50])	off on
Imin always active (Position)	If this function is activated, then the solenoid current is never less than Imin. With the control mode "Alternating control (2-sol)", this parameter effects to the position controller	no yes
Imin always active (Pressure)	If this function is activated, then the solenoid current is never less than Imin. With the control mode "Alternating control (2-sol)", this parameter effects to the pressure controller	no yes

7.8.2 Configuration_Mode of operation

This menu point is only active in the SD6-state "Disabled" (refer to section "[SD6 State Machine](#)"^[11]).

In this window the operating mode of the SD6-Electronics is set. The operating mode can only be selected in case of controller mode "Pressure/flow valve open loop", "Position open loop", "Speed control closed loop (2-sol)" and "pQ control (2-sol)", in case of all other controller modes the operating mode has no significance.

Field	Parameter description	Range / step size
Operating mode	Select the required operating mode (refer to section " Mode of Operation " ^[52]). Depending on the selected operating mode it may be, that the signal type is automatically adapted.	Command value unipolar (1-sol) Command value unipolar (2-sol) Command value bipolar (2-sol) Command value unipolar (2-sol, selectable by digital input)

7.8.3 Configuration_Signal scaling

This menu point is only active in the SD6-state "Disabled" (refer to section "[SD6 State Machine](#)"^[11]).

In this window the settings and the scaling of the command value - and feedback value signal is made.

ATTENTION:

With controller mode "pQ control" and "Alternating control" the [dependencies of the inputs](#)^[53] must be respected!

Command value resp. Command value position (with controller mode "pQ control" and "Alternating control"):

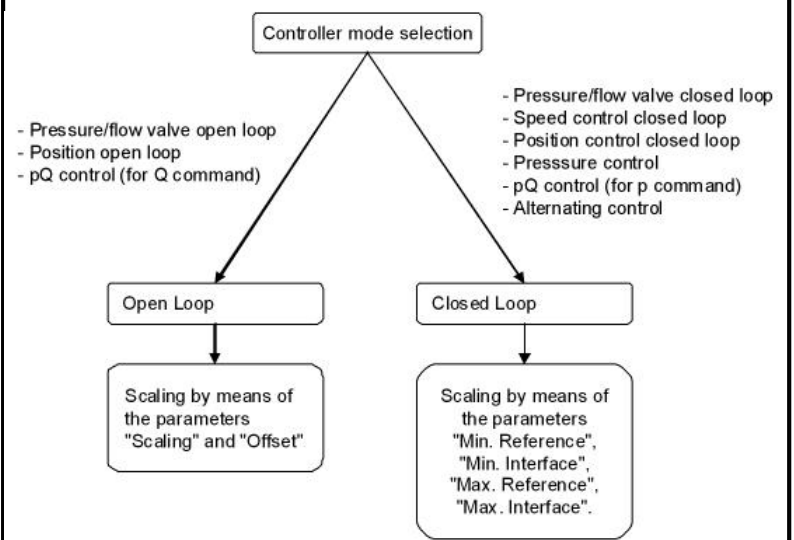
Field	Parameter description	Range / step size
Configuration	In this range the configuration of the command signal is done	
Signal type	In this field the required signal type can be selected. The signal type "+/-10 VDC" can only be selected in the controller mode "Pressure/flow valve open loop", "Position open loop", and "pQ control (2-sol)" and operating mode "Command value bipolar (2-sol)" (refer to section " Configuration Mode of operation " ^[52]). The signal type "Profile" can only be selected in the controller mode "Alternating control (2-sol)".	0...10 VDC +/-10 VDC 0...20 mA 4...20 mA Profile
Input used	Depending on the SD6 type different voltage resp.current inputs are available (refer to chapter " Technical specifications " ^[5]). The appropriate input for the selected signal type is automatically set. Different input for command and feedback signal should be used.	Analnp1 [V] Analnp2 [mA] Analnp3 [V] Analnp4 [mA]
Inversion	The analogue value read-in can be inverted (refer to the figure below). The command value input can only be inverted in the controller mode "Pressure/flow valve open loop" and "Position open loop".	no yes
Cable break	Switching-on/-off of the cable break detection of the analogue input signals (refer to section " Cable-break detection " ^[13]).	no yes
Scaling	In this range the scaling of the command signal is done. The scaling depends on the selected controller mode: <div style="text-align: center;">  <pre> graph TD A[Controller mode selection] --> B[Open Loop] A --> C[Closed Loop] B --> D["Scaling by means of the parameters 'Scaling' and 'Offset'"] C --> E["Scaling by means of the parameters 'Min. Reference', 'Min. Interface', 'Max. Reference', 'Max. Interface'."] </pre> </div> <ul style="list-style-type: none"> - Pressure/flow valve open loop - Position open loop - pQ control (for Q command) - Pressure/flow valve closed loop - Speed control closed loop - Position control closed loop - Pressure control - pQ control (for p command) - Alternating control 	

Field	Parameter description	Range / step size
Scaling	<p>With this parameter it is defined, by how many percent the command value is to change in case of a change of 1V, resp. 1mA at the analogue input (= gradient). If the signal type is changed, then the parameter scaling is automatically set to the corresponding default value (refer to table below).</p> <p>Attention: If the scaling does not correspond to the default value, the resolution is < 10-bit resp. < 16-bit!</p> <p>This parameter can only be set in case of an open loop controller modes</p>	0.001 ... 100.000% 0.001%
Offset	<p>With this parameter the zero point of the analogue signal is set (refer to the figure below).</p> <p>Depending on the signal type, the setting is in V or mA. Voltage: Current:</p> <p>This parameter can only be set in case of an open loop controller modes</p>	0 ... ±10.00V 0.01V 0 ... ±20.00mA 0.02mA
min interface	<p>Indicates the command A/D value in case of "min Reference commandvalue" (refer to the figure below).</p> <p>Voltage: Current:</p> <p>This parameter can only be set in case of an closed loop controller modes.</p>	0 ... 10.00V 0.01V 0 ... 20.00mA 0.02mA
max interface	<p>Indicates the command A/D value in case of "max Reference command value" (refer to the figure below).</p> <p>Voltage: Current:</p> <p>This parameter can only be set in case of an closed loop controller modes.</p>	0 ... 10.00V 0.01V 0 ... 20.00mA 0.02mA
min reference	<p>Indicates the absolute command value measured value in a freely selected measuring point (refer to the figure below).</p> <p>The min reference command value has to be smaller than the max reference command value.</p> <p>This parameter can only be set in case of an closed loop controller modes..</p>	Dependent on unit
max reference	<p>Indicates the absolute command value measured value in a freely selected measuring point (refer to the figure below)..</p> <p>The max reference command value has to be higher than the min reference command value.</p> <p>This parameter can only be set in case of an closed loop controller modes..</p>	Dependent on unit

Feedback value resp. Feedback value position (with controller mode "pQ control" and "Alternating control"):

These parameters are only adjustable with controller modes "Pressure/flow valve closed loop (1-sol)", "Speed control closed loop (2-sol)", "Position control closed loop (2-sol)", "Pressure control closed loop (2-sol)" and "Alternating control (2-sol)"

Field	Parameter description	Range / step size
Configuration	In this range the configuration of the feedback signal is done	
Signal type	In this field the required signal type can be selected.	0...10 VDC +/-10VDC 0...20 mA 4...20 mA SSI-Gray SSI-Binary Start/Stop
Input used	Depending on the SD6 type different voltage resp.current inputs are available (refer to chapter " Technical specifications " ⁵⁻¹¹). The appropriate input for the selected signal type is automatically set. Different input for command and feedback signal should be used	Analnp1 [V] Analnp2 [mA] Analnp3 [V] Analnp4 [mA] DigSens [X3]
Cablebreak detection	Switching-on/-off the cable break detection of the analogue input signals (refer to section " Cablebreak detection " ¹³⁻¹¹).	no yes
Scaling	In this range the scaling of the feedback signal is done.	
min interface	Indicates the command A/D value in case of "min Reference commandvalue" (refer to the figure below). This parameter is only relevant if the used input is set to Analnp1, Analnp2, Analnp3 or Analnp4. Voltage: Current:	0 ... 10.00V 0.01V 0 ... 20.00mA 0.02mA
max interface	Indicates the command A/D value in case of "max Reference commandvalue" (refer to the figure below). This parameter is only relevant if the used input is set to Analnp1, Analnp2, Analnp3 or Analnp4. Voltage: Current:	0 ... 10.00V 0.01V 0 ... 20.00mA 0.02mA
min reference	Indicates the absolute feedback value measured in a freely selectable measuring point (refer to figure below). The min reference feedback value has to be smaller than the max reference feedback value. This parameter is only relevant if the used input is set to Analnp1, Analnp2, Analnp3 or Analnp4.	Dependent on unit

Field	Parameter description	Range / step size
max reference	<p>Indicates the absolute feedback value measured in a freely selectable measuring point (refer to figure below).</p> <p>The max reference feedback value has to be higher than the min reference feedback value.</p> <p>If the used input is to DigSens [X3], this value should correspond to the maximum possible stroke of the cylinder.</p>	Dependent on unit
Offset	Indicates the offset of the digital measuring system. This parameter is only relevant if the used input is set to DigSens [X3].	Dependent on unit
Resolution	Indicated the resolution of the digital measuring system. This parameter is only relevant if the signal type is set to SSI-Gray or SSI-Binary.	unit / inc
Bit number	Indicates the number of bits of the digital measuring system. This parameter is only relevant if the signal type is set to SSI-Gray or SSI-Binary.	
v-propagation	Indicates the propagation speed of the digital measuring system. This parameter is only relevant if the signal type is set to Start/Stop.	unit / s

Command value pressure (only with controller mode "pQ control" and "Alternating control"):

Field	Parameter description	Range / step size
Configuration	In this range the configuration of the command signal is done	
Signal type	<p>In this field the required signal type can be selected.</p> <p>The signal type "+/-10 VDC" can only be selected in the controller mode "Pressure/flow valve open loop", "Position open loop", and "pQ control (2-sol)" and operating mode "Command value bipolar (2-sol)" (refer to section "Configuration_Mode of operation"^[52]).</p> <p>The signal type "Profile" can only be selected in the parameter "Signal type position" is set also to "Profile"</p>	0...10 VDC +/-10 VDC 0...20 mA 4...20 mA Profile
Input used	<p>Depending on the SD6 type different voltage resp.current inputs are available (refer to chapter "Technical specifications"^[54]).</p> <p>The appropriate input for the selected signal type is automatically set.</p> <p>Different input for command and feedback signal should be used.</p>	Analnp1 [V] Analnp2 [mA] Analnp3 [V] Analnp4 [mA]
Cable break	Switching-on/-off of the cable break detection of the analogue input signals (refer to section " Cable-break detection " ^[13]).	no yes
Scaling	In this range the scaling of the command signal is done.	
min interface	<p>Indicates the command A/D value in case of "min Reference commandvalue".</p> <p>Voltage:</p> <p>Current:</p>	0 ... 10.00V 0.01V 0 ... 20.00mA 0.02mA
max interface	<p>Indicates the command A/D value in case of "max Reference command value".</p> <p>Voltage:</p>	0 ... 10.00V

Field	Parameter description	Range / step size
	Current:	0.01V 0 ... 20.00mA 0.02mA
min reference	Indicates the absolute command value measured value in a freely selected measuring point (refer to the figure below). The min reference command value has to be smaller than the max reference command value.	Dependent on unit
max reference	Indicates the absolute command value measured value in a freely selected measuring point (refer to the figure below).. The max reference command value has to be higher than the min reference command value.	Dependent on unit

Feedback value pressure (only with controller mode "pQ control" and "Alternating control"):

Field	Parameter description	Range / step size
Option	In this range the type of the connected pressure sensor is selected	
Sensor type	The pressure feedback signal is coming from a pressure or force sensor with an absolute signal (V or mA) The pressure feedback signal is built as a differential signal from two pressure or force sensors (V or mA)	Absolute signal (1 sensor) Differential pressure (2 sensors)
Configuration sensor 1	In this range the configuration of the feedback signal from sensor 1 is done	
Signal type	In this field the required signal type can be selected.	0...10 VDC +/-10VDC 0...20 mA 4...20 mA
Input used	Depending on the SD6 type different voltage resp.current inputs are available (refer to chapter " Technical specifications " ^[54]). The appropriate input for the selected signal type is automatically set. Different input for command and feedback signal should be used	Analnp1 [V] Analnp2 [mA] Analnp3 [V] Analnp4 [mA]
Cablebreak detection	Switching-on/-off the cable break detection of the analogue input signals (refer to section " Cablebreak detection " ^[13]).	no yes
Scaling sensor 1	In this range the scaling of the feedback signal from sensor 1 is done.	
min interface	Indicates the command A/D value in case of "min Reference commandvalue" (refer to the figure below). Voltage: Current:	0 ... 10.00V 0.01V 0 ... 20.00mA 0.02mA
max interface	Indicates the command A/D value in case of "max Reference commandvalue" (refer to the figure below). Voltage: Current:	0 ... 10.00V 0.01V 0 ... 20.00mA 0.02mA

Field	Parameter description	Range / step size
min reference	Indicates the absolute feedback value measured in a freely selectable measuring point (refer to figure below). The min reference feedback value has to be smaller than the max reference feedback value.	Dependent on unit
max reference	Indicates the absolute feedback value measured in a freely selectable measuring point (refer to figure below). The max reference feedback value has to be higher than the min reference feedback value.	Dependent on unit
Scaling sensor 2	In this range the scaling of the feedback signal from sensor 1 is done. This range is only active, if the parameter "Sensor type" is set to "Differential pressure (2 sensors)".	
min interface	Indicates the command A/D value in case of "min Reference commandvalue" (refer to the figure below). Voltage: Current:	0 ... 10.00V 0.01V 0 ... 20.00mA 0.02mA
max interface	Indicates the command A/D value in case of "max Reference commandvalue" (refer to the figure below). Voltage: Current:	0 ... 10.00V 0.01V 0 ... 20.00mA 0.02mA
min reference	Indicates the absolute feedback value measured in a freely selectable measuring point (refer to figure below). The min reference feedback value has to be smaller than the max reference feedback value.	Dependent on unit
max reference	Indicates the absolute feedback value measured in a freely selectable measuring point (refer to figure below). The max reference feedback value has to be higher than the min reference feedback value.	Dependent on unit

General:

Field	Parameter description	Range / step size
Display unit	In this field the required unit can be selected. Controller mode pressure/flow control: Controller mode speed control: Controller mode position control: All controller modes: With controller modes "Alternating control", the displayed unit can be set separately for the position and pressure controller.	bar, psi, kN, MPa l/min, mm/s, 1/Min, inch/s, deg/s mm, deg, inch Own unit
Own unit	If with "Display unit" the type "Own unit" was selected, then an own unit can be entered in this field.	Min. number of characters: 1 Max. number of characters: 5

Dependencies of the inputs

With controller mode "pQ-control" and "Alternating control", the following dependencies of the inputs have to be considered:

- Because the SD6 card has only 4 analogue inputs, the parameter "Sensor type" can only be set to "Differential pressure (2 sensors)" if either
 - the parameter "Command value position - Signal type" = "Profile" or
 - the parameter "Feedback value position - Signal type" = "SSI-Gray", "SSI-Binary" or "Start/Stop" or
 - the position command value is specified via fieldbus (object "Device Mode" = "1") or
 - the pressure command value is specified via fieldbus (object "Device Mode Pressure" = "1") or
- The parameter "Command value pressure - Signal type" can only be set to "Profile" if
 - the parameter "Command value position - Signal type" is also set to "Profile"
- The parameter "Command value position - Signaltyp" can only be set to "0...10 VDC", "+/-10VDC", "0...20 mA" or "4...20 mA" if
 - the parameter "Command value pressure - Signal type" is not set to "Profile"

Controller mode "Pressure/flow valve open loop", "Position open loop", and "pQ control (2-sol)" (for the Q command):

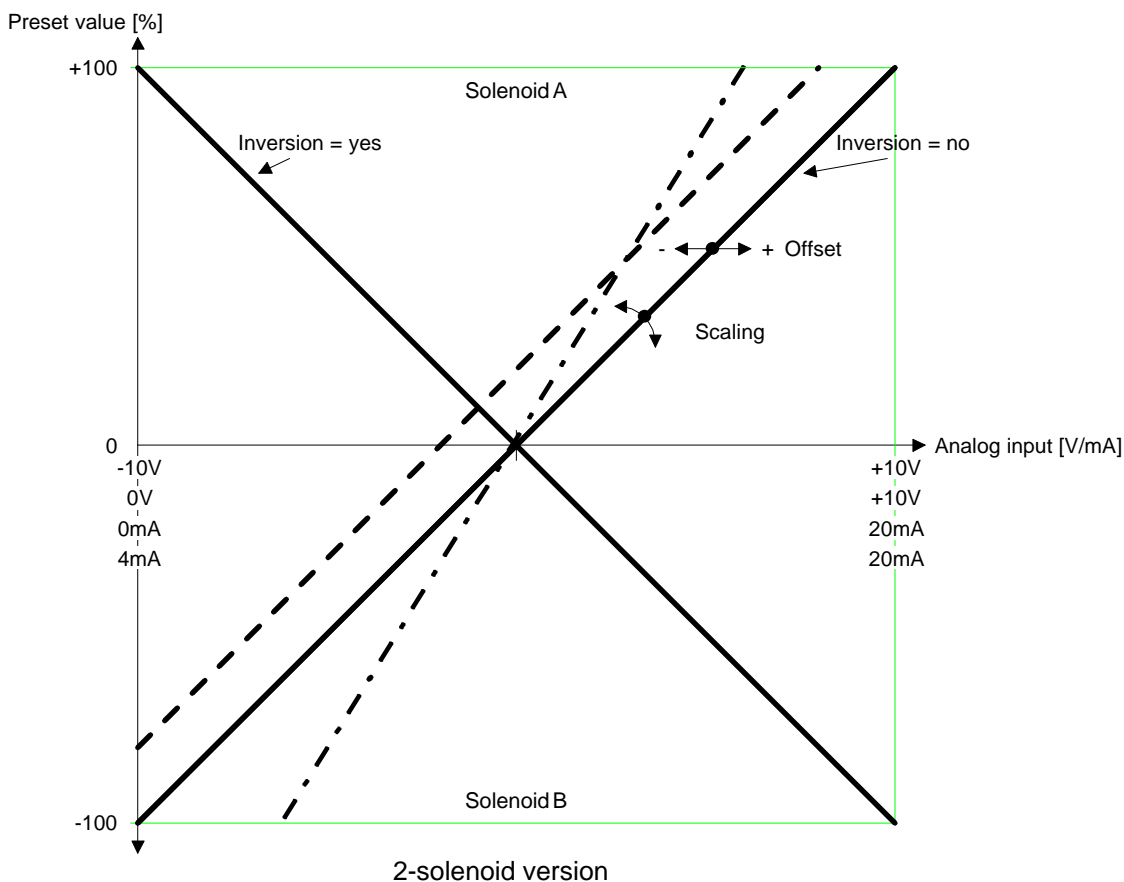

Examples:

Used analogue signal: 4 ... 20 mA
 Command-Zero: $(4 \text{ mA} + 20 \text{ mA}) / 2 = 12 \text{ mA}$ (middle of signal)
 Selected signal type: 4 ... 20 mA
 Standard Command-Zero: 12 mA (middle of signal)
 Adjustment offset: $12 \text{ mA} - 12 \text{ mA} = \mathbf{0 \text{ mA}}$
 Signal working range: $20 \text{ mA} - 4 \text{ mA} = 16 \text{ mA}$
 Signal range per solenoid: 8 mA (= Signal working range / 2)
 Adjustment Scaling: $100 \% / 8 \text{ mA} = \mathbf{12.5 \% / mA}$

Used analogue signal: 1.0 ... 8.0 V
 Command-Zero: $(1.0 \text{ V} + 8.0 \text{ V}) / 2 = 4.5 \text{ V}$ (middle of signal)
 Selected signal type: 0 ... 10 V
 Standard Command-Zero: 5 V (middle of signal)
 Adjustment offset: $4.5 \text{ V} - 5 \text{ V} = \mathbf{-0.5 \text{ V}}$
 Signal working range: $8.0 \text{ V} - 1.0 \text{ V} = 7.0 \text{ V}$
 Signal range per solenoid: 3.5 V (= Signal working range / 2)
 Adjustment scaling: $100 \% / 3.5 \text{ V} = \mathbf{28.57 \% / V}$

Used analogue signal: -9.0 ... +9.0 V
 Command-Zero: $(-9.0 \text{ V} + 9.0 \text{ V}) / 2 = 0.0 \text{ V}$ (middle of signal)
 Selected signal type: +/- 10 V
 Standard Command-Zero: 0.0 V (middle of signal)
 Adjustment offset: $0.0 \text{ V} - 0.0 \text{ V} = \mathbf{0.0 \text{ V}}$
 Signal working range: $9.0 \text{ V} - (-9.0 \text{ V}) = 18.0 \text{ V}$
 Signal range per solenoid: 9.0 V (= Signal working range / 2)
 Adjustment scaling: $100 \% / 9.0 \text{ V} = \mathbf{11.11 \% / V}$

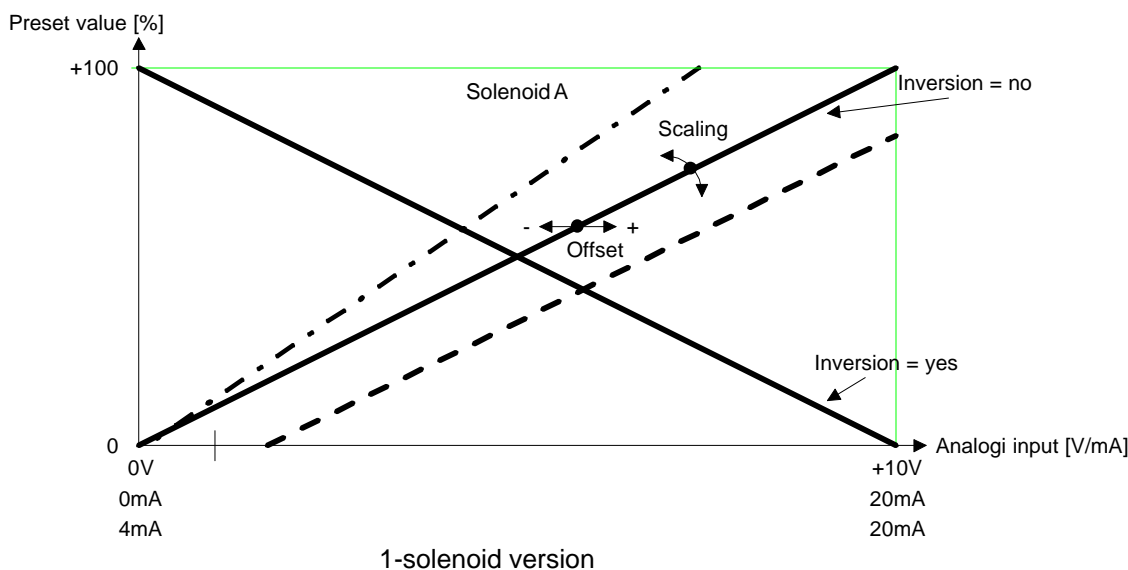

Examples:

Used analogue signal: 4 ... 20 mA
 Command-Zero at: 4 mA
 Selected signal type: 4 ... 20 mA
 Standard Command-Zero at: 4 mA
 Adjustment offset: $4 \text{ mA} - 4 \text{ mA} = \mathbf{0 \text{ mA}}$
 Signal working range: $20 \text{ mA} - 4 \text{ mA} = 16 \text{ mA}$
 Signal range per solenoid: 16 mA (= Signal working range)
 Setting scaling: $100 \% / 16 \text{ mA} = \mathbf{6.25 \% / mA}$

Used analogue signal: 2.0 ... 9.0 V
 Command-Zero at: 2.0 V
 Selected signal type: 0 ... 10 V
 Standard Command-Zero at: 0.0 V
 Adjustment offset: 2.0 V - 0.0 V = **2.0 V**
 Signal working range: 9.0 V - 2.0 V = 7 V
 Signal range per solenoid: 7.0 V (= Signal working range)
 Setting scaling: 100 % / 7.0 V = **14.29 %/V**

Default - values of the parameter "Scaling"

Operating mode	Signal type			
	0 ... 10 VDC	+/-10 VDC	0 ... 20 mA	4 ... 20 mA
Command value unipolar (1-sol)	10 %/V	--	5 %/mA	6.25 %/mA
Command value unipolar (2-sol)	20 %/V	--	10 %/mA	12.5 %/mA
Command value bipolar (2-sol)	--	10 %/V	--	--
Command value unipolar (2-sol single)	10 %/V	--	5%/mA	6.25%/mA

Controller mode "Pressure/flow valve closed loop (1-sol)", "Speed control closed loop (2-sol)", "Position control closed loop (2-sol)", "Pressure control closed loop (2-sol)", "pQ control" (for p command) and "Alternating control (2-sol)":

In controller mode 4, 7 and 9 the scaling is not set by means of gain and offset, but defined with two points. These points in the following are called scaling points. A scaling point consists of a reference value and an interface value.

Reference corresponds to the measuring value. In the following examples, the measuring value is a length. Interface corresponds to the analogue signal.

It is advisable to select the two scaling points as far apart from one another as possible. Attention has to be paid, that Min. Reference always has to be smaller than Max. Reference

Command value scaling:

In case of the command value normally the interface range and the reference range are known. From this two scaling points can be decided on without any measuring.

1st Example:

An external control system presets the command value in the form of a voltage signal (0 ... 10V). At 0V the position 0mm, and at 10V the position 100mm shall be run-up to.

Scaling point 1:	Min. Reference	=	0mm
	Min. Interface	=	0V

Scaling point 2:	Max. Reference	=	100mm
	Max. Interface	=	10V

2nd Example:

An external control system presets the command value in the form of a current signal (4 ... 20mA). At 4mA the position 0mm, and at 20mA the position 100mm shall be run-up to.

Scaling point 1:	Min. Reference	=	0mm
	Min. Interface	=	4mA

Scaling point 2:	Max. Reference	=	100mm
	Max. Interface	=	20mA

Feedback value scaling:

1. By means of direct solenoid actuation (chapter "Commands_Valve actuation" page 41) run-up to a position.
2. Measure the position (→ Reference value).
3. Measure the signal value of the feedback value sensor or select it by means of PASO (→ Interface value).
4. In this manner define two differing scaling points.

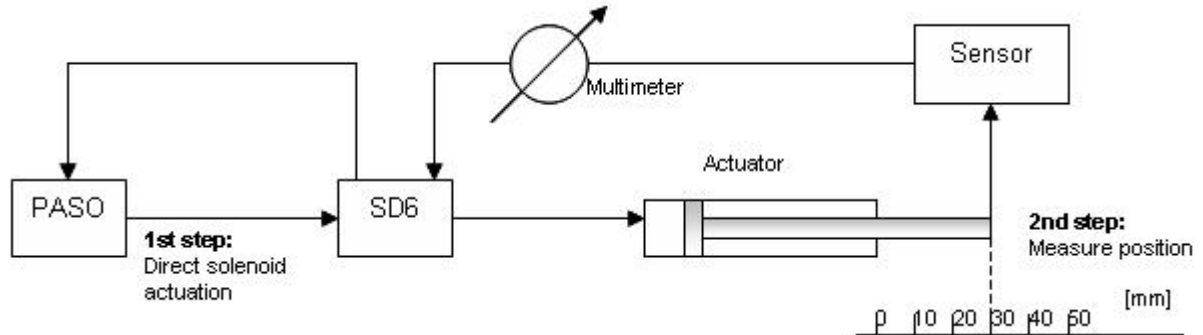

The following illustration shows various examples for the scaling. In feedback practice, the command value and the feedback value can be scaled differently.

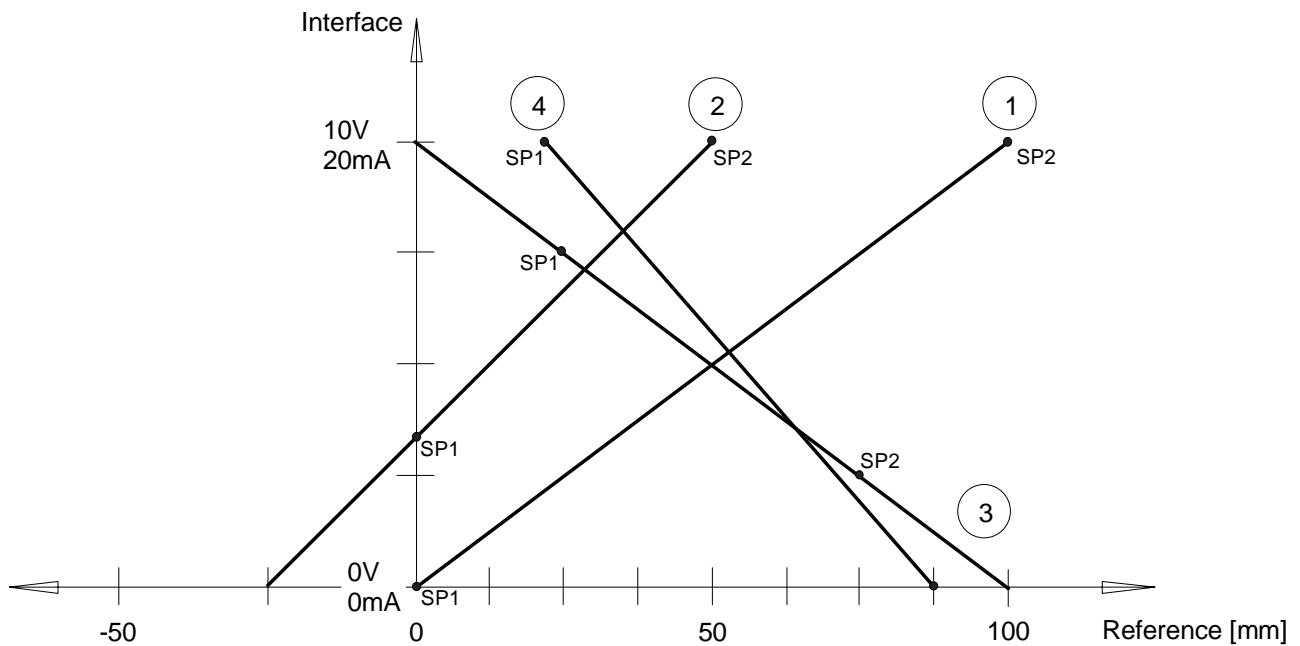

①

Scaling point 1:	Min. Reference	=	0mm
	Min. Interface	=	0V or 0mA
Scaling point 2:	Max. Reference	=	100mm
	Max. Interface	=	10V or 20mA

②

This example shows, that with positive interface values also negative reference values can be achieved.

Scaling point 1:	Min. Reference	=	0mm
	Min. Interface	=	03.33V or 6.67mA
Scaling point 2:	Max. Reference	=	50mm
	Max. Interface	=	10V or 20mA

③

This example shows, that the scaling points do not necessarily have to be the end points.

Scaling point 1:	Min. Reference	=	25mm
	Min. Interface	=	7.5V or 15mA
Scaling point 2:	Max. Reference	=	75mm
	Max. Interface	=	2.5V or 5mA

④

This example shows, that depending on the scaling 0mm are never reached.

Scaling point 1:	Min. Reference	=	25mm
	Min. Interface	=	10V or 20mA
Scaling point 2:	Max. Reference	=	87.5mm
	Max. Interface	=	0V or 0mA

7.8.4 Configuration_Analog Output

In this window the scaling of the analog output can be set.

The signal at the analog output corresponds to the controller output (controller variable), and can be used for driving a valve with integrated electronics which has a +/-10V interface.

Field	Parameter description	Range / Step
* Signal	This determines which signal is to be performed on the output (depending on the selected controller mode, different signals are available) - command value for the solenoid driver - scaled command value - scaled feedback value (only in closed loop modes 4, 7, 9) - scaled control deviation (only in closed loop modes 4, 7, 9)	Control value Command value Feedback value Control deviation
Min.interface	This parameter sets the minimal output voltage.	-10...+10V 0.01V
Max.interface	This parameter sets the maximal output voltage.	-10...+10V 0.01V
* Min. reference	With this signal, the value from Min. interface is issued	depending on the parameter "Signal"
* Max. reference	With this signal, the value from Max. interface is issued	depending on the parameter "Signal"

* This setting is available only with a SD6-electronics with software version > 1.1.1.6 and PASO with software version > 1.5.0.9!

7.8.5 Configuration_Digital IO

With this command, the digital inputs and outputs (refer to section "[Digital inputs](#)"^[13]) and "[Outputs](#)"^[15]) of the connected SD6-Electronics can be set to active, not active or released.

Field	Parameter description	Range / step size
Digital inputs	Reset digital input by software Set digital input by software Activate external digital input	Off On External
Digital output 1	Reset digital output with software Set digital output with software - Set in case of an error - * Set in case of no error	Off On Error Ready
Digital output 2	Reset digital output with software Set digital output with software Controller mode "Pressure/flow valve open loop" and "Position open loop": The digital output shows, if - Solenoid B is active - * Solenoid B is not active Controller mode "Pressure/flow valve closed loop", "Speed control closed loop", "Position control closed loop" and "Pressure control closed loop 2-sol": The digital output shows, if - Target window reached (when operating without profiles) - a sequence is finished (when operating with profiles, refer to section " Profile-Menu_Sequence " ^[37])	Off On

Field	Parameter description	Range / step size
	<ul style="list-style-type: none"> - * Target window not reached (when operating without profiles) - * a sequence is running (when operating with profiles, refer to section "Profile-Menu Sequence"³⁷) <p>Controller mode "pQ control" and "Alternating control": The digital output shows, if</p> <ul style="list-style-type: none"> - Position target window reached (when operating without profiles) - a sequence is finished (when operating with profiles, refer to section "Profile-Menu Sequence"³⁷) - * Position target window not reached (when operating without profiles) - * a sequence is running (when operating with profiles, refer to section "Profile-Menu Sequence"³⁷) - Pressure target window reached - * Pressure target window not reached - Position or pressure target window reached - * Position or pressure target window not reached - Position and pressure target window reached - * Position and pressure target window not reached 	<p>Solenoid B active Solenoid B not active</p> <p>Inside target window / End of seq</p> <p>Outside target window / Run of seq</p> <p>Inside target window position / End of seq</p> <p>Outside target window position / Run of seq</p> <p>Inside target window pressure Outside target window pressure Inside target window pressure or pressure Outside target window pressure or pressure Inside target window pressure and pressure Outside target window pressure and pressure</p>
Digital output 3	Reset digital output with software Set digital output with software The digital output shows, if <ul style="list-style-type: none"> - control deviation is higher than the trailing window - * control deviation is smaller than the trailing window 	<p>Off On</p> <p>Trailing error No trailing error</p>
Digital output 4	Reset digital output with software Set digital output with software The digital output shows, if <ul style="list-style-type: none"> - a profile is finished - * a profile is running 	<p>Off On</p> <p>Profile end reached Profile end not reached</p>

* This setting is available only with a SD6-electronics with software version > 1.1.1.6 and PASO with software version > 1.5.0.9!

7.8.6 Configuration_Default setting

This menu point is only active in the "On Line"-mode and in the SD6-state "Disabled" (refer to section ["SD6 State machine"](#) ⁽¹¹⁾).

With this command, the default settings made in the factory will be loaded on the connected SD6-Electronics and read to the PC. After successfully read in, the question appears, if the values should be stored on the SD6-Electronics or not.

If "Yes" will be selected, the values will be stored in the way that they are available after the SD6-Electronics will be switched on again (non-volatile memory).

If "No" will be selected, the values are running at the moment, but after the SD6-Electronics will be switched on again, the before current values will be active again.

7.8.7 Configuration_ADC Scaling

In this window the analog/digital converter (ADC) can be scaled.

The ADC scaling was done at the factory. Disruptive change of this setting can lead to malfunction!

Field	Parameter description	Range / Step
Channel	Here the channel for scaling can be selected. Depending on the SD6 card type not all channels are available.	Solenoid output A Solenoid output B Analog input 1 Analog input 2 Analog input 3 Analog input 4 Analog output 1
Internal measured value SD6	This is the value which is measured internally on SD6-electronics. This corresponds to the value which is displayed in the menu " Analysis Values " ^[74] .	
External measured value P1 (Multimeter)	Here must be entered the value witch is external measured with a multimeter. For bipolar signals, only the positive side is considered.	Depending on channel
Take over	The value from the field "Internal measured value SD6" and "External measured value P1 (Multimeter)" is assumed for the calculation.	
External measured value P2 (Multimeter)	Here must be entered the value witch is external measured with a multimeter. For bipolar signals, only the positive side is considered.	Depending on channel
Take over	The value from the field "Internal measured value SD6" and "External measured value P2 (Multimeter)" is assumed for the calculation.	
Calculate	Using the assumed values "Internal measured value SD6" and "External measured value P1 resp. P2 (Multimeter)" the new value for the offset and the amplification of ADC scaling is automatically calculated and sent to the SD6-Electronics. The new calculated values are displayed in the field "Offset" and "Amplification". This button is only active if values were previously assumed.	
Return	The values "External measured value P1 resp. P2 (Multimeter)" are set to 0	
Solenoid current	With the selection "Solenoid current A" resp. "Solenoid current B", the direct operation of the solenoids can be made in this range. ATTENTION: With the direct solenoid operation, the system can move in an uncontrolled way! The settings correspond to the functions in the section " Commands_Valve operation " ^[71] .	

For the ADC scaling, following sequence must be maintained for each channel:

1. Selection of the channel (Field "Channell")
2. Approach the point P1 (should be approx. 10% from the maximum value)
3. Enter the value witch is external measured with a multimeter in the field "External measured value P1 (Multimeter)"
4. Press button "Take over"
5. Approach the point P2 (should be approx. 80% from the maximum value)
6. Enter the value witch is external measured with a multimeter in the field "External measured value P2 (Multimeter)"
7. Press button "Take over"
8. Press button "Calculate". Thus, the new value for the offset and the amplification of ADC scaling is automatically calculated and sent to the SD6-Electronics. If the calculation results an incorrect value, an error message is displayed and the values will not be changed.

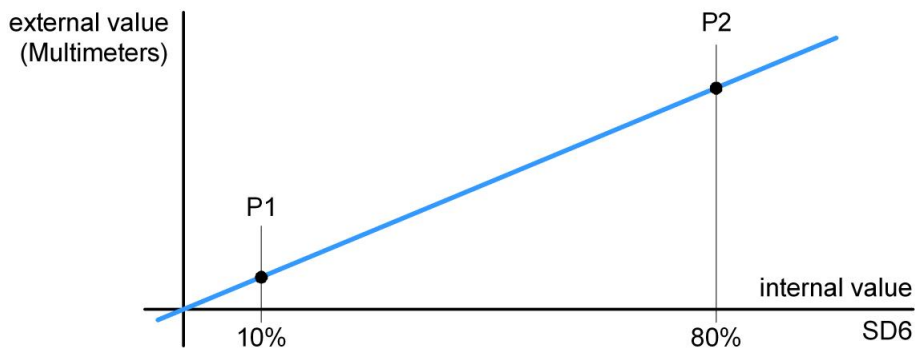

Closing the window without pressing "Calculate" does not change the ADC scaling values.

7.8.8 Configuration_Interface

If a Wandfluh-device with USB interface is connected, by this command the USB parameters will be displayed otherwise an error message will be displayed.

7.8.9 Configuration_Language

In this window, the language can be selected, with which the PASO DSV/SD6 will be inscribed. This setting is automatically saved in the file "konfig.kon" and taken over with a new start.

Field	Parameter description	Range / Step
Language	Field, from which the desired language can be selected.	deutsch english français

7.9 Commands-Menu

In the Commands menu, direct control commands can be transmitted to the SD6-Electronics.

7.9.1 Commands_Command simulation

This setting is available only with a SD6-electronics with software version > 1.1.1.6 and PASO with software version > 1.5.0.9!

This menu point is only active in the "On Line"-mode and if the operating mode is set to "Remote PASO" (refer to section "[Operating mode](#)" ^[12]).

In this window, the input of a command value can be made directly.

It is possible to hold open also the window "Analysis - Values" or "Analysis - Signal recording" at the same time. These can be made with the selection of the menu item "Analysis - Values" or "Analysis - Signal recording" in the menu bar. Thus, the impact of the changed command value can be directly analyzed. If two windows are open, the window "Analysis - Values" resp. "Analysis - Signal recording" must be closed first before even the window "Command simulation" can be closed.

NOTE: Each entry has a direct impact on the system

Field	Parameter description	Range / Step
Enable	The command simulation is enabled The command simulation is disabled (the last active command value is maintained)	Enable Disable
Command value	Desired value of the command value. The value can be adjusted in the selected unit.	Adapted to unit
Speed	After a command value jump the new command value is run-up to over a linear ramp (depending on the speed set). On the actuator this corresponds to a certain travel speed.	0 ... 2000 Step size depends on the scaling
Step	With this value the command value will be added by clicking on the button "Step up" resp. will be subtracted by clicking on the button "Step down".	Adapted to unit
Step up	The command value will be added with the value from "Step"	
Step down	The command value will be subtracted with the value from "Step"	

With the control mode "pQ control (2-sol)" and "Alternating control (2-sol)", the settings can be made for both controllers.

7.9.2 Commands_Valve operation

This menu point is only active in the "On Line"-mode and if the operating mode is set to "Remote PASO" (refer to section "[Operating mode](#)" ^[12]).

In this window, the valve can be directly actuated via the elements available in the window.

It is possible to hold open also the window "Analysis - Values" or "Analysis - Signal recording" at the same time. These can be made with the selection of the menu item "Analysis - Values" or "Analysis - Signal recording" in the menu bar. Thus, the impact of the changed command value can be directly analyzed. If two windows are open, the window "Analysis - Values" resp. "Analysis - Signal recording" must be closed first before even the window "Command simulation" can be closed.

Field	Parameter description	Range / Step
Current	The solenoid current can be command either with the slide control or in the numerical field.	0...100% (Imin...Imax)
Operation	Through this key, the current set can be switched to the solenoid or else the solenoid can be switched to be without current.	Start / Stop
Solenoid change	If a two solenoid valve is available, then with this switch one can changeover between solenoid A and - B.	A / B

7.9.3 Commands_Manual control

This menu point is only active in the "On Line"-mode and if the operating mode is set to "Remote PASO" (refer to section ["Operating mode"](#)^[12]).

In this window, the command value can be incremented or decremented via PASO. Available options are speed in rapid - or creep motion.

It is possible to hold open also the window "Analysis - Values" or "Analysis - Signal recording" at the same time. These can be made with the selection of the menu item "Analysis - Values" or "Analysis - Signal recording" in the menu bar. Thus, the impact of the changed command value can be directly analyzed. If two windows are open, the window "Analysis - Values" resp. "Analysis - Signal recording" must be closed first before even the window "Command simulation" can be closed.

7.9.4 Commands_Local Operating PASO Operating

This menu point is only active in the "On Line"-mode and if the SD6-state is set to "Disabled" (refer to section ["SD6 State machine"](#)^[11]).

If the command "PASO operating" will be activated (only possible if the operating mode is set to "Local"), the SD6-Electronics can be operated direct through the PASO with the commands "Valve operation" and "Enable / Disable". There is no operation through the analogue and digital inputs possible. The operating mode will be changed to "Remote PASO".

If the command "Local operating" will be activated (only possible if the operating mode is set to "Remote PASO"), the SD6-Electronics can be operated through the analogue and digital inputs. A direct valve operation (refer to section ["Commands_Valve operation"](#)^[7]) is not possible. The operating mode will be changed to "Local".

7.9.5 Commands_Disable Enable

This menu point is only active in the "On Line"-mode and if the operating mode is set to "Remote PASO" (refer to section ["Mode of operation"](#)^[2]).

With the command "Enable", the SD6-Electronics will be set to the state "Active" (refer to section ["SD6 State machine"](#)^[11]) and it is generally enabled.

With the command "Disable", the SD6-Electronics will be set to the state "Disabled" (refer to section ["SD6 State machine"](#)^[11]) and it is generally disabled.

7.10 Fieldbus-Menu

In the Fieldbus menu, bus-specific settings can be made.

7.10.1 Fieldbus_Fieldbus Info

If the SD6-Electronics have a fieldbus, with this menu point the necessary bus node adjustments can be made. Also bus states will be displayed here.

If the SD6-Electronics have no fieldbus, the message "The connected SD6-Electronics don't provide an external bus port" will appear.

For more information about the possibilities for the SD6-Electronics with fieldbus, please refer to the document "OPERATING INSTRUCTIONS SD6 PROFIBUS-DP Device-Profile in accordance with Fluid Power Technology".

7.11 Setup mode

In the setup mode menu it is possible to switch on constantly the position or pressure controller.

7.11.1 Setup mode_Setup on / Setup off

This menu point is only visible with controller mode "pQ control (2-sol)" and "Alternating control (2sol)" and is only active in the "On Line"-mode and if the operating mode is set to "Remote PASO" (refer to section "[Operating mode](#)"^[12]).

With "Setup on", the setup mode is switched on. When setup mode is on, it is possible to switch on constantly the position or pressure controller with the menu point "[Setup mode Position](#)"^[73] resp. "[Setup mode Pressure](#)"^[73]. Thus no switching to the other controller is done. This can be used for setting the parameters of the two regulators.

With "Setup off", the setup mode is switched off.

The state of the setup mode is displayed in the status line (setup mode on = setup on, setup mode off = no display).

7.11.2 Setup mode_Position

This menu point is only visible with controller mode "pQ control (2-sol)" and "Alternating control (2sol)" and is only active if the setup mode is switched on (refer to section "[Setup mode Setup on / Setup off](#)"^[73]).

With this command, the position controller is switched on constantly. There is no check to the command pressure. This can be used for setting the parameters of the position controller.

7.11.3 Setup mode_Pressure

This menu point is only visible with controller mode "pQ control (2-sol)" and "Alternating control (2sol)" and is only active if the setup mode is switched on (refer to section "[Setup mode Setup on / Setup off](#)"^[73]).

With this command, the pressure controller is switched on constantly. There is no check to the command position. This can be used for setting the parameters of the pressure controller.

7.12 Analysis-Menu

In the Analysis menu, measured values and possible errors on the SD6-Electronics can be displayed on-line.

7.12.1 Analysis_Values

This menu point is only active in the "On Line" - mode.

With this command, all relevant data of the connected SD6-Electronics are read-in and displayed. The values are continuously updated (on-line).

The following data are displayed with controller mode "Pressure/flow valve open loop", "Pressure/flow valve closed loop (1-sol)", "Position open loop", "Speed control closed loop (2-sol)", "Position control closed loop (2-sol)" and "Pressure control closed loop (2-sol)":

Field	Description	Unit
Signals		
Analog input command	Voltage resp. current value of the command value	V mA
Command value	Scaled command value	Unit set
Analog input feedback	Voltage resp. current value of the feedback value, is only indicated with closed loop controller modes	V mA Inc
Feedback value	Scaled feedback value, is only indicated with closed loop controller modes	Unit set
Control deviation	Scaled control difference, is only indicated with closed loop controller modes	Unit set
Supply voltage	Supply voltage of the SD6-Electronics	V
* Control value	Command value for the solenoid driver	%
Command solenoid current A	Control signal before the solenoid output A .	mA
Solenoid current A	Measured solenoid current to the solenoid A	mA
Command solenoid current B	Control signal before the solenoid output B	mA
Solenoid current B	Measured solenoid current to the solenoid B	mA
Signal analog output	Relative value of the analog output.	%
Analog output	Scaled value of the analog output.	V
Target window reached	Indicates, whether the set target window has been reached (Chapter " Parameter Window " ^[50]).	yes / no
Trailing error	Indicates, whether the trailing error limit has been exceeded (Chapter " Parameter Window " ^[50]).	yes / no
States		
Digital inputs	Logical statuses of the digital input: <ul style="list-style-type: none"> • If the input is set • If the input is not set 	1 0
Digital outputs	Logical statuses of the digital output: <ul style="list-style-type: none"> • If the outputs are set • If the outputs are not set 	1 0

* This value is available only with a SD6-electronics with software version > 1.1.1.6 and PASO with software version > 1.5.0.9!

The following data are displayed with controller mode "pQ control (2-sol)" and "Alternating control (2-sol)":

Field	Description	Unit
Signals		
Input general		
Supply voltage	Supply voltage of the SD6-Electronics	V
Input Position		
Analog input command	Voltage resp. current value of the position command value	V mA
Command value	Scaled position command value	Unit set
Analog input feedback	Voltage resp. current value of the position feedback value, is only indicated with controller mode "Alternating control"	V mA Inc
Feedback value	Scaled position feedback value, is only indicated with controller mode "Alternating control"	Unit set
Control deviation	Scaled control difference, is only indicated with controller mode "Alternating control"	Unit set
Input Pressure		
Analog input command	Voltage resp. current value of the pressure command value	V mA
Command value	Scaled pressure command value	Unit set
Analog input feedback p1	Voltage resp. current value of the pressure feedback (sensor 1)	V mA
Feedback value p1	Scaled pressure feedback value (sensor 1)	Unit set
Analog input feedback p2	Voltage resp. current value of the pressure feedback (sensor 2)	V mA
Feedback value p2	Scaled pressure feedback value (sensor 2)	Unit set
Control deviation	Scaled control difference	Unit set
Feedback value	Scaled pressure feedback value (with "Sensor type = Absolute signal" this corresponds to feedback value p1, with "Sensor type = Differential pressure" this corresponds to the difference value from feedback p1 - feedback p2)	Unit set
Internal signals		
Output position	Output signal from the position controller	%
Output pressure	Output signal from the pressure controller	%
Control value	Command value for the solenoid driver	%
Solenoid outputs		
Command solenoid current A	Control signal before the solenoid output A .	mA
Solenoid current A	Measured solenoid current to the solenoid A	mA
Command solenoid current B	Control signal before the solenoid output B .	mA
Solenoid current B	Measured solenoid current to the solenoid B	mA
Analog output		
Signal Analog output	Relative value of the analog output.	Unit set
Analog output	Scaled value of the analog output.	V
State		
Target window position reached	Indicates, whether the set target window has been reached (Chapter " Parameter Window " ^[50]).	yes / no
Trailing error position	Indicates, whether the trailing error limit has been exceeded (Chapter " Parameter Window " ^[50]).	yes / no
Target window pressure reached	Indicates, whether the set target window has been reached (Chapter " Parameter Window " ^[50]).	yes / no
Trailing error pressure	Indicates, whether the trailing error limit has been exceeded (Chapter " Parameter Window " ^[50]).	yes / no
Pressure control active	Indicates, whether the position or the pressure controller is active	yes = pressure no = position
States		

Digital inputs	Logical statuses of the digital input: <ul style="list-style-type: none"> • If the input is set • If the input is not set 	1 0
Digital outputs	Logical statuses of the digital output: <ul style="list-style-type: none"> • If the outputs are set • If the outputs are not set 	1 0

7.12.2 Analysis_Signal Recording

In the menu "Analysis_Signal recording", various signals of the connected SD6-Electronics can be recorded and analysed.

The selection of the data to be recorded takes place in the menu "Signal assignment", which is selected through the key "Signal assignment". In the "Off - mode" it is not possible to record signals, it is possible, however, to process the recording parameters (menu "Signal assignment").

As a standard, it is possible to record up to 250 measuring values per measuring channel (maximum 4 channels). The maximum recording duration of the recording can be derived from the scanning rate set multiplied with the number of the measuring values. The scanning rate as a minimum amounts to 4ms. Because the first measured value is recorded at the point in time zero (start), the last measurement is situated one scanning step before the end of the measuring duration.

The recording parameters (signal type, scanning rate, etc.) together with the parameters are saved on the card and when saving to a file they are saved on the hard-disk.

The recorded measuring values are **not** saved with the parameters. However, there is the possibility of exporting the recorded measuring values (key "Export").

With the help of the time cursor, the measuring values are displayed for every point in time.

When changing the mode "On-Line / Off-Line" and when terminating the PASO, the recorded measuring values are lost.

Field	Parameter description
Signal display	Switching-on the fields makes the recorded curve of the respective channel visible.
Time cursor	Positioning the time cursor over the input field time [s] or with the help of the slider control underneath the graphics.
Signal assignment	Opens the menu signal assignment (see below).
New	Any recorder data are deleted and the card is ready for a new recording.
Start / Stop	<p>Start A new recording is started. As soon as the trigger is actuated, the recording runs (apparent by the blinking of the field "Recording") and the measuring data are transmitted. If there are already measuring data in the memory, then the recording continues as from this point. Once the maximum number of measuring values has been read-in, the possible remaining recording data are transmitted (the curves continue to be updated). During the transmission, it is already possible to analyse the curves ("Signal display", "Auto-scaling").</p> <p>Stop Stops the transmission and the recording. As from this point it is possible to record once again by a renewed actuation of Start. Once the maximum number of measuring values has been read-in, or in the case of "Off-Line operation", the Start key is dimmed.</p>
Export	<p>By the actuation of this key the recorded data are saved on the hard-disk. The format used is a text format with tabulators as separators, so that it is easily possible to import the values into a different program (e.g. Excel). The decimal marker of the numbers can be selected: Decimal point or comma.</p>

Field	Parameter description
Auto-scaling	With this key, the curves are displayed in the graphics in an optimum manner. The optimisation is only carried out for the inserted curves. The values "Scaling/Div" and "Offset" of the corresponding channels (" Signal assignment  "), are adapted for this purpose. The auto-scaling is also operative during a recording.
Closing	With this key, one leaves the signal recording menu. Any recording data are kept and these are displayed once more by a renewed selection of the menu.

Menu Signal Assignment

This menu is opened by the actuation of the key "Signal assignment" in the Signal Recording window. In this menu, you can select which signals you would like to record.

1. Up to four recording channels are available and can be activated for the recording.
2. Under "Signal" you can select, which type of signal you would like to record.
3. Under "Trigger" you can select the channel, on which triggering takes place, as well as the triggering flank and the triggering level.
4. Under "Sample Time", the scanning rate is defined (0.004...60 s, a multiple of 4ms).
5. The display of the recording curves is defined by "Scaling/Div" and "Offset".
6. Leaving the menu with OK:
If changes under 1-5 have been made, then any possible recording data (together with the graphics) are deleted.
7. Leaving the menu with Cancel:
Any possible changes are cancelled again.

The display parameters "Scaling/Div" and "Offset" are saved on the card together with the parameters.

HINT: The signal "Solenoid current A/B" is averaged over one dither-period (even when setting the dither-amplitude to 0). This causes a "staircase effect" in the signal recording at low dither-frequencies. The real solenoid current does not showing this effect!

7.12.3 Analysis_Diagnostics

With this command, possibly present errors on the connected SD6-Electronics are indicated. The error is read in once. A complete description of the error will be displayed.

In the status line of the main window it will be displayed if an error is present (State: Error) or not (State: Ready).

The red LED on the SD6-Electronics will blink in accordance with the current error.

Diagnostics:	Error	Error remedy	Blink code
Power supply fault	If the supplied voltage < 18VDC. The solenoid outputs are blocked.	Disable and reenale the control	1 x
Cable break input 2	This error is only detected, if the parameter "cablebreak" is set to "yes" and the parameter "signal type" is set to "4...20 mA". The solenoid outputs are blocked.	Disable and reenale the control	2 x
Short circuit solenoid output	There is a short circuit on the solenoid output	Disable and reenale the control	3 x
Memory error	There is an internal memory error on the SD6-Electronics	Switch off and switch on again the control	4 x

7.13 Help-Menu

The PASO DSV/SD6-Help based on the standard Windows-Help construction.

With the button "Help" in each window, the corresponding help text will be displayed.

7.13.1 Help_Description of the function

A general information about the function of the SD6-Electronics will be displayed.

7.13.2 Help_Contents

The list of contents of the PASO DSV/SD6-Help will be displayed. By clicking on the desired subject, the corresponding help text will be displayed.

7.13.3 Help_Index

The list of index of the PASO DSV/SD6-Help will be displayed. With entering a search item, all subject corresponding to the search item will be listed.

7.13.4 Help_SD6 Identification

This menu point is only active in the "On Line"-mode.

Here the current version of the hardware and the software from the connected SD6-Electronics will be read and displayed.

7.13.5 Help_WANDFLUH on the Web

A link to the WANDFLUH home page.

7.13.6 Help_Info

Information about PASO DSV/SD6 and its version.

8 System does not work

In this section, the generally possible errors and the procedures for eliminating them are listed and explained.

8.1 Procedure

The following check list can be used to help, if a problem is arised.

Question:	Action:	Possible errors and causes	Blink code
State: Error	Analysis_Diagnos tics Power supply error	<ul style="list-style-type: none"> The supplied voltage is under 18VDC. The error is also displayed if a supplied voltage interruption occurred (t > 250ms). Is the supplied power sufficient? Is the AC voltage too high (refer to section "Electrical specifications" 5) When the error is cleared, disable the controller for a short period and re-enable (Digital Input 1) 	1 x
	Analysis_Diagnos tics Cable break input	<ul style="list-style-type: none"> The cable break detection functions only with 4 ... 20mA command value. The command value signal is absent or is smaller than 3mA. Check the command value signal connections between the command value encoder and SD6-Electronics. If the cablebreak detection is not desired, switch off the cablebreak function in the menu "Configuration". When the error is cleared, disable the controller for a short period and re-enable. 	2 x
	Analysis_Diagnos tics Short circuit solenoid output	<ul style="list-style-type: none"> There is a short circuit on the solenoid output When the error is cleared, disable the controller for a short period and re-enable. 	3 x

9 PASO DSV/SD6 Installation and Operation

The parameterisation software PASO DSV/SD6 serves for the parameterising and diagnosing of all Electronic cards SD6 of the WANDFLUH AG company. The software provides a user interface, through which by means of a keyboard or a mouse all adjustments and settings can easily be carried out. The communication with the digital card takes place through a USB-interface.

The parameterisation software PASO DSV/SD6 can only be utilised in connection with a SD6-Electronics of the WANDFLUH AG company.

9.1 System presupposition

A description of the different PASO versions is located in the file "history.pdf". This file is located in the directory where the PASO will be installed.

In order to be able to correctly utilise the PASO, an IBM-compatible PC with the following requirements has to be available:

- Processor 486 or higher, min. 33MHz, min. 8MB RAM
Recommended: 80586 66MHz or higher, 16 MB RAM or more
- Free harddisk storage space of minimum 4MB, plus storage space for program files
- Operating system Windows 2000 or Windows XP (Windows Vista on request)
- Standard VGA or higher graphics card, recommended resolution 800x600
- At least one USB interface (USB 1.1 or USB 2.0)
- USB cable type A => B, male/male

9.2 Installation

The PASO software can be downloaded via the Internet free of charge (www.wandfluh.com/Download => PASO DSV/SD6 => Download Program files) or on request delivered on an installation-CD.

The installation of the PASO is then carried out by executing the file "setupPasoDSVvxxxx.exe", where "xxxx" means the current version (e.g. setupPasoDSVv1000.exe, see also version index). An installation program takes over the complete installation of PASO. To them, the Windows Installer must be installed. This is normally a part of the Windows Environment. If not, please download it from the Microsoft Website.

If there is already a version of the PASO software installed on the PC, one can select if the existing version should be overwritten or removed.

The helpfiles are included in the setup and are installed automatically.

9.3 Connection to the Wandfluh card

The connection between the PC, on which the parameterisation software PASO DSV/SD6 is installed, and the SD6-Electronics takes place through the USB interface. To do this, a USB cable type A => B, male/male has to be connected with the desired USB port on the PC and with the USB socket on the SD6-Electronics.

During the installation of the parameterisation software PASO DSV/SD6, the used USB driver for the SD6-Electronics will be installed automatically. A new installation of this driver is possible. In the directory, where the parameterisation software PASO DSV/SD6 is installed, there is a sub directory "USB_Driver". In this sub directory, there is a file "PreInstaller.exe". With executing this file, the installation of the USB driver is possible.

If the USB driver for the SD6-Electronics is installed correctly, it must be shown in the Windows Devicemanager in the "USB-Controller" as "Wandfluh AG - SD6" while a SD6-Electronics is connected to the PC.

Hint: The USB driver is not Windows certificated. Therefore a Windows warning message appears during installation with Windows XP. Please click "install" to continue installation. The PC will not be

damaged. The same warning message appears by connecting a SD6-Electronics to the PC the first time. In this case please click "install". Both warning messages appear only with Windows XP. They do not appear with Windows 2000.

9.4 Mode "Off Line" and "On Line"

The parameterisation software PASO DSV/SD6 runs in one of two modes:

- In the **"Off Line"-mode**, the processing of the parameter files is possible. This has no influence in a possible connected Wandfluh-Electronics. The communication with the Wandfluh-Electronics is not active. A connection is allowed, but not necessary.

All menu points and keys, which involve an action in connection with the communication, are then blocked.

- In the **"On Line"-mode**, there is active communication with the Wandfluh-Electronics. Every change becomes immediately effective in the Wandfluh-Electronics. In this mode, the loading and processing of files is not possible. Only the saving of the currently active parameters to a file is possible.

There is permanent communication between the PASO DSV/SD6 and the connected Wandfluh-Electronics.

Because of that, it is not allowed to disconnect the connection to the Wandfluh-Electronics or to switch off the Wandfluh-Electronics in the "On Line"-mode.

The change between the two modes takes place through the menu point "File_Activate On Line / Activate Off Line". Near it, it's possible to select if the data should take over from the Wandfluh-Electronics (data flow Wandfluh-Electronics => PASO) or if the Wandfluh-Electronics should be reprogrammed with the new actual data (data flow PASO => Wandfluh-Electronics).

In case of an interference in the communication, the controlling of the Wandfluh-Electronics is not assured anymore. An error message follows and the PASO DSV/SD6 software automatically changes over to the "Off Line"-mode (refer to section ["Communication interruption"](#) (83)).

9.5 Communication start up

When the parameterisation software PASO DSV/SD6 is started up, a check takes place, as to whether a communication with the Wandfluh-Electronics is possible. If no communication can be established, an error message appears (refer to section ["Communication interruption"](#) (83)). If a communication with the connected card is possible, a check will be made, whether the current configuration of the PASO DSV/SD6 corresponds to the configuration of the connected Wandfluh-Electronics. If yes, the parameters will be transferred from the Wandfluh-Electronics to the PASO DSV/SD6. If no, a message will be displayed and the current configuration from the PASO DSV/SD6 will change automatically over to the new configuration and the parameters will be transferred from the Wandfluh-Electronics to the PASO DSV/SD6.

If several Wandfluh-Electronic devices are connected via the USB-Interface, the following window appears:

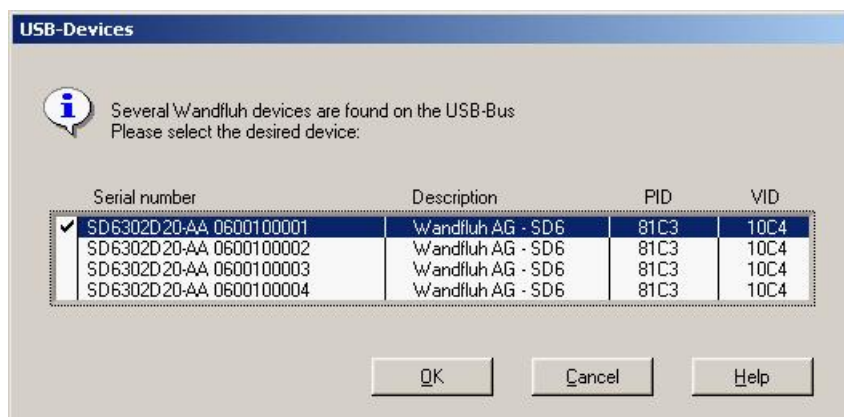

Here, the desired device for the communication start up can be selected.

9.6 Communication interruption

If no communication is possible during the start up or the interruption of the communication occurs during the operation of the parameterisation software PASO DSV/SD6, then an error message appears and the PASO DSV/SD6 software is set to the "Off Line"-mode. All menu points and keys, which involve an action in connection with the communication, are now blocked. In order to re-establish a communication, the menu point "File_Activate On Line" has to be selected.

Possible reasons for no communication is possible during the start up are:

- **Wrong Device type**

The device type must be SD6. The picture in the PASO must be as follows:



If there is another picture, go through the following steps:

- Menu "[File - New](#)³⁴" (only possible in the OFF-Line mode)
- "Would you like to retain the current configuration?" say "No"
- Select device type "SD6" => "OK"
- Select the desired function => "OK"
- Select the desired number of solenoid => "OK"

- **No device connected**

In the menu "[Configuration - Interface](#)⁷⁰", you can see the following items:

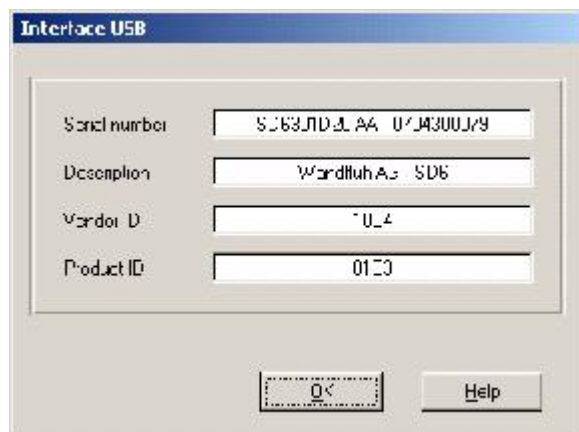

You can see these items also in the OFF-Line mode and without power supply on the SD6 card. If these items are not visible, there is a problem with the USB driver or with the USB connection. To check the USB driver, go through the following steps:

- Select in the Windows "Start - System - Hardware - Device Manager"
- In the item "USB-Controller" the entry "Wandfluh AG - SD6" must be written
- If this entry is missing, no USB connection to the SD6 card is available => check the USB cable
- If the entry "Wandfluh AG - SD6" is marked with a yellow mark, double click on it and reinstall the driver
- If you have to look for a driver, the directory is "location\PasoDSVSD6v...\USB_Driver" (the location is the directory where the PASO is installed)

To check the USB connection, go through the following steps:

- take out the USB cable
- wait 10s
- reconnect the USB cable

• SD6 card not supplied

If step 1 and 2 are ok, but there is still no communication possible, be sure that the SD6 card is supplied with supply voltage.

9.7 Program description

9.7.1 Description of the keys

TAB	Transfer to the next input element
SHIFT-TAB	Transfer to the previous input element
ENTER	Execution of the active input element or conclusion of an input.
ESC	Abort, undoing of an action. In many cases corresponds to the key "Cancel".
F1	Activate the key "Help"

9.7.2 Input elements

Key	<p>A key executes the action, with which it is inscribed.</p> <p>Actuation of a key through the keyboard:</p> <ul style="list-style-type: none"> • Push the key TAB, until the key becomes active. • Push the key ENTER. The action is now carried out. • Push the key ALT and the underlined letter of the key inscription: The action is carried out immediately.
-----	--

	<p>Actuation of a key with the mouse:</p> <ul style="list-style-type: none"> • Click on the corresponding key. The action is now carried out.
Switch	<p>By means of a switch, a selection between two possibilities is possible. A switch is either switched on or - off.</p> <p>Actuation of a switch through the keyboard:</p> <ul style="list-style-type: none"> • Push the keys UP or HOME to switch on the switch. • Push the keys DOWN or END to switch off the switch. • Push the SPACE key for changing over (switching over). <p>Actuation of a switch with the mouse:</p> <ul style="list-style-type: none"> • Click on the switch for changing over (switching over).
Input field	<p>The input fields enable the entering of numbers or text. All applicable keys of the keyboard are allowed, including the keys HOME, END, LEFT, RIGHT. In certain cases when taking it over, the input is checked and if necessary an error message is issued.</p> <p>Actuation of an input field through the keyboard:</p> <ul style="list-style-type: none"> • Push the key ENTER or TAB to finish with the input field. • In the case of input fields with ARROW keys UP and DOWN: Actuation of the UP-/DOWN - keys for the step by step changing of the values. <p>Actuation of an input field with the mouse:</p> <ul style="list-style-type: none"> • Click within the input field, in order to position the cursor in it. • In the case of input fields with ARROW keys UP and DOWN: Click on the corresponding arrow for the step by step changing of the values.
Selection field	<p>The selection fields enable the selection from various possibilities.</p> <p>Actuation of a selection field through the keyboard:</p> <ul style="list-style-type: none"> • Push the SPACE key to open all selection possibilities. With the help of the keys UP, DOWN, HOME, END, make the required selection. Subsequently push the ENTER key to confirm the required selection, or else the ESC key to undo the selection. • Push the key UP to cyclically select the previous selection. • Push the key DOWN to cyclically select the next selection. • Push the key HOME to select the first item of the selection list. • Push the key END to select the last item of the selection list. <p>Actuation of a selection field with the mouse:</p> <ul style="list-style-type: none"> • Click inside the selection field so that all selection possibilities are displayed and then click on the required selection.

9.8 Starting of PASO DSV/SD6

Following the successful installation, the parameterisation software PASO DSV/SD6 can be started by double-clicking on the PASO DSV/SD6 - icon. Certain settings of the PASO DSV/SD6 software, e.g., the selected interface port, are saved in the file "konfig.kon". When PASO DSV/SD6 is started for the first time, the configuration values in this file are set to standard values. During the course of running the program, these values can be corrected.

After the start-up, the Start window appears:



During the start-up, the parameterisation software PASO DSV/SD6 checks, whether a Wandfluh-Electronics device is connected. If no communication can be established, an error message appears (refer to section ["Communication interruption"](#)^[83]) and the "Off Line"-mode will become active. All menu points and keys, which involve an action in connection with the communication, are then blocked. All other functions of the parameterisation software PASO DSV/SD6 can be utilised without any limitation.

If the communication works without any interference, the software PASO DSV/SD6 checks, whether the current configuration of the PASO DSV/SD6 corresponds with the configuration of the connected digital controller card. If no, a message will be displayed and the current configuration from the PASO DSV/SD6 will change automatically over to the new configuration

Subsequently the parameters are loaded from the card and subsequently a verification of the Wandfluh-Electronics values takes place. If one or several parameters are outside the corresponding tolerance, they are replaced with standard values and a message is issued (refer so section ["Limiting value error"](#)^[87]). The changed parameters can be either sent directly to the connected Wandfluh-Electronics or the communication start-up can be terminated (the "Off-Line"-mode will become active). In the latter case the user has the possibility to correct the parameters in "Off-Line"-mode. The communication is resumed again via the menu point "File_Activate On Line". Subsequently the user has to select the option "Reprogram the Wandfluh-Electronics", in order for the corrected values to be made active on the Wandfluh-Electronics.

The menu points in the menu line can be selected in the following manner:

- by clicking on them with the mouse
- by actuating the key "ALT" and the underlined letter of the required menu point
- if a menu point has been selected, then by means of the keys "←" and "→" one can change to the next menu point and with the keys "↑" and "↓" one can change to the next sub-menu point within the menu selection field.
- by clicking on the corresponding icon in the icon list

In the header line of the window, the name of the current file is always displayed. If no existing file has been loaded or if the data have not been saved to a file, then this line reads "noname".

The following states will be displayed in the status line:

PASO state:

- 1st field: Selected interface ("USB")
- 2nd field: Current mode ("On Line" or "Off Line", refer to section ["Mode "Off Line" and "On Line"](#))

Device state:

- 1st field: Operating mode ("Remote PASO" or "Local", refer to section ["Mode of operation"](#))
- 2nd field: Characteristic optimisation ("KL-Optimierung", refer to section ["Characteristic optimisation"](#))
- 3rd field: Mode of operation ("Remote PASO" or "Local", refer to section ["Mode of operation"](#))
- 4th field: Setup mode ("Setup mode", refer to section ["Setup mode"](#))
- 5th field: SD6 state ("Disabled" or "Active", refer to section ["SD6 State machine"](#))
- 6th field: Error state (Ready or Error, refer to section ["Analysis Diagnostic"](#))

9.9 Store parameter

Each new input value is immediately transferred to the connected Wandfluh-Electronics after the completion of the input field (either by pushing the key ENTER or by activating another input field).

If the window is closed with the key "OK", the values are stored in the Wandfluh-Electronics so that they are available after the Wandfluh-Electronics are switched on again (non-volatile memory).

If the window is closed with the key "Cancel", the previous current values are active again. All inputs made in the current window are cancelled.

9.10 Limiting value error

Each incoming parameter (either transferred via the serial interface or loaded from a file) is checked against the limiting value. If a parameter is smaller or bigger than its limiting value (= limiting value error), it is set automatically to the default value and the following window appears:

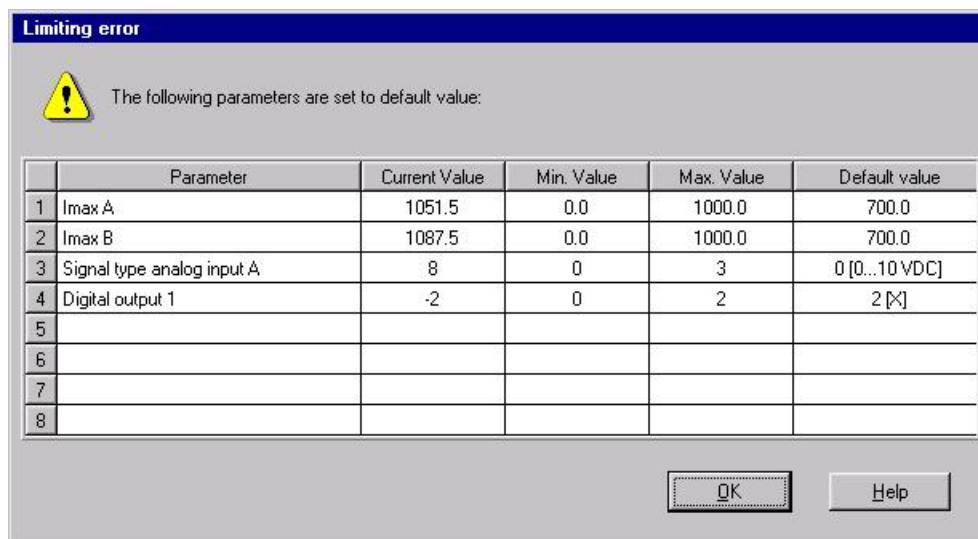

Parameter: Name of the parameter with the limiting value error
Current value: Current value of the parameter
Min. value: Minimum allowed value of the parameter
Max. value: Maximum allowed value of the parameter
Default value: Default value of the parameter

After pressing the key "OK", the current value is overwritten by the default value.

Normally, a limiting value error does not happen. However, in the following cases it can happen:

- loading a file, in which parameter values have been changed from outside
- reading parameter values from a Wandfluh-Electronics device with another configuration than the current configuration in the PASO (only if the Wandfluh-Electronics were changed while in the "On Line"-mode)
- if the transmission of the parameter values is wrong

9.11 Description of Commands

The description of the individual commands and parameters is contained in section ["Settings"](#)¹⁰.

10 Disposal

- The SD6-Electronics have to be disposed of in accordance with the generally applicable regulations of that country, in which it is being used.
- Electronics components are recycled by companies specialised in this field.

11 Additional information

You can find additional information in the following Wandfluh documentations:

Wandfluh-Electronics general	Documentation A	Register	1.13
Accessories	Documentation A	Register	1.13
Proportional directional control valves	Documentation A	Register	1.10
Proportional pressure control valves	Documentation A	Register	2.3
Proportional flow control valves	Documentation A	Register	2.6