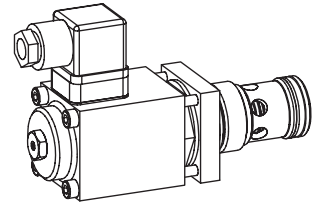

**Proportional 2-way flow control valve
Screw-in cartridge**

- Direct operated, pressure compensated
- $Q_{max} = 63 \text{ l/min}$, $p_{max} = 350 \text{ bar}$
- $Q_{Nmax} = 63 \text{ l/min}$

M33x2
 ISO 7789

DESCRIPTION

Direct operated, pressure compensated proportional flow control valve, as a screw-in cartridge with a thread M33x2 for cavity acc. to ISO 7789. Two flow ranges are available. The volume flow is adjusted by a Wandfluh proportional solenoid (VDE standard 0580). Almost linear flow increase and low hysteresis are typical for this valve. The cartridge body made of steel is special surface coated for corrosion rust protection and low friction of control- and throttle spools. The solenoid is zinc coated.

FUNCTION

The 2-way flow control valve is designed to keep the oil flow to any actuator constant irrespective of the load. The force controlled proportional solenoid running in the fluid acts directly on the restrictor spool which opens the throttling notches in the cartridge body. The throttle opening, and therefore the flow volume changes proportionally to the current absorption of the proportional solenoid. If pressure in the system changes the pressure compensator will change the area of the oil passage to an extend as to keep the pressure drop over the restrictor constant. When the solenoid is without current, the restrictor spool is held in the closed position by a spring. To control the valve Wandfluh proportional amplifiers are available (see register 1.13).

APPLICATION

Proportional flow control valves are suitable for precise feed control system where the supply volume flow needs to be kept constant even when the load fluctuates. The screw-in cartridge is very suitable for mounting in control blocks, flange bodies and sandwich plates size NG10. Stepped tools are available for making the receptacle bores in steel and aluminium (hire or purchase). Please refer to the data sheets in register 2.13.

CONTENTS

GENERAL SPECIFICATIONS	1
HYDRAULIC SPECIFICATIONS	1
ELECTRIC SPECIFICATIONS	1
SYMBOLS	1
CHARACTERISTICS	2
DIMENSIONS/ SECTIONAL DRAWINGS	2
PARTS LIST	2
ACCESSORIES	2

TYPE CODE

	Q	N	P	PM33	-		-		#	
Flow control valve										
Normally closed										
Proportional										
Screw-in cartridge M33x2										
Nominal volume flow rates Q_N :	32 l/min	32								
	63 l/min	63								
Standard nominal voltage U_N :	12 VDC					G12				
	24 VDC					G24				
Design-Index (Subject to change)										

GENERAL SPECIFICATIONS

Description	2-way proportional flow control valve
Construction	Screw-in cartridge for cavity acc. to ISO 7789
Operations	Proportional solenoid
Mounting	Screw-in thread M33x2
Ambient temperature	-20...+50 °C
Mounting position	any
Fastening torque	$M_D = 80 \text{ Nm}$ for screw-in cartridge $M_D = 5,2 \text{ Nm}$ (Qual. 8.8) for solenoid screws
Weight	$m = 1,2 \text{ kg}$
Flow direction	1 → 2

HYDRAULIC SPECIFICATIONS

Fluid	Mineral oil, other fluid on request
Contamination efficiency	ISO 4406:1999, class 18/16/13 (Required filtration grade $\beta_{6...10} \geq 75$) see data sheet 1.0-50/2
Viscosity range	12 mm ² /s...320 mm ² /s
Fluid temperature	-20...+70 °C
Peak pressure	$p_{max} = 350 \text{ bar}$
Nominal volume flow	$Q_N = 32 \text{ l/min}$, 63 l/min
Max. Volume flow	$Q_{max} = 63 \text{ l/min}$
Min. Volume flow	$Q_{min} = 0,2 \text{ l/min}$
Leakage volume flow	see characteristics
Repeatability	≤ 2 % *
Hysteresis	≤ 5 % *
	* at optimal dither signal

ELECTRICAL SPECIFICATIONS

Construction	Proportional solenoid, wet pin push type, pressure tight	
Standard nominal voltage	U = 12 VDC	U = 24 VDC
Limiting current	$I_G = 1780 \text{ mA}$	$I_G = 810 \text{ mA}$
Relative duty factor	100 % ED (see data sheet 1.1-430)	
Protection class	IP 65 acc. to EN 60 529	
Connection/	Over device plug connection to	
Power supply	ISO 4400 / DIN 43650, (2P+E)	
Other electrical specifications	see data sheet 1.1-130 (PI45V)	

SYMBOLS

simplified

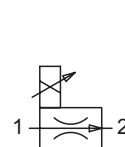

detailed

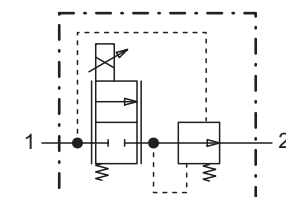

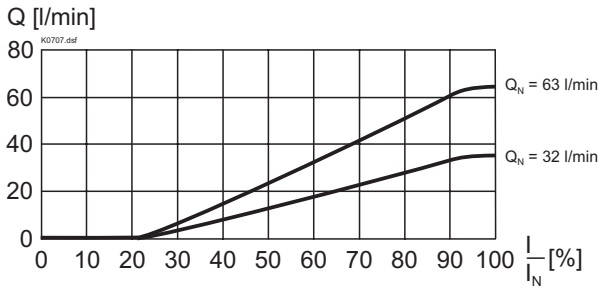
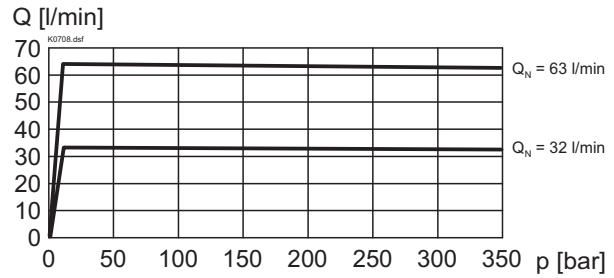
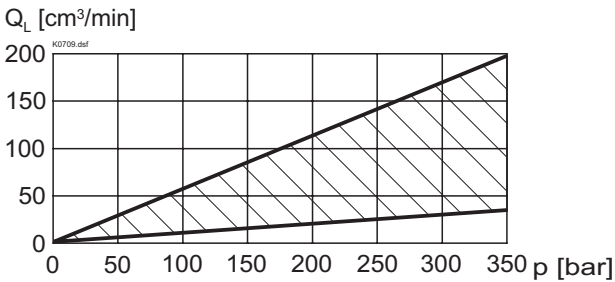
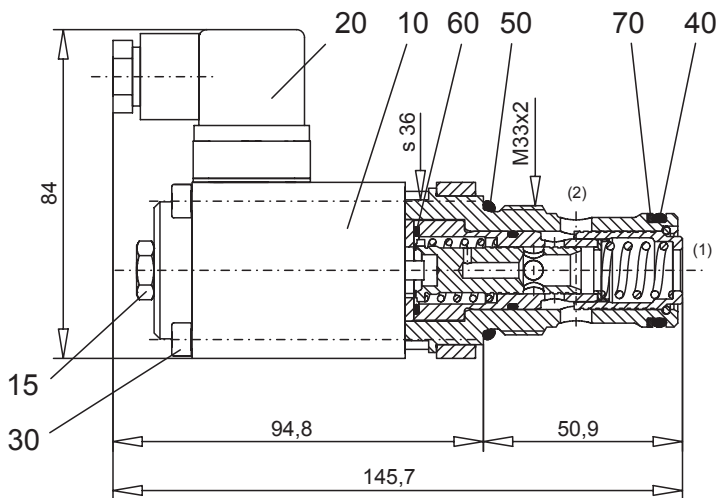
CHARACTERISTICS Oil viscosity $\nu = 30\text{mm}^2/\text{s}$
 $Q = f(I)$ Volume flow adjustment characteristics

 $Q = f(p)$ Volume flow pressure characteristics

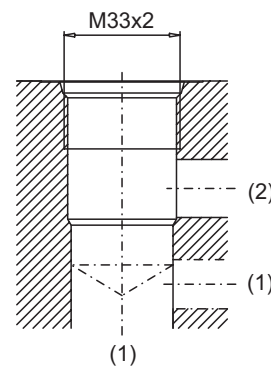
 $Q_L = f(p)$ Leakage volume flow characteristics

DIMENSIONS / SECTIONAL DRAWINGS

Cavity drawing acc. to ISO7789-33-01-0-98



For detailed cavity drawing and cavity tools see data sheet 2.13-1005.

PARTS LIST

Position	Article	Description
10	256.4454 256.4418	Proportional solenoid PI45V-G24 Proportional solenoid PI45V-G12
15	253.8001	Plug with integrated manual override HB6
20	219.2002	Plug (black)
30	246.2171	Cyl. screw M5x70 DIN 912
40	160.2238	O-ring ID 23,81x2,62
50	160.2298	O-ring ID 29,82x2,62
60	160.2188	O-ring ID 18,77x1,78
70	049.3297	Back-up ring RD 24,5x29x1,4

ACCESSORIES

Proportional amplifier

Register 1.13

Technical explanation see data sheet 1.0-100