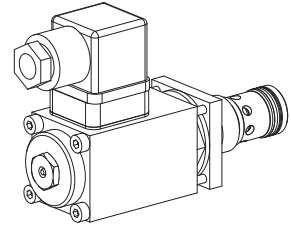

**Proportional 2-way flow control valve
Screw-in cartridge**

- Direct operated, pressure compensated
- $Q_{max} = 25 \text{ l/min}$, $p_{max} = 350 \text{ bar}$
- $Q_{Nmax} = 25 \text{ l/min}$

M22x1,5
 ISO 7789

DESCRIPTION

Direct operated, pressure compensated proportional flow control valve, as a screw-in cartridge with a thread M22 x 1,5 for cavity acc. to ISO 7789. Four flow ranges are available. The volume flow is adjusted by a Wandfluh proportional solenoid (VDE standard 0580). The cartridge body made of steel is special surface coated for corrosion rust protection and low friction of control- and throttle spools. The solenoid is zinc coated.

FUNCTION

The 2-way flow control valve is designed to keep the oil flow to any actuator constant irrespective of the load. The force controlled proportional solenoid running in the fluid acts directly on the restrictor spool which opens the throttling notches in the cartridge body. The throttle opening, and therefore the flow volume changes proportionally to the current absorption of the proportional solenoid. If pressure in the system changes the pressure compensator will change the area of the oil passage to an extent as to keep the pressure drop over the restrictor constant. When the solenoid is with-out current, the restrictor spool is held in the closed position by a spring. To control the valve Wandfluh proportional amplifiers are available (see register 1.13).

APPLICATION

Proportional flow control valves are suitable for precise feed control system where the supply volume flow needs to be kept constant even when the load fluctuates. The screw-in cartridge is very suitable for mounting in control blocks, flange bodys and sandwich. Stepped tools are available for making the receptacle bores in steel and aluminium (hire or purchase). Please refer to the data sheets in register 2.13.

CONTENTS

GENERAL SPECIFICATIONS.....	1
HYDRAULIC SPECIFICATIONS	1
ELECTRIC SPECIFICATIONS	1
SYMBOLS	1
CHARACTERISTICS.....	2
DIMENSIONS/SECTIONAL DRAWINGS.....	2
PARTS LIST	2
ACCESSORIES.....	2

TYPE CODE

	Q	N	P	PM22	-		-		#	
Flow control valve										
Normally closed										
Proportional										
Screw-in cartridge M22x1,5										
Nominal volume flow rates Q_N :	3,2 l/min									
	8 l/min									
	18 l/min									
	25 l/min									
Standard nominal voltage U_N :	12 VDC									
	24 VDC									

Design-Index (Subject to change)

GENERAL SPECIFICATIONS

Description	2-way proportional flow control valve
Construction	Screw-in cartridge for cavity acc. to ISO 7789
Operations	Proportional solenoid
Mounting	Screw-in thread M22x1,5
Ambient temperature	-20...50 °C
Mounting position	any
Fastening torque	$M_D = 50 \text{ Nm}$ for screw-in cartridge $M_D = 2,8 \text{ Nm}$ (Qual. 8.8) for solenoid screws
Weight	$m = 0,64 \text{ kg}$
Flow direction	1 → 2

HYDRAULIC SPECIFICATIONS

Fluid	Mineral oil, other fluid on request
Contamination efficiency	ISO 4406:1999, class 18/16/13 Required filtration grade ($\beta_{6...10} \geq 75$) (see data sheet 1.0-50)
Viscosity range	12 mm ² /s...320 mm ² /s
Fluid temperature	-20...+70 °C
Peak pressure	$p_{max} = 350 \text{ bar}$
Nominal volume flow	$Q_N = 3,2/8/18/25 \text{ l/min}$
Max. Volume flow	$Q_{max} = 25 \text{ l/min}$
Min. Volume flow	$Q_{min} = 0,1 \text{ l/min}$
Leakage volume flow	see characteristics
Repeatability	≤ 2 %*
Hysteresis	≤ 5 %*

* at optimal dither signal

ELECTRICAL SPECIFICATIONS

Construction	Proportional solenoid, wet pin push type, pressure tight	
Standard nominal voltage	U = 12 VDC	U = 24 VDC
Limiting current	$I_G = 1250 \text{ mA}$	$I_G = 680 \text{ mA}$
Relative duty factor	100% ED (see data sheet 1.1-430)	
Protection class	IP 65 acc. to EN 60 529	
Connection/	Over device plug connection acc. to	
Power supply	ISO 4400 / DIN 43650 (2P+E)	
Other electrical specifications	see data sheet 1.1-117 (PI35V)	

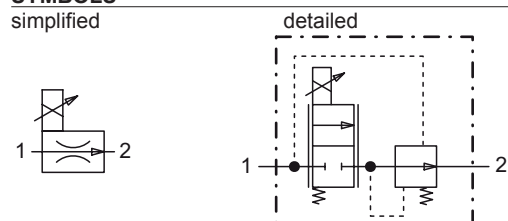
SYMBOLS

CHARACTERISTICS Oil viscosity $\nu = 30 \text{ mm}^2/\text{s}$
 $Q = f(I)$ Volume flow adjustment characteristics

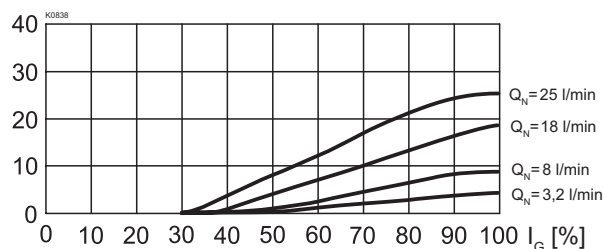
 Q [l/min]

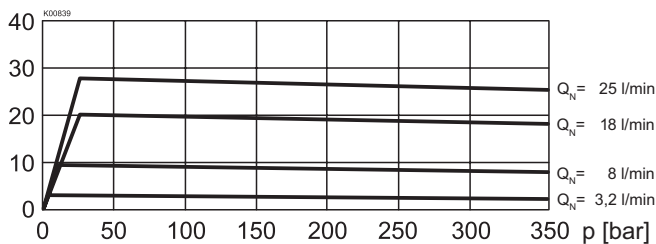
 $Q = f(p)$ Volume flow pressure characteristics

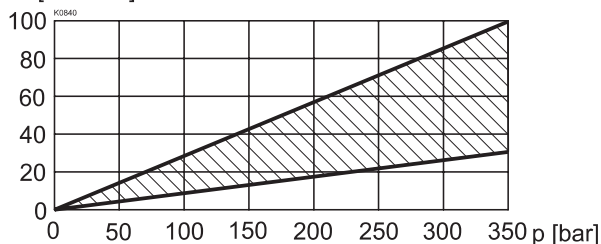
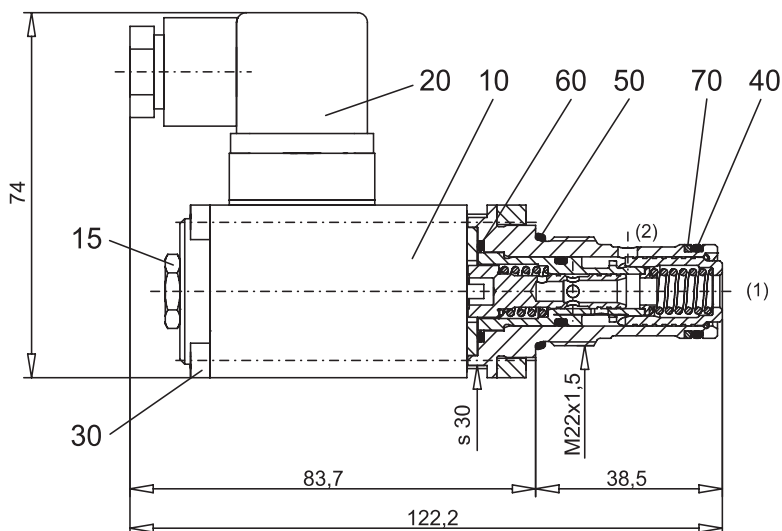
 Q [l/min]

 $Q = f(p)$ Leakage volume flow characteristics

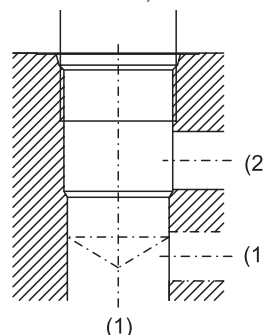
 Q [cm³/min]

DIMENSIONS / SECTIONAL DRAWINGS

 Cavity drawing acc. to
 ISO 7789-22-01-0-98

M22x1,5

 For detailed cavity drawing
 and cavity tools see data
 sheet 2.13-1008

PARTS LIST

Position	Article	Description
10	256.3454 256.3426	Proportional solenoid PI35V-G24 Proportional solenoid PI35V-G12
15	253.8000	Plug with integrated manual override HB4,5
20	219.2002	Plug (black)
30	246.1166	Cyl. screw M4x65 DIN 912
40	160.2156	O-ring ID 15,60x1,78
50	160.2188	O-ring ID 18,77x1,78
60	160.2170	O-ring ID 17,17x1,78
70	049.3191	Back-up ring RD 16,1x19x1,4

ACCESSORIES

Proportional amplifier

Register 1.13

Technical explanation see data sheet 1.0-100D