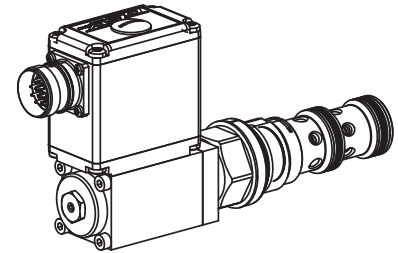

**Proportional pressure reducing valve
Screw-in cartridge**

- Integrated electronics
- Pilot operated
- $Q_{max} = 160 \text{ l/min}$
- $p_{max} = 400 \text{ bar}$
- $p_{N \text{ red max}} = 350 \text{ bar}$

M33x2
 ISO 7789

DESCRIPTION

Pilot operated proportional pressure reducing valve with integrated electronics as a screw-in cartridge. Thread M33x2 for cavity according to ISO 7789. These plug & play valves are factory set and adjusted. High valve-to-valve reproducibility. Housing for electronics with protection class IP67 for harsh environment. Three standard pressure levels are available: 100, 200 and 350 bar. Adjustment by a Wandfluh proportional solenoid (VDE standard 0580). The cartridge and the solenoid made of steel are zinc coated and therefore rust-protected.

FUNCTION

The proportional pressure reducing valve controls the pressure in port A (1). Proportionally to the solenoid current solenoid force and pressure in port A rise. The valve functions practically independently of the pressure in port P (2). The control connection is provided by an analog interface or a fieldbus interface (CANopen or Profibus DP). Parameter setting and diagnosis with the free-of-charge software «PASO» or via fieldbus interface. After taking off the cover of the electronics housing, the serial interface to adjust the settings is accessible. The menu controlled Windows program «PASO» allows easy adjustment of all variable settings. Data are stored in a non-volatile memory. Even after an electric power failure settings can easily be reproduced and transmitted.

APPLICATION

Proportional pressure reducing valves with integrated electronics are well suited for demanding applications, in which the pressure frequently has to be changed. They are implemented in systems calling for good valve-to-valve reproducibility, easy installation, comfortable operation and high precision in industrial hydraulics as well as in mobile hydraulics. The proportional pressure reducing cartridge is very suitable for mounting in control blocks, flange bodies and sandwich plates of the size NG10. (Please note the separate data sheets in register 2.3). Cavity tools are available for machining the cavities in steel and aluminium (hire or purchase). Please refer to the data sheets in register 2.13.

CONTENT

GENERAL SPECIFICATIONS.....	1
SYMBOL.....	1
HYDRAULIC SPECIFICATIONS.....	2
ELECTRICAL SPECIFICATIONS.....	2
START-UP.....	2
CONNECTOR WIRING DIAGRAM.....	2
CHARACTERISTICS.....	3
DIMENSIONS/ SECTIONAL DRAWINGS.....	4
PARTS LIST.....	4
ACCESSORIES (not included).....	4

TYPE CODE

	M	V	V	PM33	-		-		#	
Pressure reducing valve										
Pilot operated										
Proportional valve with integrated electronics										
Screw-in thread M33x2										
Standard nominal pressure ranges $p_{N \text{ red}}$:	100 bar									
	200 bar									
	350 bar									
Standard nominal voltage U_N :	12 VDC									
	24 VDC									
Hardware configuration:										
With analog signal (0...+10 V factory set)										A1
With CANopen acc. to DSP-408										C1
With Profibus DP in accordance with Fluid Power Technology										P1
With CAN J1939 (on request)										J1
Design-Index (Subject to change)										

• Data sheet is valid from design-index #3 on

GENERAL SPECIFICATIONS

Description	Pilot operated proportional pressure reducing valve with integrated electronics
Construction	Screw-in cartridge for cavity acc. to ISO 7789
Operations	Proportional solenoid, wet pin push type, pressure tight
Mounting	Screw-in thread M33x2
Ambient temperature	-20...+65°C (typical) <small>(The upper temperature limit is a guideline value for typical applications, in individual cases it may also be higher or lower. The electronics of the valve limit the power in case of a too high electronics temperature. More detailed information can be obtained from the operating instructions «DSV».)</small>
Mounting position	any
Fastening torque	$M_D = 80 \text{ Nm}$ for screw-in cartridge $M_D = 2,6 \text{ Nm}$ (qual. 8.8) for solenoid screws
Weight	$m = 1,35 \text{ kg}$

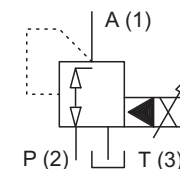
SYMBOL

HYDRAULIC SPECIFICATIONS

Fluid	Mineral oil, other fluids on request
Contamination efficiency	ISO 4406:1999, class 18/16/13 (Required filtration grade $\beta_{6...10} \geq 75$) refer to data sheet 1.0-50/2
Viscosity range	12 mm ² /s...320 mm ² /s
Fluid temperature	-20...+70°C
Peak pressure	$p_{max} = 400$ bar
Nominal pressure ranges	$p_{N red} = 100$ bar, $p_{N red} = 200$ bar, $p_{N red} = 350$ bar
Volume flow range	$Q = 0...160$ l/min
Pilot- and leakage volume flow	see characteristics
Repeatability	$\leq 1\%$
Hysteresis	$\leq 4\%$

ELECTRICAL SPECIFICATIONS

Protection class	IP 67 acc. to EN 60 529 with suitable connector and closed electronics housing
Supply voltage	12 VDC or 24 VDC
Ramps	adjustable
Parameterisation	via fieldbus or USB
Interface	USB (Mini B) for parameterisation with «PASO» (under the closing screw of the housing cover, factory set parameters)

Analog interface:

Device receptacle (male)	M23, 12-poles
Mating connector	Plug (female), M23, 12-poles (not incl. in delivery)
Preset value signal	Voltage/Current

Fieldbus interface:

Device receptacle supply (male)	M12, 4-poles
Mating connector	Plug (female), M12, 4-poles (not incl. in delivery)
Device receptacle CANopen (male)	M12, 5-poles (acc. to DRP 303-1)
Mating connector	Plug (female), M12, 5-poles (not incl. in delivery)
Device receptacle Profibus (female)	M12, 5-poles, B-coded (acc. to IEC 947-5-2)
Mating connector	Plug (male), M12, 5-poles, B-coded (not incl. in delivery)
Preset value signal	Fieldbus

NOTE!

Detailed electrical characteristics and description of «DSV» electronics are shown on data sheet **1.13-75**.

START-UP

Normally there is no need to adjust settings by the customer. The connector has to be wired according to the chapter «Connector wiring diagram».

Additional information can be found on our website:
«www.wandfluh.com»

Free-of-charge download of the «PASO»-software and the instruction manual for the «DSV» hydraulic valves as well as the operation instruction **CANopen** eg. **Profibus DP** protocol with device profile DSP-408 for «DSV».

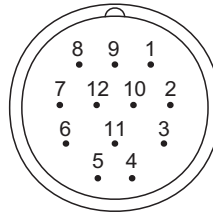
CONNECTOR WIRING DIAGRAM
Analog interface:
Device receptacle (male) X1

- 1 = Supply voltage +
- 2 = Supply voltage 0 VDC
- 3 = Stabilised output voltage
- 4 = Preset value voltage +
- 5 = Preset value voltage -
- 6 = Preset value current +
- 7 = Preset value current -
- 8 = Reserved for extensions
- 9 = Reserved for extensions
- 10 = Enable control (Digital input)
- 11 = Error signal (Digital output)
- 12 = Chassis

Preset value voltage (PIN 4/5) resp. current (PIN 6/7) are selected with set-up and diagnosis software.
Factory setting: Voltage (0...+10 V), (PIN 4/5)

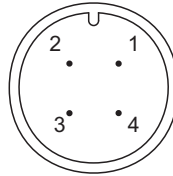
Fieldbus interface:
Device receptacle supply (male) X1

MAIN

- 1 = Supply voltage +
- 2 = Reserved for extensions
- 3 = Supply voltage 0 VDC
- 4 = Chassis

Device receptacle CANopen (male) X3

CAN

- 1 = not connected
- 2 = not connected
- 3 = CAN Gnd
- 4 = CAN High
- 5 = CAN Low

Device receptacle Profibus (female) X3

PROFIBUS

- 1 = VP
- 2 = RxD/TxD - N
- 3 = DGND
- 4 = RxD/TxD - P
- 5 = Shield

Parameterisation interface (USB, Mini B) X2

Under the closing screw of the housing cover

NOTE!

The mating connectors and the cable to adjust the settings are not part of the delivery. To order the cable, look up the article no. in the chapter «Accessories».

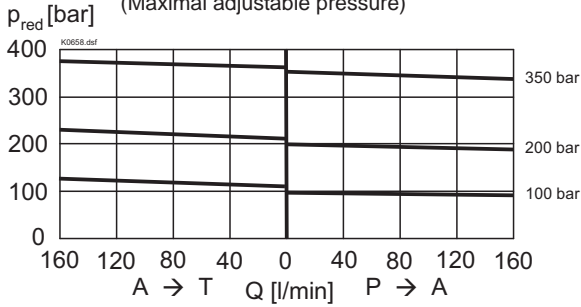
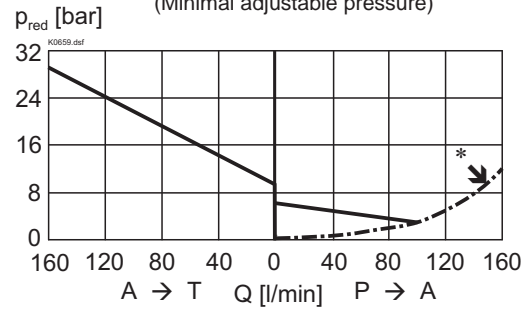
CHARACTERISTICS Oil viscosity $\nu = 30 \text{ mm}^2/\text{s}$
 $p_{\text{red}} = f(Q)$ Pressure volume flow characteristics
 (Maximal adjustable pressure)

 $p_{\text{red}} = f(Q)$ Pressure volume flow characteristics
 (Minimal adjustable pressure)

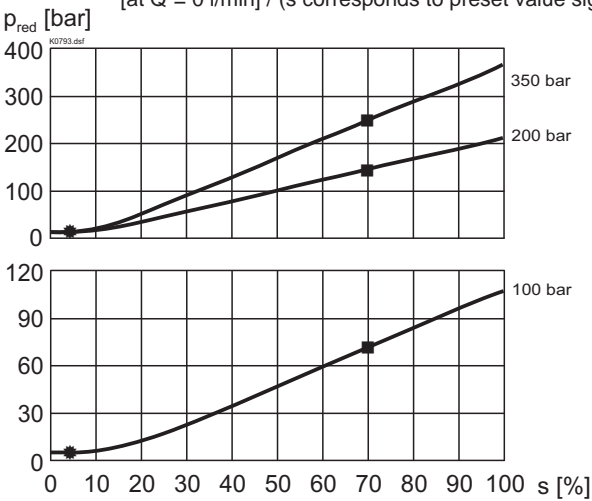
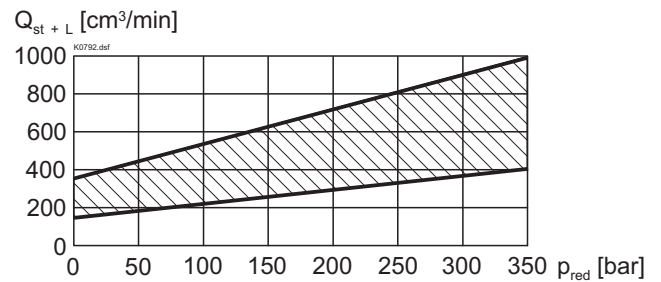
* Consumption resistance dependent on system

 $p_{\text{red}} = f(s)$ Pressure adjustment characteristics
 [at $Q = 0 \text{ l/min}$] / (s corresponds to preset value signal)

 $Q_{\text{st} + \text{L}} = f(p)$ Pilot- and leakage volume flow characteristic [A (1) \rightarrow T (3)]

 Inlet pressure: $p_N + 10\%$

Measured with closed port A (static conditions).

Factory settings:

Dither set for optimal hysteresis

- = Deadband: Solenoid switched off
with command preset value signal < 5%
- = Regulated pressure in port A (1) at 70% of preset value signal:
250 bar with pressure range 350 bar
143 bar with pressure range 200 bar
72 bar with pressure range 100 bar

DIMENSIONS/SECTIONAL DRAWINGS
With analog interface

NOTE!

The cable connector is not part of the delivery. Regarding the dimensions see also the connector in the chapter «Accessories».

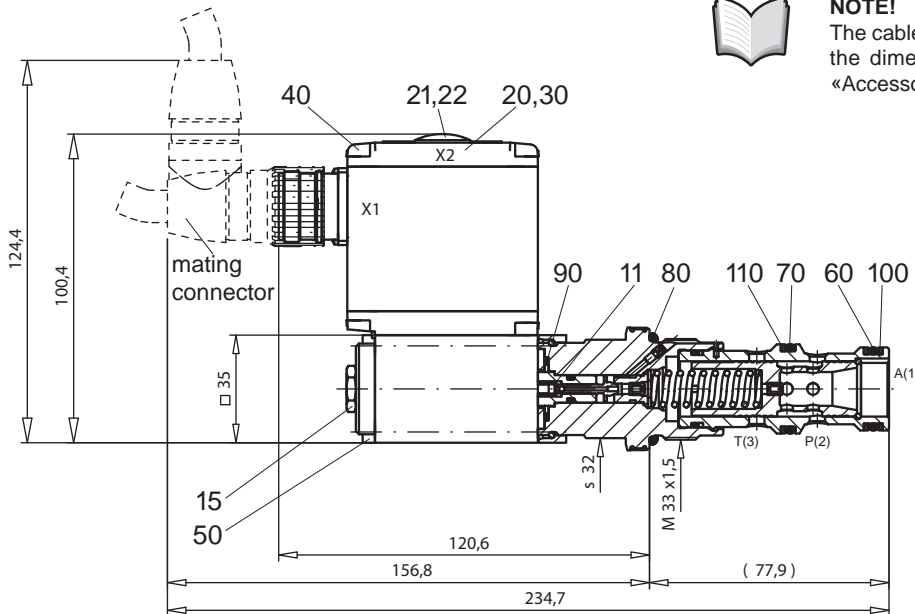
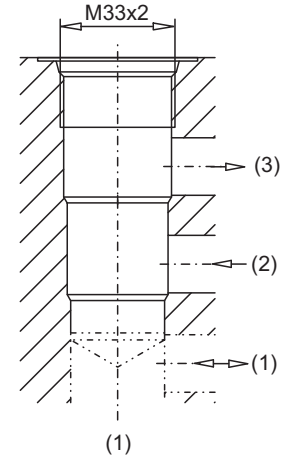
 Cavity drawing acc. to
 ISO 7789-33-04-0-98

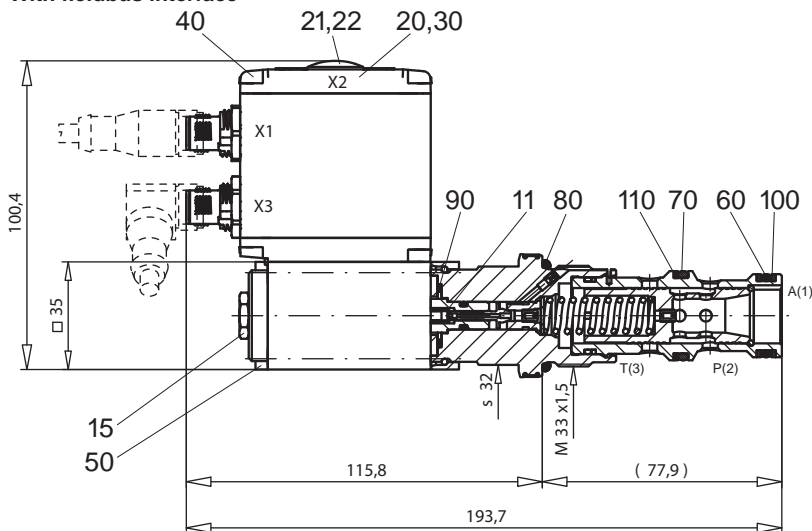
 For detailed cavity drawing
 see data sheet 2.13-1040

With fieldbus interface

PARTS LIST

Position	Article	Description
11	034.0116	Pin RD 4x8
15	253.8000	Mounted screw with integrated manual override HB4,5
20	062.0102	Cover square
21	223.1317	Dummy plug M16x1,5
22	160.6131	O-ring ID 13,00x1,5
30	072.0021	Gasket 33,2x59,9x2
40	208.0100	Socket head cap screw M4x10
50	246.1161	Socket head cap screw M4x60 DIN 912
60	160.2219	O-ring ID 21,89x2,62
70	160.2235	O-ring ID 23,47x2,62
80	160.2298	O-ring ID 29,82x2,62
90	160.2170	O-ring ID 17,17x1,78
100	049.3277	Back-up ring RD 22,5x27x1,4
110	049.3297	Back-up ring RD 24,5x29x1,4

ACCESSORIES

- Cartridge built-in:
– flange and sandwich bodies see register 2.3
- Set-up software see start-up
- Cable to adjust the settings through interface USB
(from plug type A to Mini B, 3 m) article no. 219.2896
- Cable connector for analog interface:
– straight, soldering contact article no. 219.2330
– 90°, soldering contact article no. 219.2331
Recommended cable size:
– Outer diameter 9...10,5 mm
– Single wire max. 1 mm²
– Recommended wire size:
0...25 m = 0,75 mm² (AWG18)
25...50 m = 1 mm² (AWG17)

Technical explanation see data sheet 1.0-100E