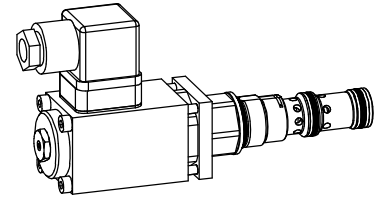

**Proportional pressure reducing valve
Screw-in cartridge**

- Pilot operated
- Statically controllable under 1 bar
- $Q_{max} = 40 \text{ l/min}$
- $p_{max} = 400 \text{ bar}$, $p_{N \text{ red max}} = 340 \text{ bar}$

M22x1,5
 ISO 7789

DESCRIPTION

Pilot operated proportional pressure reducing valve as a screw-in cartridge with a thread M22x1,5 for cavity according to ISO 7789. Six standard pressure levels are available: 30, 55, 100, 150, 240 and 340 bar. With this valve the pressure can be adjusted under 1 bar. Adjustment by a Wandfluh proportional solenoid (VDE standard 0580). The cartridge and the solenoid made of steel are zinc coated and therefore rust-protected.

FUNCTION

The proportional pressure reducing valve controls the pressure in port A (1). Proportionally to the solenoid current, the solenoid force and the pressure in port A (1) increase. The valve operates practically independently of the supply pressure in port P (2). A pressure rise in port A (1) over the set pressure, e.g. due to an active consumer, will be prevented by draining excess oil to the tank via port T (3). With the solenoid de-energised, the oil flows freely from consumer port A to tank T. For actuating the valve, proportional amplifiers are available from Wandfluh (see register 1.13).

APPLICATION

The valve is used in hydraulic systems, in which the pressure changes frequently and has to be statically controlled to below 1 bar. The capability of remote controlling the valves in conjunction with process control systems enable economical solutions with reproducible operating cycles. Installation of the screw-in cartridge in control blocks as well as in the Wandfluh sandwich plates (vertically stacked systems) and flange valves of the NG4-Mini, NG6 and NG10 types. (Please note the separate data sheets in register 2.3). Cavity tools are available for machining the cavities (hire or purchase). Please refer to the data sheets in register 2.13.

CONTENT

GENERAL SPECIFICATIONS.....	1
HYDRAULIC SPECIFICATIONS.....	1
ELECTRICAL SPECIFICATIONS.....	1
SYMBOL.....	1
CHARACTERISTICS.....	2
DIMENSIONS/ SECTIONAL DRAWINGS.....	2
PARTS LIST.....	2
ACCESSORIES.....	2

TYPE CODE

	M	Q	P	PM22	-		-		#	
Pressure reducing valve										
Pilot operated (from connection P)										
Proportional										
Screw-in thread M22x1,5										
Standard nominal pressure range $p_{N \text{ red}}$:	30 bar	<input type="text" value="30"/>	150 bar	<input type="text" value="150"/>						
	55 bar	<input type="text" value="55"/>	240 bar	<input type="text" value="240"/>						
	100 bar	<input type="text" value="100"/>	340 bar	<input type="text" value="340"/>						
Standard nominal voltage U_N :	12 VDC	<input type="text" value="G12"/>								
	24 VDC	<input type="text" value="G24"/>								
Design-Index (Subject to change)										

GENERAL SPECIFICATIONS

Denomination	Pilot operated proportional pressure reducing valve
Construction	Screw-in cartridge for cavity acc. to ISO 7789
Operation	Proportional solenoid
Mounting	Screw in thread M22x1,5
Ambient temperature	-20...50 °C
Mounting position	any
Fastening torque	$M_D = 50 \text{ Nm}$ for screw-in cartridge $M_D = 2,6 \text{ Nm}$ (Qual. 8.8) for solenoid screws
Weight	$m = 0,75 \text{ kg}$

HYDRAULIC SPECIFICATIONS

Fluid	Mineral oil, other fluid on request
Contamination efficiency	ISO 4406: 1999, class 18/16/13 Required filtration grade ($\beta_{6...10} \geq 75$) (refer to data sheet 1.0-50)
Viscosity range	12 mm ² /s...320 mm ² /s
Fluid temperature	-20...+70 °C
Peak pressure	$p_{max} = 400 \text{ bar}$ (connection P) $p_{max} = 100 \text{ bar}$ (connection T) $p_{Tmax} = p_p + 20 \text{ bar}$
Nominal pressure range	$p_{N \text{ red}} = 30, 55, 100, 150, 240, 340 \text{ bar}$
Supply pressure	$p_p \geq p_{red} + 10 \text{ bar}$ (statically) $p_p \geq p_{red} + 80 \text{ bar}$ (at 40 l/min)
Volume flow range	see characteristics
Pilot- and leakage volume flow	see characteristics
Repeatability	$\leq 3 \%$ *
Hysteresis	$\leq 5 \%$ *
	* at optimal dither signal

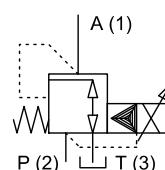

ELECTRICAL SPECIFICATIONS

Construction	Proportional solenoid, wet pin push type, pressure tight	
Standard nominal voltage	$U = 12 \text{ VDC}$	$U = 24 \text{ VDC}$
Limiting current	$I_G = 1250 \text{ mA}$	$I_G = 680 \text{ mA}$
Relative duty factor	100% ED (see date sheet 1.1-430)	
Protection class	IP 65 acc. to EN 60 529	
Connection/Power supply	Over device plug connection to EN175301-803 (DIN 43650) ISO4400, form A, (2P+E), other connections on request.	
Other electrical specifications	see data sheet 1.1-115 (PI35MV)	

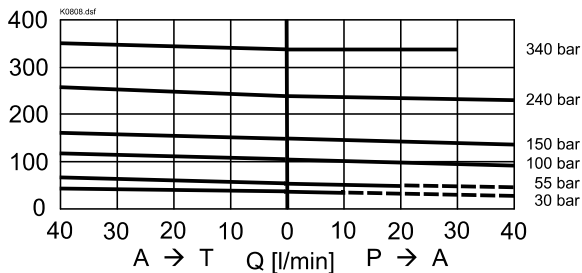
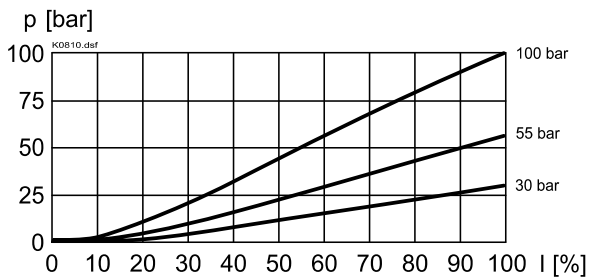
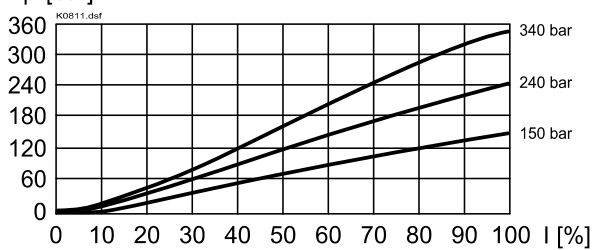
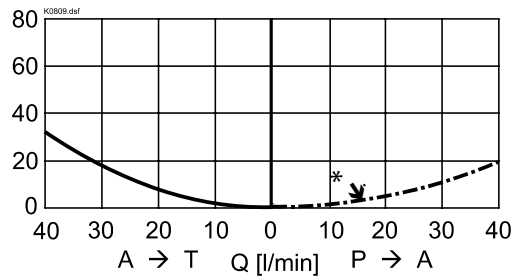
SYMBOL

CHARACTERISTICS Oil viscosity $\nu = 30 \text{ mm}^2/\text{s}$
 $p_{\text{red}} = f(Q)$ Pressure volume flow characteristics
 p [bar] (Maximal adjustable pressure)

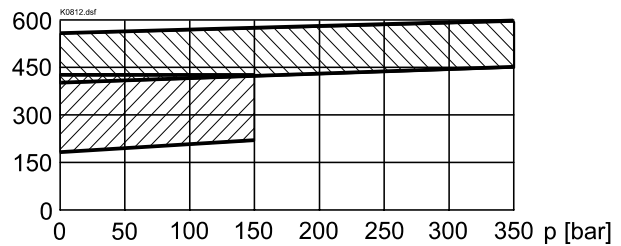
 - - - only admissible when $p_p \leq 200 \text{ bar}$
 $p_{\text{red}} = f(I)$ Pressure adjustment characteristics
 p [bar] [at $Q = 0 \text{ l/min}$ (static)]

 $p_{\text{red}} = f(Q)$ Pressure volume flow characteristics
 p [bar] (Minimal adjustable pressure)

* Consumption resistance dependent on system

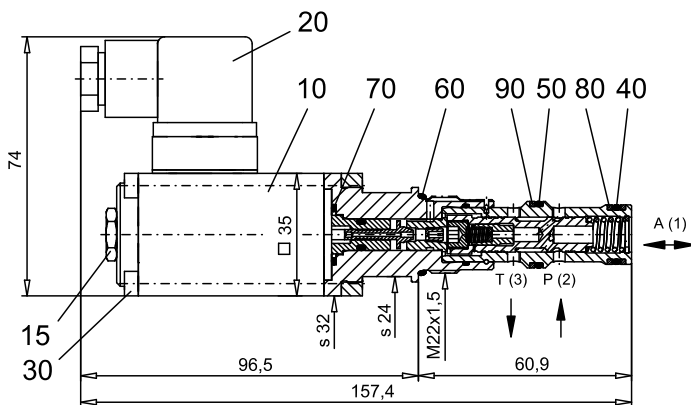
 $Q_{\text{st+L}} = f(p_{\text{red}})$ Pilot- and leakage volume flow characteristic [P (2) → T (3)]
 Q [cm³/min] (Pressure in P (2) = 350 bar)

 Pressure ranges: 240 / 340 bar

 Pressure ranges: 30 / 55 / 100 / 150 bar

DIMENSIONS / SECTIONAL DRAWINGS

For detailed cavity drawing ISO 7789-22-04-0-98 and cavity tools see data sheet 2.13-1004

PARTS LIST

Position	Article	Description
10	256.3505 256.3443	Proportional solenoid PI35MV-G24 Proportional solenoid PI35MV-G12
15	253.8000	Mounted screw with integrated manual override HB4,5
20	219.2002	Plug (black)
30	249.1007	Socket head cap screw M4x63
40	160.2140	O-ring ID 14,00x1,78
50	160.2156	O-ring ID 15,60x1,78
60	160.2188	O-ring ID 18,77x1,78
70	160.2140	O-ring ID 14,00x1,78
80	049.3176	Back-up ring RD 14,1x17x1,4
90	049.3196	Back-up ring RD 16,1x19x1,4

ACCESSORIES

 Cartridge built into flange- or sandwich body
 Flange body / sandwich plate
 Proportional amplifier

 register 2.3
 register 1.13

Technical explanation see data sheet 1.0-100E