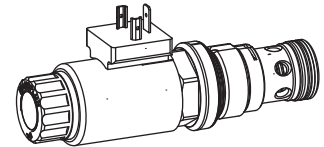

**Proportional pressure relief valve  
Screw-in cartridge**

- Pilot operated
- $Q_{max} = 230 \text{ l/min}$
- $p_{max} = 400 \text{ bar}$
- $p_{Nmax} = 350 \text{ bar}$

**M33x2**  
 ISO 7789

**DESCRIPTION**

Pilot operated, proportional pressure relief valve, as screw-in cartridge with a thread M33x2 for cavity according to ISO7789. 4 standard pressure levels are available: 100 bar, 200 bar, 275 bar and 350 bar. The adjustment takes place by means of a Wandfluh proportional solenoid (VDE-standard 0580). The cartridge body made of steel is zinc coated and therefore rust-protected. The solenoid coil is zinc-/nickel-coated.

**FUNCTION**

When the operating pressure set by the proportional solenoid is reached, the main spool opens and connects the protected line with the return line to the tank. The back pressure in T influences the pressure in P (1). This pilot operated proportional pressure relief valve can be adjusted very sensitively and is suitable for large volume flows and high pressures. To control the valve, Wandfluh proportional amplifiers are available (see register 1.13).

**APPLICATION**

The valve has its application in hydraulic systems, in which the pressure frequently has to be changed. The facility for electric remote controlling of the valve in conjunction with process control systems enables economic problem solutions with repeatable sequences. Installation of the screw-in cartridge in control blocks as well as in flange- and sandwich-valves of the NG10 type. Cavity tools are available for machining cavities in steel and aluminium (hire or purchase). Please refer to the data sheets in register 2.13.

**TYPE CODE**

		B V P PM33- [ ] - [ ] / [ ] [ ] - [ ] [ ] # [ ]	
Pressure relief valve			
Pilot operated			
Proportional			
Screw-in cartridge M33x2			
Standard nominal pressure ranges $p_N$	100 bar <input type="checkbox"/>	200 bar <input type="checkbox"/>	275 bar <input type="checkbox"/>
	200 bar <input type="checkbox"/>	275 bar <input type="checkbox"/>	350 bar <input type="checkbox"/>
Standard nominal voltage $U_N$	12 VDC <input type="checkbox"/>	24 VDC <input type="checkbox"/>	without solenoid coil <input type="checkbox"/>
Slip-on coil	Metal housing, round <input type="checkbox"/>	Metal housing, square <input type="checkbox"/>	
Electric connection	Connector socket EN 175301-803 / ISO 4400 <input type="checkbox"/>	Connector socket AMP Junior-Timer <input type="checkbox"/>	Connector Deutsch DT04-2P <input type="checkbox"/>
Sealing material	NBR <input type="checkbox"/>	FKM (Viton) <input type="checkbox"/>	
Manual override	Armature tube closed (standard) <input type="checkbox"/>	With screwed sealing plug <input type="checkbox"/>	With manual emergency actuation <input type="checkbox"/>

- Only available in conjunction with other nominal voltages and connection versions. (See data sheet 1.1-174)

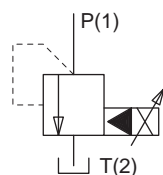
**SYMBOLS**

**GENERAL SPECIFICATIONS**

Description	Pilot operated pressure relief valve
Construction	Screw-in cartridge for cavity acc. to ISO7789
Actuation	Proportional solenoid
Mounting	Screw-in thread M33x2
Ambient temperature	-20...+70 °C
Mounting position	any, preferably horizontal
Fastening torque	$M_D = 80 \text{ Nm}$ for screw-in cartridge $M_D = 5 \text{ Nm}$ for knurled nut
Weight	$m = 0,7 \text{ kg}$

**ELECTRICAL SPECIFICATIONS**

Construction	Proportional solenoid, wet pin push type, pressure tight	
Standard nominal voltage	$U_N = 12$ VDC	$U_N = 24$ VDC
	$I_G = 1320$ mA	$I_G = 660$ mA
Limiting current		
Relative duty factor	100% ED/DF (see data sheet 1.1-430)	
Protection class acc. to EN 60529	Connection version D: IP 65 J: IP 66 G: IP 67 and 69K	

Other electrical specifications see data sheet 1.1-173 (W)  
1.1-174 (M)

**HYDRAULIC SPECIFICATIONS**

Fluid	Mineral oil, other fluid on request
Contamination efficiency	ISO 4406: 1999, class 18/16/13 (Required filtration grade $\beta_{6...10} \geq 75$ ) see data sheet 1.0-50/2
Viscosity range	12 mm <sup>2</sup> /s...320 mm <sup>2</sup> /s
Fluid temperature	-20...+70 °C
Peak pressure	$p_{max} = 400$ bar $p_{Tmax} = p_p + 15$ bar
Nominal pressure ranges	$p_N = 100$ bar, 200 bar, 275 bar, 350 bar
Volume flow	$Q = 5...230$ l/min
Leakage volume flow	see characteristics
Repeatability	$\leq 3\%$ *
Hysteresis	$\leq 4\%$ *
	* at optimal dither signal

**CHARACTERISTICS** Oil viscosity  $\nu = 30$  mm<sup>2</sup>/s

$p = f(Q)$  Pressure volume flow characteristics  
(Maximal adjustable pressure)

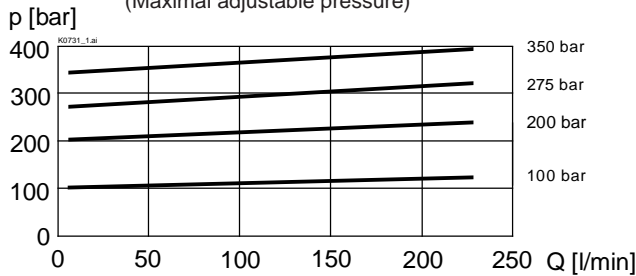

$p = f(Q)$  Pressure volume flow characteristics  
(Minimal adjustable pressure)

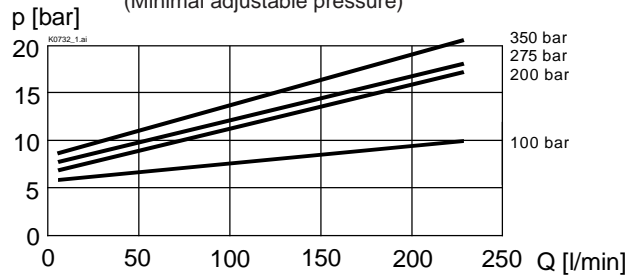

$p = f(I)$  Pressure adjustment characteristics  
[at  $Q = 30$  l/min (static)]

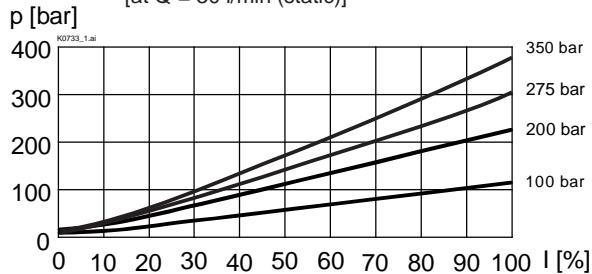

$Q_L = f(p)$  Leakage volume flow characteristics

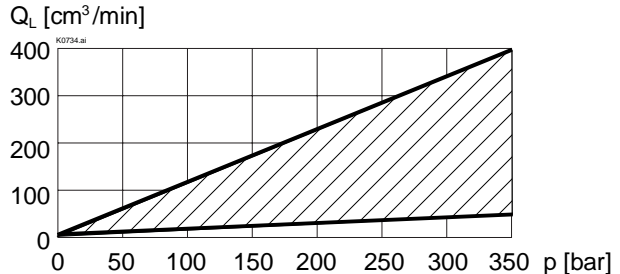

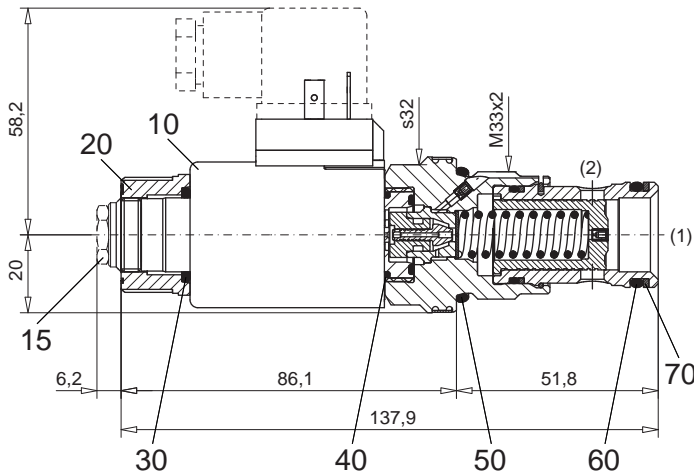
**DIMENSIONS / SECTIONAL DRAWING**

Dimensions of the other connection versions see data sheet 1.1-173

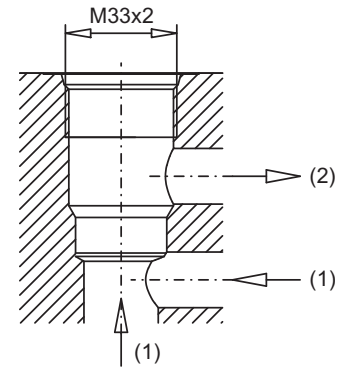
 Cavity drawing acc. to  
 ISO 7789-33-02-0-98

 For detailed cavity drawing  
 and cavity tools  
 see data sheet 2.13-1041

**PARTS LISTE**

Position	Article	Description
10	206.2201	EN 175301 Solenoid coil WD37/19x50-G24
	206.2200	Solenoid coil WD37/19x50-G12 Junior-Timer
	206.2203	Solenoid coil WJ37/19x50-G24
	206.2202	Solenoid coil WJ37/19x50-G12
	206.2205	Deutsch Solenoid coil WG37/19x50-G24
	206.2204	Solenoid coil WG37/19x50-G12
15	253.8000	HB 4,5 Manual override (data sheet 1.1-300)
	239.2033	HB 0 Plug screw (data sheet 1.1-300)
20	154.2700	Knurled nut
30	160.2187	O-ring ID 18,72x2,62 (NBR)
	160.6187	O-ring ID 18,72x2,62 (FKM)
40	160.2170	O-ring ID 17,17x1,78 (NBR)
	160.6172	O-ring ID 17,17x1,78 (FKM)
50	160.2298	O-ring ID 29,82x2,62 (NBR)
	160.6296	O-ring ID 29,82x2,62 (FKM)
60	160.2219	O-ring ID 21,89x2,62 (NBR)
	160.6216	O-ring ID 21,89x2,62 (FKM)
70	049.3277	Backup ring RD22,5x27x1,4

**ACCESSORIES**

Line mount body	Data sheet 2.9-200
Proportional amplifier	register 1.13
Mating connector EN 175301-803	Article no. 219.2002

Technical explanation see data sheet 1.0-100