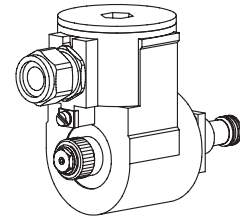

**Proportional pressure relief valve  
Screw-in cartridge**

- Direct operated
- $Q_{max} = 25 \text{ l/min}$
- $p_{max} = 350 \text{ bar}$
- $p_{Nmax} = 315 \text{ bar}$

**M22x1,5**  
 ISO 7789

**DESCRIPTION**

Direct operated proportional pressure relief valve as a screw-in cartridge with a thread M22x1,5 for cavity according to ISO 7789. Activated with explosion proof solenoid. The cartridge body made of steel is zinc coated for corrosion protection.

**Ex:** in accordance with European standards EN 60079-0, EN 60079-1

**d:** flameproof enclosure

**Group II C:** (gas group II A, II B)

for all applications except mining

**Zone 1:** (and 2) explosive mixtures present intermittently

**EC-type examination certificate:**

Execution T4: PTB 98 ATEX 1009

Execution T6: PTB 98 ATEX 1008

**FUNCTION**

The valve limits the pressure in port P (1) and relieves the volume flow to tank port T (2). The back pressure in T (2) influences the pressure in P (1). When the operating pressure set by the proportional solenoid is reached, the poppet spool opens and connects the protected line to the tank T (2). These pressure relief valves are built according to the differential spool principle and are therefore very sensitive adjustable over the whole pressure range and also suitable for systems with extremely low minimum pressures. Wandfluh proportional amplifiers are available to control the proportional pressure relief valve (register 1.13).

**APPLICATION**

The valve has its application in hydraulic systems, in which the pressure frequently has to be changed. The facility for remote control and signal processing from process control systems enable elegant, comfortable solutions to problems. Installation of the screw-in cartridge in control blocks as well as in the Wandfluh sandwich plates (vertical stacked systems) and flange valves of the NG4-Mini and NG6 types. (Please note the separate data sheets in register 2.3). Cavity tools are available for machining the cavities in steel and aluminium (hire or purchase). Please refer to the data sheets in register 2.13.

**CONTENT**

GENERAL SPECIFICATIONS .....	1
HYDRAULIC SPECIFICATIONS .....	1
SYMBOLS .....	1
ELECTRICAL SPECIFICATIONS .....	2
START-UP .....	2
CHARACTERISTICS .....	2
DIMENSIONS/ SECTIONAL DRAWING .....	2
PARTS LIST .....	2
ACCESSORIES .....	2

**TYPE CODE**

Pressure relief valve	B	D	B	PM22 -		-	G24	/		#	
Direct operated											
Proportional explosion proof, execution Ex d II C											
Screw-in cartridge M22x1,5											
Standard nominal pressure range:	$p_N = 20 \text{ bar}$				20						
	$p_N = 100 \text{ bar}$				100						
	$p_N = 200 \text{ bar}$				200						
	$p_N = 315 \text{ bar}$				315						
Standard nominal voltage:	$U_N = 24 \text{ VDC}$										
Execution:	T1...T4				T4						
	T1...T6				T6					(on request)	
Design-Index (Subject to change)											

• Data sheet is valid from design-index #2 on

**GENERAL SPECIFICATIONS**

Description	Direct operated proportional pressure relief valve
Construction	Screw-in cartridge for cavity according to ISO 7789
Operations	Proportional solenoid
Mounting	Screw-in thread M22x1,5
Admissible ambient temp. *:	
Execution T4	-20...+40 °C
Execution T6 (on request)	-20...+90 °C (operation as T1...T4) -20...+40 °C (operation as T5/T6)
Mounting position	any, preferably horizontal
Fastening torque	$M_D = 50 \text{ Nm}$ for screw-in cartridge
Weight	$m = 2,2 \text{ kg}$

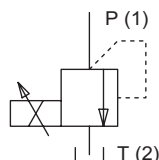
**SYMBOL**

**HYDRAULIC SPECIFICATIONS**

Fluid	Mineral oil, other fluid on request
Contamination efficiency	ISO 4406:1999, class 18/16/13 (Required filtration grade $\beta_{6...10} \geq 75$ ) see data sheet 1.0-50/2
Viscosity range	12 mm <sup>2</sup> /s...320 mm <sup>2</sup> /s
Admissible fluid temp. *:	(at inlet and at outlet)
Execution T4	-20...+40 °C
Execution T6 (on request)	-20...+70 °C (operation as T1...T4) -20...+40 °C (operation as T5/T6)
Peak pressure	$p_{max} = 350 \text{ bar}$
Nominal pressure ranges	$p_N = 20 \text{ bar}$ , $p_N = 100 \text{ bar}$ , $p_N = 200 \text{ bar}$ , $p_N = 315 \text{ bar}$
Min. volume flow	$Q_{min} = 0,1 \text{ l/min}$
Max. volume flow	$Q_{max} = 25 \text{ l/min}$ for $p_N = 20/100/200 \text{ bar}$ $Q_{max} = 20 \text{ l/min}$ for $p_N = 315 \text{ bar}$ see characteristics
Leakage volume flow	see characteristics
Repeatability	$\leq 1,5 \%$ at optimal dither signal
Hysteresis	$\leq 3 \%$ at optimal dither signal

\* Deviating pressure medium - or ambient temperatures are possible for special arrangements after checking and authorisation by a responsible inspector. Measures for the prevention of the exceeding of the admissible solenoid surface - and internal temperatures can be: a good ventilation, low ambient temperatures (for higher pressure medium temperatures), limitation of the maximum possible power supply voltage, a short switching-on duration, installation on large heat dissipating blocks, etc. The responsibility in all cases lies with the operator, resp. with his inspector.

**ELECTRICAL SPECIFICATIONS**

Construction	Proportional solenoid, wet pin push type, pressure tight
Standard nominal voltage	$U_N = 24$ VDC wired with VDR
Limiting current	T4: $I_G = 450$ mA T6: $I_G = 260$ mA (on request)
Relative duty factor	100 % ED
Protection class	IP 65 acc. to EN 60 529
Connection/Power supply	Through cable entry for cable $\varnothing 11 \dots 14$ mm (acc. to EN 60079-0)
Temperature class:	T1...T4
Execution T4	T1...T6 (on request)
Execution T6	
Performance limit:	
Execution T4	11,7 W at $I_G = 450$ mA
Execution T6	6 W at $I_G = 260$ mA (on request)

**START-UP**

Information concerning the installation and commissioning is contained in the operating instructions supplied together with the solenoid coil.

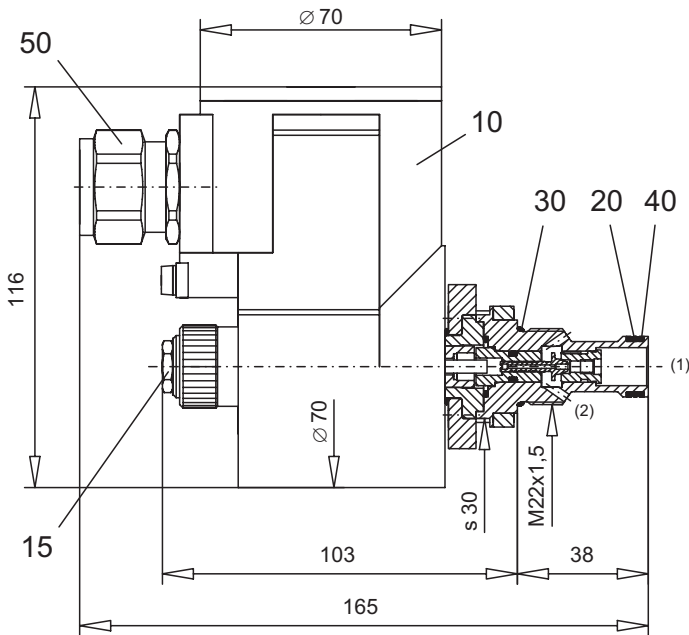
**DIMENSIONS / SECTIONAL DRAWING**

**PARTS LIST**

Position	Article	Description
10	207.5293	Slip-on coil 2A67W Exd IIC T4
15	253.8000	Plug with integrated manual override HB4,5
20	160.2140	O-ring ID 14,00x1,78
30	160.2188	O-ring ID 18,77x1,78
40	049.3177	Back-up ring RD 14,6x17,5x1,4
50	111.1080	Cable entry brass M20

**CHARACTERISTICS (T6 on request)**  
 oil viscosity  $\nu = 30$  mm<sup>2</sup>/s

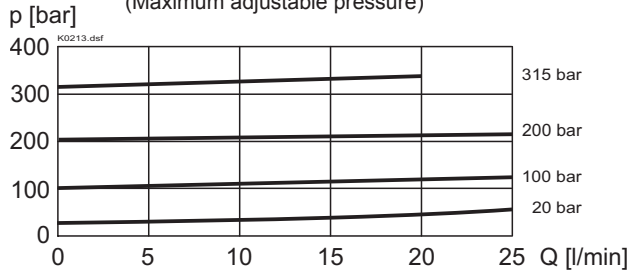
$p = f(Q)$  Pressure volume flow characteristics  
(Maximum adjustable pressure)



$p = f(Q)$  Pressure volume flow characteristics  
(Minimum adjustable pressure)

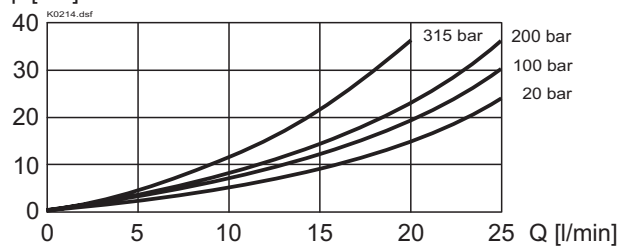

$p = f(I)$  Pressure signal characteristics  
( $Q = 1$  l/min)

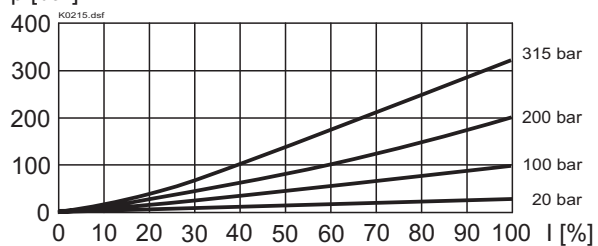

$Q_L = f(p)$  Leakage volume flow characteristics

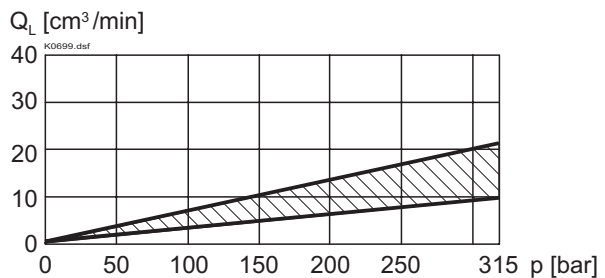
**ACCESSORIES**

Cartridge built into flange- or sandwich body	
Flange- /sandwich plate	register 2.3
Proportional amplifier	register 1.13
Cavity drawing ISO 7789-22-02-0-98 and cavity tools see	data sheet 2.13-1003

Technical explanation see data sheet 1.0-100E