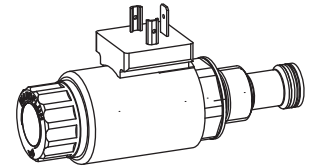

**Proportional pressure relief valve
Screw-in cartridge**

- Direct operated
- $Q_{max} = 25 \text{ l/min}$
- $p_{max} = 400 \text{ bar}$
- $p_{Nmax} = 350 \text{ bar}$

M22x1,5
 ISO 7789

DESCRIPTION

Direct operated proportional pressure relief valve as a screw-in cartridge with a thread M22x1,5 for cavity according to ISO 7789. Five standard pressure ranges are available: 20, 100, 200, 315 and 350 bar. Good flow performance thanks to the differential area principle. The guide of the tapered spool has a lower leakage rate. The adjustment takes place by means of a Wandfluh proportional solenoid (VDE-standard 0580). The cartridge body made of steel is zinc coated and therefore rust-protected. The solenoid coil is zinc-/nickel-coated.

FUNCTION

The valve limits the pressure in port P (1) and relieves the volume flow to tank port T (2). The back pressure in T influences the pressure in P (1). When the operating pressure set by the proportional solenoid is reached, the poppet spool opens and connects the protected line to the tank T (2). These pressure relief valves are built according to the differential spool principle and are therefore very sensitive adjustable over the whole pressure range and also suitable for systems with extremely low minimum pressures. Wandfluh proportional amplifiers are available to control the proportional pressure relief valve (register 1.13).

APPLICATION

The valve has its application in hydraulic systems, in which the pressure frequently has to be changed. The facility for electric remote controlling of the valve in conjunction with process control systems enables economic problem solutions with repeatable sequences. Installation of the screw-in cartridge in control blocks as well as in the Wandfluh sandwich plates (vertical stacked systems) and flange valves of the NG4-Mini and NG6 types. (Please note the separate data sheets in register 2.3). Cavity tools are available for machining the cavities in steel and aluminium (hire or purchase). Please refer to the data sheets in register 2.13.

TYPE CODE

		B D P PM22 - <input type="checkbox"/> - <input type="checkbox"/> / <input type="checkbox"/> <input type="checkbox"/> - <input type="checkbox"/> <input type="checkbox"/> # <input type="checkbox"/>									
Pressure relief valve											
Direct operated											
Proportional											
Screw-in cartridge M22x1,5											
Standard nominal pressure range p_N	20 bar <input type="checkbox"/> 20 100 bar <input type="checkbox"/> 100 200 bar <input type="checkbox"/> 200 315 bar <input type="checkbox"/> 315 350 bar <input type="checkbox"/> 350										
Standard nominal voltage U_N	12 VDC <input type="checkbox"/> G12 24 VDC <input type="checkbox"/> G24 without solenoid coil <input type="checkbox"/> X5										
Slip-on coil	Metal housing, round <input type="checkbox"/> W Metal housing, square <input type="checkbox"/> M*										
Electric connection	Connector socket EN 175301-803 / ISO 4400 <input type="checkbox"/> D Connector socket AMP Junior-Timer <input type="checkbox"/> J Connector Deutsch DT04-2P <input type="checkbox"/> G										
Sealing material	NBR <input type="checkbox"/> FKM (Viton) <input type="checkbox"/> D1										
Manual override	Armature tube closed (standard) <input type="checkbox"/> With screwed sealing plug <input type="checkbox"/> HB0 With manual emergency actuation <input type="checkbox"/> HB4.5										
Design-Index (Subject to change)											

- Only available in conjunction with other nominal voltages and connection versions. (See data sheet 1.1-174)

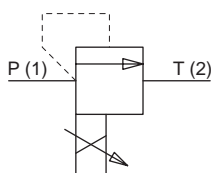
SYMBOLS

GENERAL SPECIFICATIONS

Description	Direct operated proportional pressure relief valve
Construction	Screw-in cartridge for cavity to ISO 7789
Actuation	Proportional solenoid
Mounting	Screw-in thread M22 x 1,5
Ambient temperature	-20...+70 °C
Mounting position	any
Fastening torque	$M_D = 50 \text{ Nm}$ for screw-in cartridge $M_D = 5 \text{ Nm}$ for knurled nut
Weight	$m = 0,6 \text{ kg}$

ELECTRICAL SPECIFICATIONS

Construction	Proportional solenoid, wet pin push type, pressure tight	
Standard nominal voltage	$U_N = 12$ VDC	$U_N = 24$ VDC
	$I_G = 1320$ mA	$I_G = 660$ mA
Limiting current		
Relative duty factor	100% ED/DF (see data sheet 1.1-430)	
Protection class acc. to EN 60529	Connection version D: IP 65 J: IP 66 G: IP 67 and 69K	

For further electrical specifications see data sheet 1.1-173 (W)
 1.1-174 (M)

HYDRAULIC SPECIFICATIONS

Fluid	Mineral oil, other fluid on request
Contamination efficiency	ISO 4406:1999, class 18/16/13 (Required filtration grade $\beta_{6...10} \geq 75$) see data sheet 1.0-50/2
Viscosity range	12 mm ² /s...320 mm ² /s
Fluid temperature	-20...+70 °C
Peak pressure	$p_{max} = 400$ bar
Nominal pressure ranges	$p_N = 20$ bar, 100 bar, 200 bar, 315 bar, 350 bar
Min. volume flow	$Q_{min} = 0,1$ l/min
Max. volume flow	$Q_{max} = 25$ l/min for $p_N = 20/100/200$ bar
	$Q_{max} = 20$ l/min for $p_N = 315$ bar
	$Q_{max} = 2$ l/min for $p_N = 350$ bar
Leakage volume flow	see characteristics
Repeatability	$\leq 1,5\%$ *
Hysteresis	$\leq 3\%$ *
	* at optimal dither signal

CHARACTERISTICS Oil viscosity $\nu = 30$ mm²/s

$p = f(Q)$ Pressure volume flow characteristics
 (Maximum adjustable pressure)

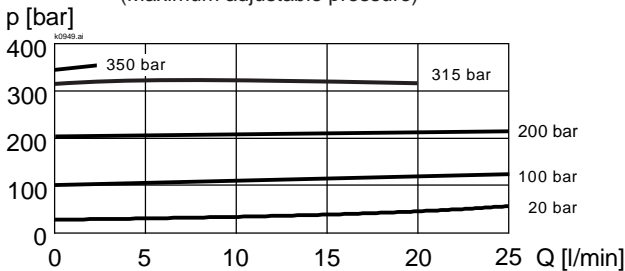

$p = f(Q)$ Pressure volume flow characteristics
 (Minimum adjustable pressure)

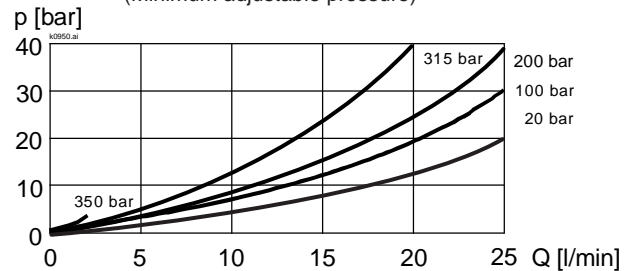

$p = f(I)$ Pressure adjustment characteristics
 ($Q = 1$ l/min)

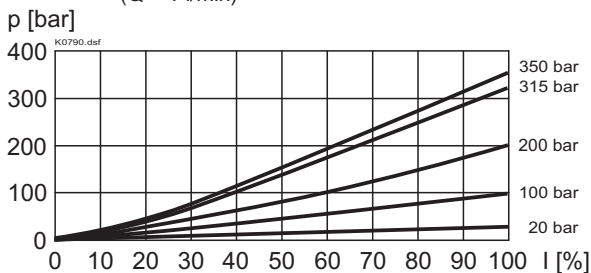

$Q_L = f(p)$ Leakage volume flow characteristics

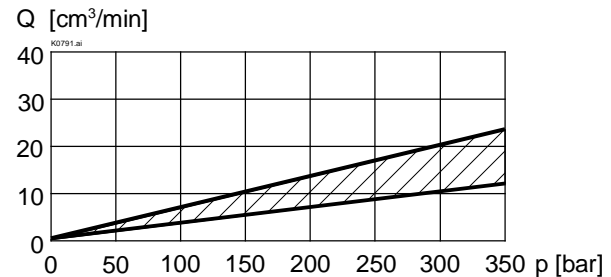

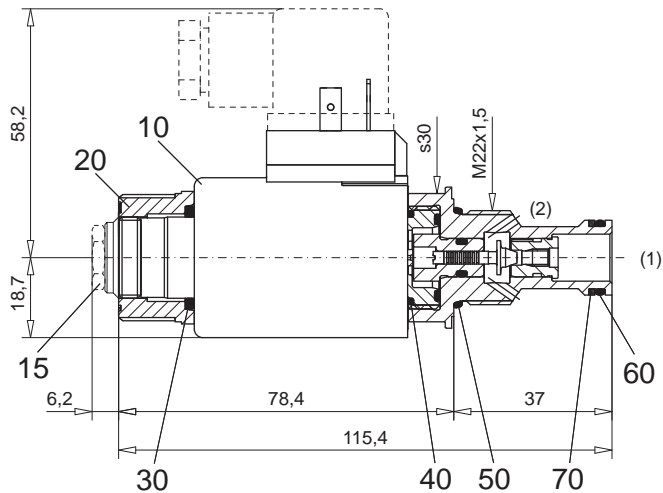
DIMENSIONS / SECTIONAL DRAWINGS

Dimensions of the other connection versions see data sheet 1.1-173

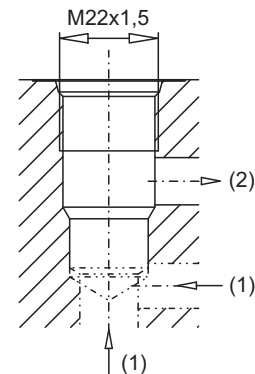
 Cavity drawing acc. to
 ISO 7789-22-02-0-98

 For detailed cavity drawing
 and cavity tools
 see data sheet 2.13-1003

PARTS LIST

Position	Article	Description
10	206.2201	EN 175301 Solenoid coil WD37/19x50-G24
	206.2200	Solenoid coil WD37/19x50-G12
		Junior-Timer
	206.2203	Solenoid coil WJ37/19x50-G24
	206.2202	Solenoid coil WJ37/19x50-G12
		Deutsch
15	206.2205	Solenoid coil WG37/19x50-G24
	206.2204	Solenoid coil WG37/19x50-G12
15	253.8000	HB 4,5 Manual override (data sheet 1.1-300)
	239.2033	HB 0 Plug screw (data sheet 1.1-300)
20	154.2700	Knurled nut
30	160.2187	O-ring ID 18,72x2,62 (NBR)
	160.6187	O-ring ID 18,72x2,62 (FKM)
40	160.2170	O-ring ID 17,17x1,78 (NBR)
	160.6172	O-ring ID 17,17x1,78 (FKM)
50	160.2188	O-ring ID 18,77x1,78 (NBR)
	160.6188	O-ring ID 18,77x1,78 (FKM)
60	160.2140	O-ring ID 14,00x1,78 (NBR)
	160.6141	O-ring ID 14,00x1,78 (FKM)
70	049.3177	Backup ring RD14,6x17,5x1,4

ACCESSORIES

Flange-/sandwich plate	Register 2.3
Line mount body	Data sheet 2.9-200
Proportional amplifier	Register 1.13
Mating connector EN 175301-803	Article Nr. 219.2002

Technical explanation see data sheet 1.0-100