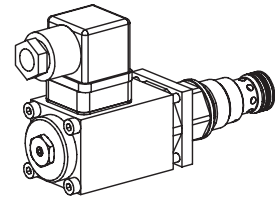

**Proportional pressure relief valve
 Screw-in cartridge**

- Pilot operated
- $Q_{max} = 100 \text{ l/min}$
- $p_{max} = 400 \text{ bar}$
- $p_{Nmax} = 350 \text{ bar}$

M22x1,5
 ISO 7789

DESCRIPTION

Pilot operated proportional pressure relief valve as a screw-in cartridge with a thread M22x1,5 for cavity according to ISO 7789. 7 standard pressure levels are available. Adjustment by a Wandfluh proportional solenoid (VDE standard 0580). The cartridge and the solenoid made of steel are zinc coated and therefore rust-protected.

FUNCTION

When the operating pressure set by the proportional solenoid is reached, the main spool opens and connects the protected line with the return line to the tank. The back pressure in T (2) influences the pressure in P (1). This pilot operated proportional pressure relief valve can be adjusted very sensitively and is suitable for large volume flows and high pressures. To control the valve Wandfluh proportional amplifiers are available (see register 1.13).

APPLICATION

The valve has its application in hydraulic systems, in which the pressure frequently has to be changed. The facility for remote control and signal processing from process control systems enable elegant, comfortable solutions to problems. Installation of the screw-in cartridge in control blocks as well as in the Wandfluh sandwich plates (vertical stacked systems) and flange valves of the NG4-Mini, NG6 and NG10 types. (Please note the separate data sheets in register 2.3). Cavity tools are available for machining the cavities in steel and aluminium (hire or purchase). Please refer to the data sheets in register 2.13.

CONTENT

GENERAL SPECIFICATIONS	1
HYDRAULIC SPECIFICATIONS	1
ELECTRICAL SPECIFICATIONS	1
SYMBOL	1
CHARACTERISTICS	2
DIMENSIONS/ SECTIONAL DRAWINGS	2
PARTS LIST	2
ACCESSORIES	2

TYPE CODE

	B	V	P	PM22	-		-		#			
Pressure relief valve												
Pilot operated												
Proportional												
Screw-in cartridge M22x1,5												
Standard nominal pressure range:	$p_N = 20 \text{ bar}$	<input type="text" value="20"/>	$p_N = 200 \text{ bar}$	<input type="text" value="200"/>	$p_N = 63 \text{ bar}$	<input type="text" value="63"/>	$p_N = 250 \text{ bar}$	<input type="text" value="250"/>	$p_N = 100 \text{ bar}$	<input type="text" value="100"/>	$p_N = 350 \text{ bar}$	<input type="text" value="350"/>
	$p_N = 160 \text{ bar}$	<input type="text" value="160"/>										
Standard nominal voltage:	$U_N = 12 \text{ VDC}$	<input type="text" value="G12"/>	$U_N = 24 \text{ VDC}$	<input type="text" value="G24"/>								

Design-Index (Subject to change)

• Data sheet is valid from design-index #2 on

GENERAL SPECIFICATIONS

Description	Pilot operated proportional pressure relief valve
Construction	Screw-in cartridge for cavity to ISO 7789
Operations	Proportional solenoid
Mounting	Screw-in thread M22x1,5
Ambient temperature	-20...50 °C
Mounting position	any
Fastening torque	$M_D = 50 \text{ Nm}$ for screw-in cartridge $M_D = 2,6 \text{ Nm}$ (qual. 8.8) for solenoid screws
Weight	$m = 0,6 \text{ kg}$

HYDRAULIC SPECIFICATIONS

Fluid	Mineral oil, other fluid on request
Contamination efficiency	ISO 4406:1999, class 18/16/13 (Required filtration grade $\beta_{6...10} \geq 75$) see data sheet 1.0-50/2
Viscosity range	12 mm ² /s...320 mm ² /s
Fluid temperature	-20...+70 °C
Peak pressure	$p_{max} = 400 \text{ bar}$ $p_{Tmax} = p_p + 20 \text{ bar}$
Nominal pressure ranges	$p_N = 20 \text{ bar}, p_N = 63 \text{ bar}$ $p_N = 100 \text{ bar}, p_N = 160 \text{ bar}$ $p_N = 200 \text{ bar}, p_N = 250 \text{ bar}$ $p_N = 350 \text{ bar}$
Volume flow	$Q = 0,3...100 \text{ l/min}$
Leakage volume flow	see characteristics
Repeatability	≤ 3 % *
Hysteresis	≤ 4 % *
	* at optimal dither signal

ELECTRICAL SPECIFICATIONS

Construction	Proportional solenoid, wet pin push type, pressure tight.	
Standard-Nominal voltage	$U_N = 12 \text{ VDC}$	$U_N = 24 \text{ VDC}$
Limiting current	$I_G = 1250 \text{ mA}$	$I_G = 680 \text{ mA}$
Relative duty factor	100% DF (see data sheet 1.1-430)	
Protection class	IP 65 acc. to EN 60 529	
Connection/Power supply	Over device plug connection to ISO 4400/DIN 43 650 (2P+E)	
Other electrical specifications	see data sheet 1.1-115 (PI35V)	

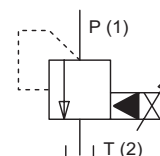
SYMBOL

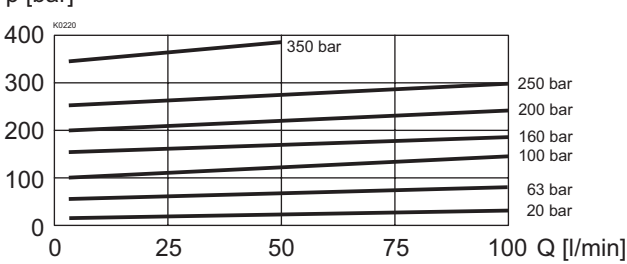
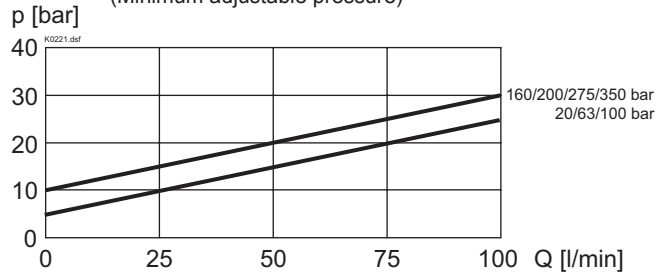
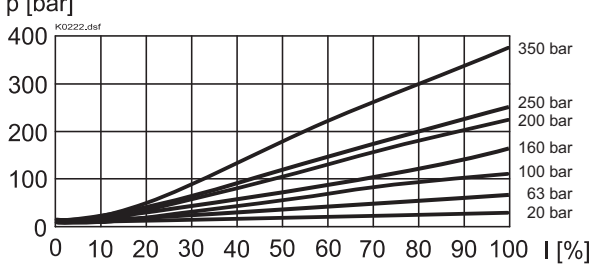
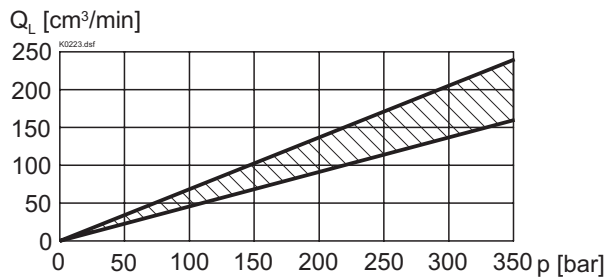
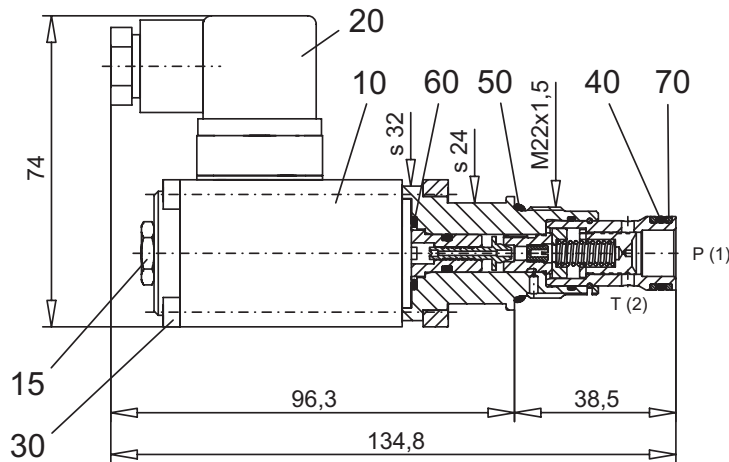
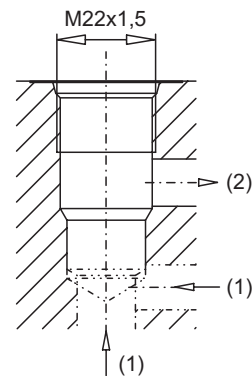
CHARACTERISTICS oil viscosity $\nu = 30 \text{ mm}^2/\text{s}$
 $p = f(Q)$ Pressure volume flow characteristics
 (Maximum adjustable pressure)

 $p = f(Q)$ Pressure volume flow characteristics
 (Minimum adjustable pressure)

 $p = f(I)$ Pressure adjustment characteristics
 ($Q = 10 \text{ l/min}$)

 $Q_L = f(p)$ Leakage volume flow characteristics

DIMENSIONS / SECTIONAL DRAWINGS

 Cavity drawing according to
 ISO 7789-22-02-0-98

 For detailed cavity drawing
 and cavity tools see data
 sheet 2.13-1003

PARTS LIST

Position	Article	Description
10	256.3505 256.3443	Proportional solenoid PI35MV-G24 Proportional solenoid PI35MV-G12
15	253.8000	Mounted screw with integrated manual override HB4,5
20	219.2002	Plug (black)
30	249.1007	Socket head cap screw M4x63
40	160.2140	O-ring ID 14,00x1,78
50	160.2188	O-ring ID 18,77x1,78
60	160.2140	O-ring ID 14,00x1,78
70	049.3177	Back up ring RD 14,6x17,5x1,4

ACCESSORIES

 Cartridge built-in flange- or sandwich body
 Flange body/sandwich plate
 Proportional amplifier

 Register 2.3
 Register 1.13

Technical explanation see data sheet 1.0-100E