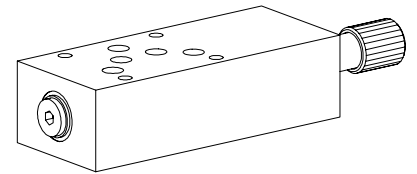

**Accumulator unloading valve  
Sandwich construction**

- 1-point adjustment
- Pilot operated
- $Q_{max} = 30 \text{ l/min}$
- $p_{max} = 400 \text{ bar}$
- $p_{Nmax} = 350 \text{ bar}$

**NG10**  
ISO 4401-05

**DESCRIPTION**

Sandwich type pilot operated accumulator unloading valve. Mounting interface acc. to ISO 4401-05. The valve is available with two types of setting, both interlockable. There are three pressure stages to choose from. The valve has an adjustable unloading point and a defined re-switching difference. The steel bodies of the sandwich valve are phosphate coated. Steel cartridge body and adjustment spindle galvanised to protect them against corrosion. The aluminium knob has a natural anodised finish. The quality of this product is reflected in the good performance data and design.

**FUNCTION**

If the P pressure exceeds the adjustable unloading point, the pilot spool is opening the pilot valve. A control flow starts to flow and the back end of the main spool is depressurised. The resultant pressure difference displaces the main spool towards the spring and the valve switches to unloading circulation. Because of the difference in section in the pilot aerea, the pilot flow is interrupted as soon as the pressure in the accumulator drops by 15 % or 25 % of the upper switching point. The pressures at the main spool are equilibrated and the spring displaces the main spool to the closed position. The pump can now build up the system pressure again as far as the unloading point and the cycle starts again.

**APPLICATION**

Accumulator loading valves are used in hydraulic systems with accumulators. They allow a low cost, energy saving system design in cases where the cylinder flow demand varies considerably or for retaining pressures over a period of time, e.g. for clamping processes. **Note:** An additional relief valve for system protection must be installed. Please refer to the set-up and connection exemple on page 2.

**CONTENT**

GENERAL SPECIFICATIONS .....	1
HYDRAULIC SPECIFICATIONS .....	1
SYMBOL .....	2
CHARACTERISTICS .....	2
DIMENSIONS .....	2
PARTS LIST .....	2
SET-UP- CONNECTION EXEMPLES .....	2

**TYPE CODE**

	US <input type="checkbox"/> S <input type="checkbox"/> A10 - P <input type="checkbox"/> # <input type="checkbox"/>						
Accumulator unloading valve							
Settings versions: screw knob	<table border="1" style="margin-left: auto; margin-right: auto;"> <tr> <td style="text-align: center;">S</td> </tr> <tr> <td style="text-align: center;">D</td> </tr> </table>	S	D				
S							
D							
Sandwich construction							
International standard interface ISO, NG10							
Accumulator loading in P							
Standard nominal pressure ranges:	<table border="1" style="margin-left: auto; margin-right: auto;"> <tr> <td><math>p_N = 100 \text{ bar}</math></td> <td style="text-align: center;">100</td> </tr> <tr> <td><math>p_N = 160 \text{ bar}</math></td> <td style="text-align: center;">160</td> </tr> <tr> <td><math>p_N = 350 \text{ bar}</math></td> <td style="text-align: center;">350</td> </tr> </table>	$p_N = 100 \text{ bar}$	100	$p_N = 160 \text{ bar}$	160	$p_N = 350 \text{ bar}$	350
$p_N = 100 \text{ bar}$	100						
$p_N = 160 \text{ bar}$	160						
$p_N = 350 \text{ bar}$	350						
Design-Index (Subject to change)							

**GENERAL SPECIFICATIONS**

Description	Pilot operated accumulator unloading valve
Norminal size	NG10 according to ISO 4401-05
Construction	Sandwich construction
Mounting	4 holes for socket cap screw M6 or studs M6
Connections	Connection plates Multi-station flange subplate Longitudinal stacking system
Mounting position	any
Ambient temperature	-20...+50°C
Fastening torque	$M_D = 9,5 \text{ Nm}$ (Qual 8.8) for fixing screw $M_D = 50 \text{ Nm}$ for screw cartridge
Weight	$m = 2,7 \text{ kg}$

**HYDRAULIC SPECIFICATIONS**

Fluid	Mineral oil, other fluid on request
Contamination efficiency	ISO 4406:1999, class 18/16/13 (Required filtration grade $\beta_{6...10} \geq 75$ ) refer to data sheet 1.0-50/2
Viscosity range	12 mm <sup>2</sup> /s...320 mm <sup>2</sup> /s
Fluid temperature	-20...+70°C
Peak pressure	$p_{max} = 400 \text{ bar}$
Norminal pressure	$p_N = 100 \text{ bar}$ , $p_N = 160 \text{ bar}$ , $p_N = 350 \text{ bar}$
Minimum pressure	$p_{min} = 50 \text{ bar}$ for $p_N 160 / 350 \text{ bar}$ $p_{min} = 25 \text{ bar}$ for $p_N 100 \text{ bar}$ $15 \pm 3 \%$ for $p_N = 160 / 350 \text{ bar}$ $25 \pm 3 \%$ for $p_N = 100 \text{ bar}$
Diff. unloading/loading	$Q_{min} = 1...30 \text{ l/min}$ (over 30 l/min on request)
Volume flow	Maximum 4 drops/min in accumulator operation P - T
Leakage volume flow	

For further hydraulic characteristics refer to data sheet: 2.1-548

**SYMBOL**

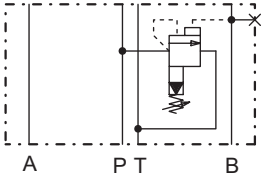

**CHARACTERISTICS** oilviscosity  $\nu = 30\text{mm}^2/\text{s}$

$\Delta p = f(Q)$  Pressure drop-volume flow curve  
(Accumulator operation - pump unloading P-T)

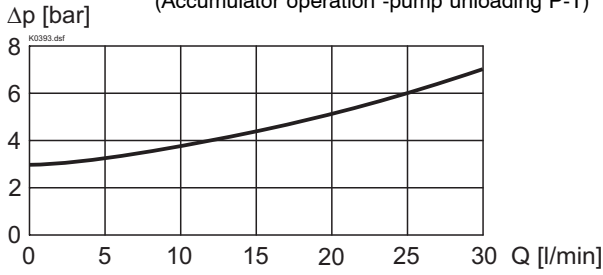

$p = f(n)$  Turns pressure adjustment characteristics  
(at  $Q = 2 \text{ l/min}$ )

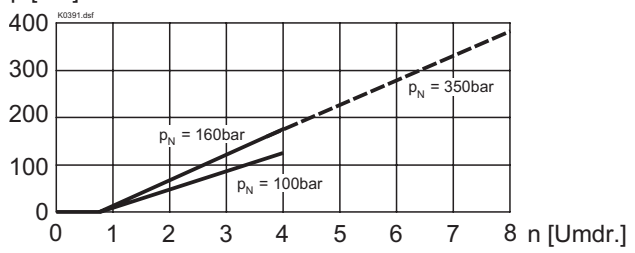

**DIMENSIONS**

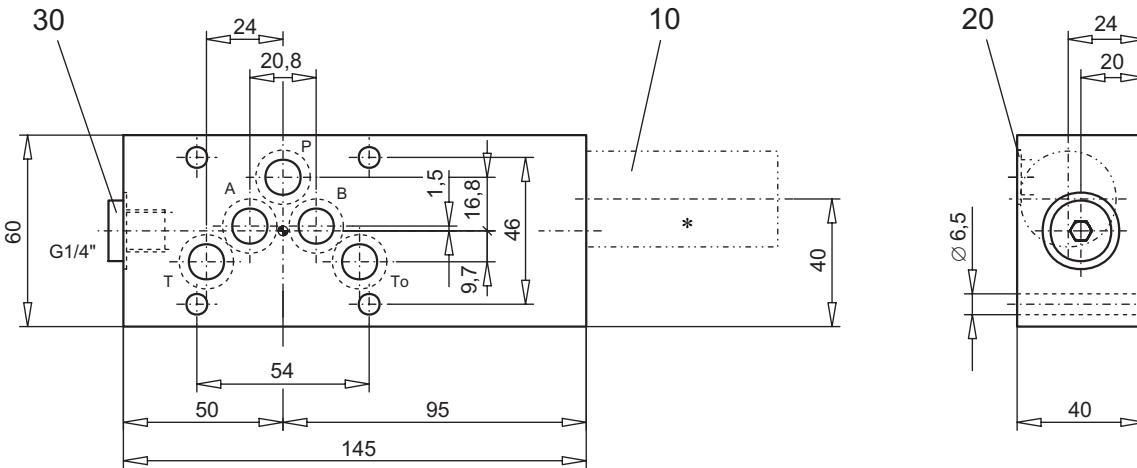

\* The exterior dimensions of the cartridge can be obtained from the corresponding data sheet 2.1-548

**PARTS LIST**

Position	Article	Description
10	597. ....	Accumulator loading cartridge M22x1,5 acc. to data sheet 2.1-548
20	160.2140	O-ring ID 14,00x1,78
30	238.2406	Plug VSTI G1/4"-ED

**SET-UP AND CONNECTION EXAMPLES**

Unloading point adjusted at 100 bar (OS)  
Differential value 15%  
Loading point: (US) = OS minus 15% = 85 bar  
Gas side of accumulator loaded upto max. 90% of US = 76 bar

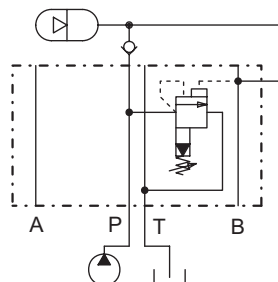

Technical explanation see data sheet 1.0-100E