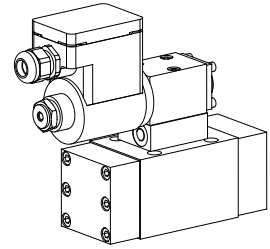

Spool valve pilot operated

- 4/2-way impuls version detented
- 4/3-way with spring centred mid position
- 4/2-way with spring reset
- $Q_{\max} = 100 \text{ l/min}$, $p_{\max} = 315 \text{ bar}$

NG10
 ISO 4401-05

II 2 G / II 2 D
EEx em II

DESCRIPTION

Pilot operated spool valve in flange type NG10 with 4 connections. Pilot valve as direct operated spool valve with a 5 annular chamber body design. Spool made from hardened steel. Valve body made from high grade hydraulic cast iron.

EEx: in accordance with european standards EN 50014, EN 50019, EN 50028

e: increased safety

m: encapsulation

Group II:

for all applications except mining

Zone 1 / 21 (and 2 / 22):

explosive mixtures present intermittently

EC-type examination certificate:

PTB 01 ATEX 2129 X

FUNCTION

By operating the pilot valve pressure will be applied to one end of the main spool and move it into activated position as indicated on table.

- 4/2-way impuls valve
- 4/3-way spring centered
- 4/2-way spring reset

(see data sheets of the corresponding pilot valves) Pilot pressure supply and drain either internal are as an option external through a ported sandwich plate between main and pilot valve.

APPLICATION

Solenoid operated spool valves are mainly used to control the direction of movement and retain hydraulic cylinders and motors. The direction of flow through the valve is determined by the spool symbol. Pilot operated valves are used where high flows have to be controlled. These valves are suitable for hazardous areas in off-shore and shipbuilding applications as well as in chemical, oil and gas industry.

TYPE CODE

	A	EX	VP	4		-		-	S1788	-		/		#	
International interface ISO															
Pilot operated valve:															
Explosion proof solenoid															
Pilot operated spool valve															
No. of control ports															
Type charts/Symbols acc. to table 1.9-35/2															
Pilot pressure supply and drain:															
Pressure supply (x) and drain (y) internal															
Pressure supply (x) and drain (y) external															
Pressure supply (x) internal drain (y) external															
Pressure supply (x) external drain (y) internal															
Terminal box without cable															
Standard nominal voltage U_N :	24 VDC														
		G24			115 VAC										
					230 VAC										
Execution:	T1...T4														
	T1...T6														
Design-Index (Subject to change)															

GENERAL SPECIFICATIONS

Description	4/2-, 4/3-way valve	Mountin position	any, preferably horizontal
Nominal size	NG10 to ISO 4401-05	Fastening torque	$M_0 = 9,5 \text{ Nm}$ (screw quality 8.8)
Construction	Pilot operated spool valve	Weight: Main valve	$m = 3,6 \text{ kg}$
Operations	Solenoid operated valve	Sandwich plate	$m = 0,4 \text{ kg}$
Pilot supply valves	BEX4.4. Data sheet 1.3-21	Pilot valve	$m = 1,8 \dots 2,6 \text{ kg}$ depending on the valve typ
Mounting	Flange mounting 4 holes for socket cap screws M6 x65		
Connections	Threaded connection plates Multi-flange plates Longitudinal stacking system		
Admissible ambient temp. *:			
Execution T4	-20...+40°C		
Execution T6	-20...+70°C (operation as T1...T4) -20...+40°C (operation as T5/T6)		

HYDRAULIC SPECIFICATIONS

Fluid	Mineral oil, other fluid on request
Contamination efficiency	ISO 4406:1999, class 20/18/14 (Required filtration grade $\beta_{10} \dots 16 \geq 75$) refer to data sheet 1.0-50/2
Viscosity range	12 mm ² /s...320 mm ² /s
Admissible fluid temp. *:	
Execution T4	-20...+40°C
Execution T6	-20...+70°C (operation as T1...T4) -20...+40°C (operation as T5/T6)
Operating pressure in port P, A, B	$p_{max} = 315 \text{ bar}$
Tank pressure in port T	$p_{Tmax} = 160 \text{ bar}$ at pilot supply te and pi $p_{Tmax} = 100 \text{ bar}$ at pilot supply ti and pe p_T minimum 12 bar deeper at p_v
Pilot over sandwich plate	$p_{vmin} = 12 \text{ bar}$ $p_{vmax} = 315 \text{ bar}$
Max. volume flow	$Q_{max} = 100 \text{ l/min}$
Leakage volume flow	see characteristics

* Deviating pressure medium - or ambient temperatures are possible for special arrangements after checking and authorisation by a responsible inspector. Measures for the prevention of the exceeding of the admissible solenoid surface - and internal temperatures can be: a good ventilation, low ambient temperatures (for higher pressure medium temperatures), limitation of the maximum possible power supply voltage, a short switching-on duration, installation on large heat dissipating blocks, etc. The responsibility in all cases lies with the operator, resp. with his inspector.

ELECTRICAL CONTROL

Construction	Solenoid, wet pin push type, pressure tight
Standard-nominal voltage	$U_N = 24 \text{ VDC}$ $U_N = 115 \text{ VAC}$, $U_N = 230 \text{ VAC}$ DC = Ripple at to 20%; wired with VDR AC = 50 bis 60 Hz $\pm 2\%$; with half wave rectifier and recovery diode
Voltage tolerance	$\pm 10\%$ of nominal voltage
Protection class	IP65 / IP67 acc. to EN 60 529
Relative duty factor	100% DF
Switching cycles	12 000/h
Operating life	10^7 (number of switching cycles, theoretically)
Connection/Power supply	Through cable entry for cable diameter 6...12 mm
Designation	
Execution T4:	II 2 G EEx em II T4 (for gas) II 2 D IP65 T130°C (for dust)
Execution T6:	II 2 G EEx em II T6 (for gas) II 2 D IP65 T80°C (for dust)
Nominal power	
Execution T4:	17 W (DC), 23 VA (AC)
Execution T6:	7 W (DC), 11 VA (AC)

START-UP

1. In the power supply for each solenoid a fuse of an appropriate rating (max. 3 times I_B of solenoid, DIN 41571 or IEC 127) respectively a motor circuit breaker with electromagnetic an thermal interruption must be installed. The fuse may be located in the power supply unit for the solenoid or between power supply and solenoid. The voltage rating for the fuse must be equal or higher than the one for the solenoid.

2. The solenoid coils must only be operated on the valve belonging to them. More information concerning the installation and commissioning is contained in the operating instructions supplied together with the solenoid coil.

TYPE LIST / DESIGNATION OF SYMBOLS

4/2-way valve with 2 solenoids

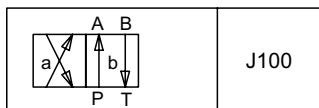

4/2-way valve with spring reset operation A-side

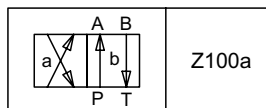

operation B-side

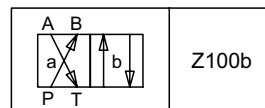

Transitional functions

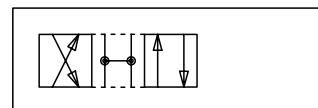

4/3-way valve spring centered

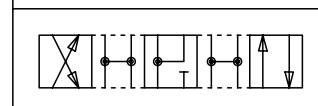
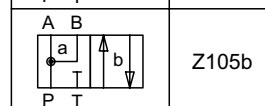
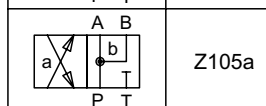
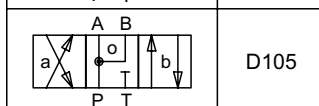
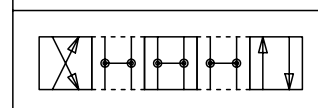
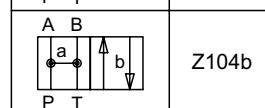
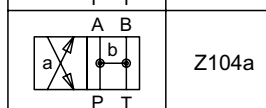
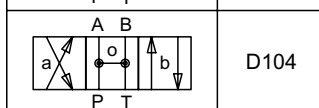
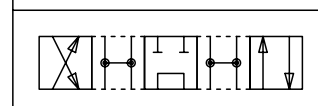
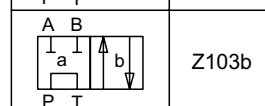
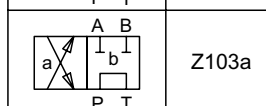
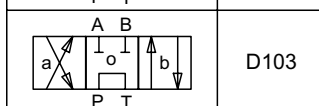
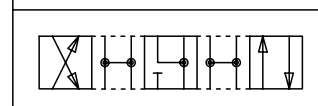
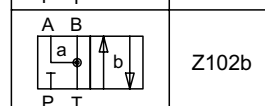
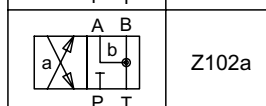
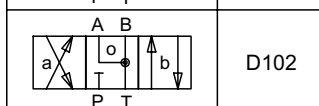
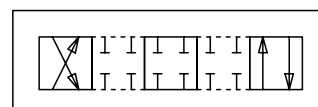
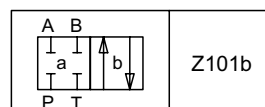
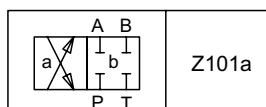
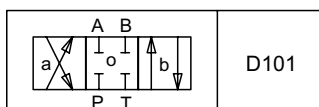

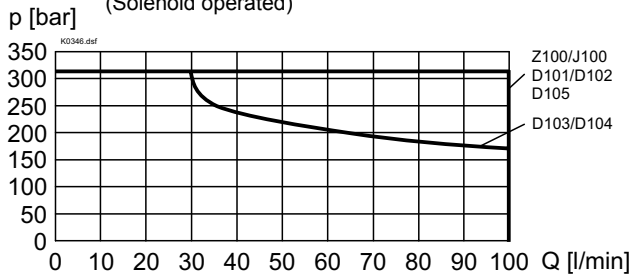
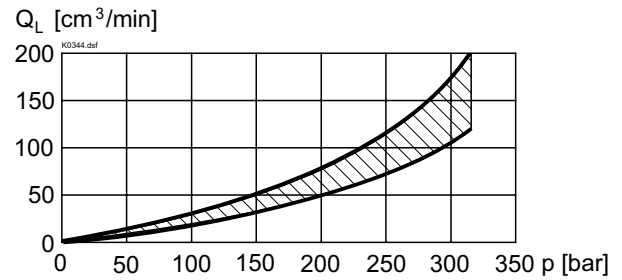
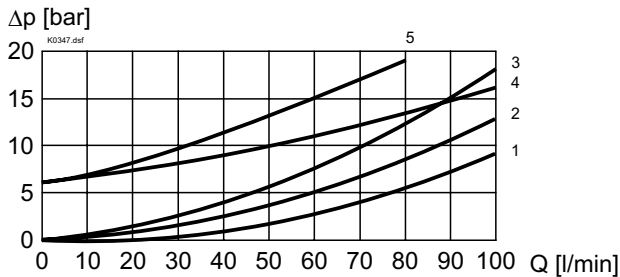
CHARACTERISTICS Oil viscosity $\nu = 30 \text{ mm}^2/\text{s}$
 $p = f(Q)$ Performance limits with standard voltage -10%
 (Solenoid operated)

 $Q_L = f(p)$ Leakage volume flow characteristics per control edge

 $\Delta p = f(Q)$ Pressure drop volume flow characteristics

Pilot supply t_i and p_i

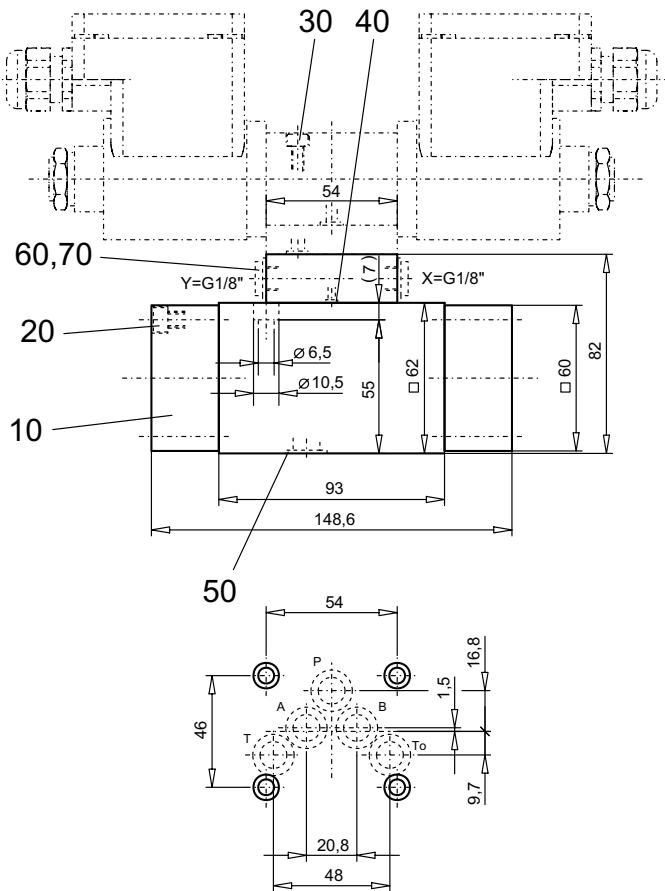
Symbol	Pressure drop curve no.	Volume flow direction				
		P - A	P - B	P - T	A - T	B - T
Z100/J100	1	1	1	-	1	2
D101/Z101	1	1	1	-	1	2
D102/Z102	1	1	1	-	1	2
D103/Z103	4	4	4	5	1	2
D104/Z104	4	4	4	-	1	2
D105/Z105	1	1	1	-	1	2

Pilot supply t_e and p_e

Symbol	Pressure drop curve no.	Volume flow direction				
		P - A	P - B	P - T	A - T	B - T
Z100/J100	1	1	1	-	1	2
D101/Z101	1	1	1	-	1	2
D102/Z102	1	1	1	-	1	2
D103/Z103	1	1	1	3	1	2
D104/Z104	1	1	1	-	1	2
D105/Z105	1	1	1	-	1	2

DIMENSIONS

PARTS LIST

Position	Article	Description
10	059.2206	Cover
20	246.3131	Socket head cap screw M6 x 30 DIN 912
30	246.2150	Socket head cap screw M5 x 50 DIN 912 for pilot supply ti
	246.2170	Socket head cap screw M5 x 70 DIN 912 for pilot supply te, pi and pe
40	160.2052	O-ring ID 5,28 x 1,78
50	160.2140	O-ring ID 14,00 x 1,78
60	238.1202	Plug screw DIN 908 G1/8"
70	049.2102	Bonded seal ID 10,7 x 17 x 1,5

ACCESSORIES

Threaded connecting plates, Multi-flange subplates and Longitudinal stacking system see Reg. 2.9

Technical explanation see data sheet 1.0-100

Mounting instruction

To screw the main valve body ($M_D = 9,5$ Nm, quality 8.8) to the base plate the pilot valve ($M_D = 5,5$ Nm, quality 8.8). must be taken off.