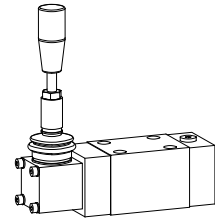

Spool valve
Hand- or roller operated

- 4/2- and 4/3-way detented
- 4/3-way with spring centred mid position
- 4/2-way with spring reset
- $Q_{max} = 60 \text{ l/min}$, $p_{max} = 350 \text{ bar}$

NG6
 ISO 4401-03

DESCRIPTION

Spool valve NG6, flange type in accordance to ISO 4401-03 with 4 connections, directly operated by hand or roller, in 5 chamber system. The hand lever valve is available with locked spool or with spring reset. The dancing roller valve only has a spring reset facility. Precise spool fit, little leakage, long life. Threaded connection by means of additional connecting plate. Hardened steel spool, the valve body being made from a high quality casting suitable for hydraulic applications. The valve body is painted, the end cover and lever housing are phosphatised.

FUNCTION

When actuated, the lever or roller displaces the spool to the corresponding switching position.

- 4/2- and 4/3-way manual valves with spring, 1 lever and 2 or 3 switching positions. The spring presses the spool back into the home position.
- 4/2- and 4/3-way manual lever valve with lock, 1 lever and 2 or 3 switching positions. The lock holds the spool in the last position selected.
- 4/2-way dancing roller valve, 1 dancing roller and 2 switching positions. The spring presses the spool back to the starting position.

APPLICATION

Mechanically operated spool valves are mainly used to control the direction of movement and retain hydraulic cylinders and motors. The direction of movement is determined by the position of the valve spool and its symbol. Mechanically operated valves are particularly suitable for use in installations where no control current is available or for applications in areas where there is a risk of explosion (chemical industry, tunnel construction).

CONTENT

GENERAL SPECIFICATIONS.....	1
HYDRAULIC SPECIFICATIONS.....	1
CONTROL MECHANICAL.....	1
TYPE CHARTS/ SYMBOLS.....	2
CHARACTERISTICS.....	2
DIMENSIONS.....	3
PARTS LIST.....	3
ACCESSORIES.....	3

TYPE CODE

Internationale Interface ISO		A	<input type="checkbox"/>	4	<input type="checkbox"/>	/	<input type="checkbox"/>	#	<input type="checkbox"/>
Operations:	Hand lever <input type="checkbox"/> H								
	Roller <input type="checkbox"/> T								
Number of control ports									
Description of symbols acc. to table		side-a	<input type="checkbox"/> a						
1.5-40/2		side-b	<input type="checkbox"/> b						
Spring return		<input type="checkbox"/> f							
Detented		<input type="checkbox"/> r (only by hand lever operation)							
Design-Index (Subject to change)									

GENERAL SPECIFICATIONS

Description	4/2-, 4/3-way valve
Nominal size	NG6 to ISO 4401-03
Construction	Direct operated spool valve
Operations	Hand operated (hand lever) or roller
Mounting	Flange
	4 fixing holes for socket head cap screws M5 x 45
Connections	Threaded connection plates Multi-flange plates, Manyfolds Longitudinal stacking system
Ambient temperature	-20...50 °C
Mounting position	any, preferable horizontal
Fastening torque	$M_b = 5.5 \text{ Nm}$ (screw quality 8.8)
Weight: Hand lever	$m = 1,55 \text{ kg}$
Roller	$m = 1,50 \text{ kg}$

HYDRAULIC SPECIFICATIONS

Fluid	Mineral oil, other fluid on request
Contamination efficiency	ISO 4406:1999, class 20/18/14 (Required filtration grade $\beta_{10...16} \geq 75$) refer to data sheet 1.0-50/2
Viscosity range	12 mm ² /s...320 mm ² /s
Fluid temperature	-20...+70 °C
Operating pressure in port P, A, B	$p_{max} = 350 \text{ bar}$
Tank pressure in port T	$p_{max} = 100 \text{ bar}$
Max. volume flow	$Q_{max} = 60 \text{ l/min}$
Leakage volume flow	see characteristics

CONTROL MECHANICAL

Angle (Hand lever)	$\alpha_b = 7,7^\circ/\text{side}$
Stroke (roller)	$S_b = 2,7 \text{ mm}$
Force:	
– Hand lever	$F_b = 15 - 20 \text{ N}$
– roller	$F_b = 90 - 120 \text{ N}$

TYPE LIST / DESIGNATION OF SYMBOLS

4/2-way valve with spring reset or detented

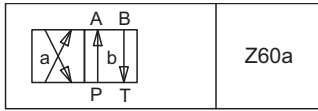

Z60a

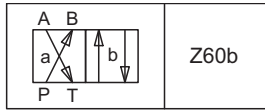

Z60b

Transitional functions

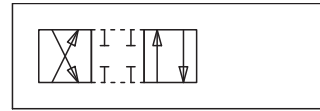

4/3-way valve spring centered or detented (only by hand lever operation)

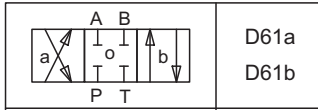

D61a

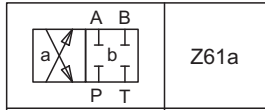

Z61a

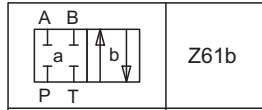

Z61b

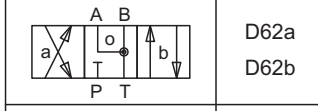
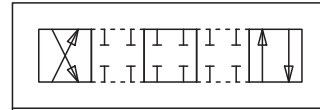

D62a

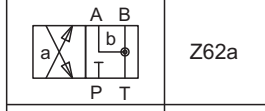

Z62a

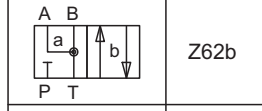

Z62b

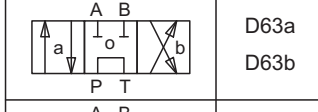
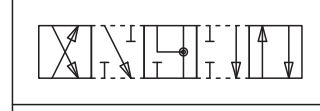

D63a

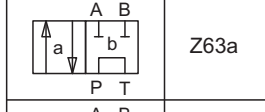

Z63a

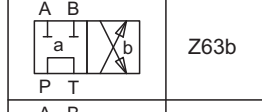

Z63b

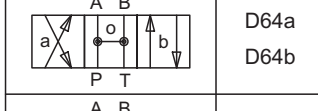
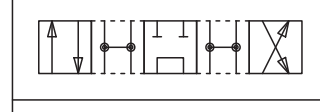

D64a

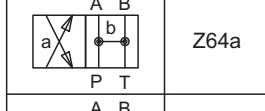

Z64a

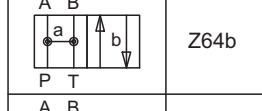

Z64b

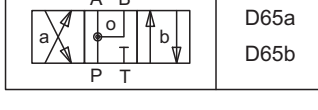
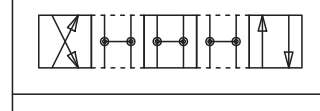

D65a

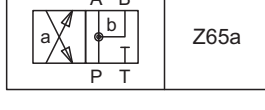

Z65a

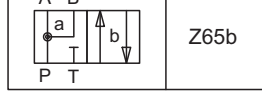

Z65b

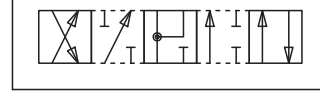
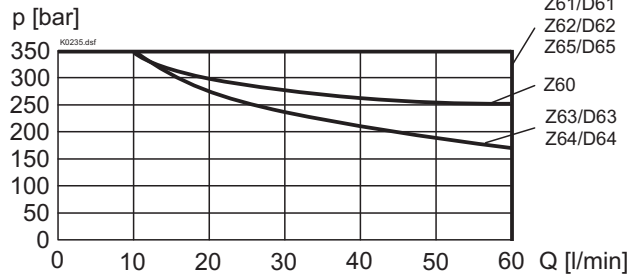
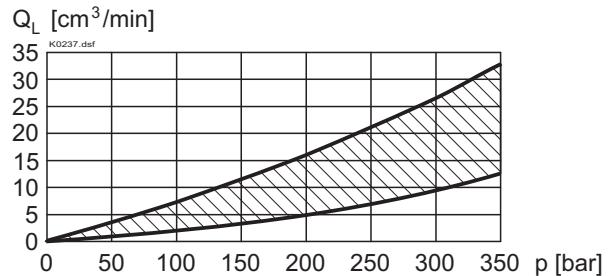
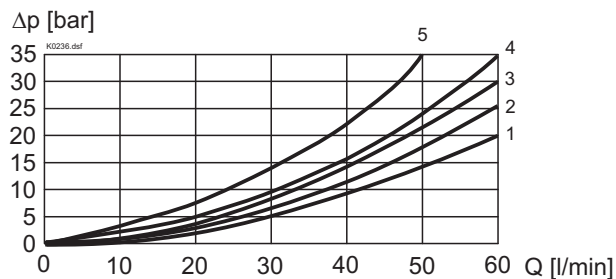
CHARACTERISTICS Oilviscosity $\nu = 30 \text{ mm}^2/\text{s}$
 $p = f(Q)$ Performance limits

 $Q_L = f(p)$ Leakage volume flow characteristics per control edge

 $\Delta p = f(Q)$ Pressure drop volume flow characteristics

Symbol	Volume flow direction				
	P - A	P - B	P - T	A - T	B - T
Z60	3	3	-	4	4
D61/Z61	2	2	-	4	4
D62/Z62	3	3	-	4	4
D63/Z63	2	2	5	3	3
D64/Z64	1	1	-	3	3
D65/Z65	1	1	-	4	4

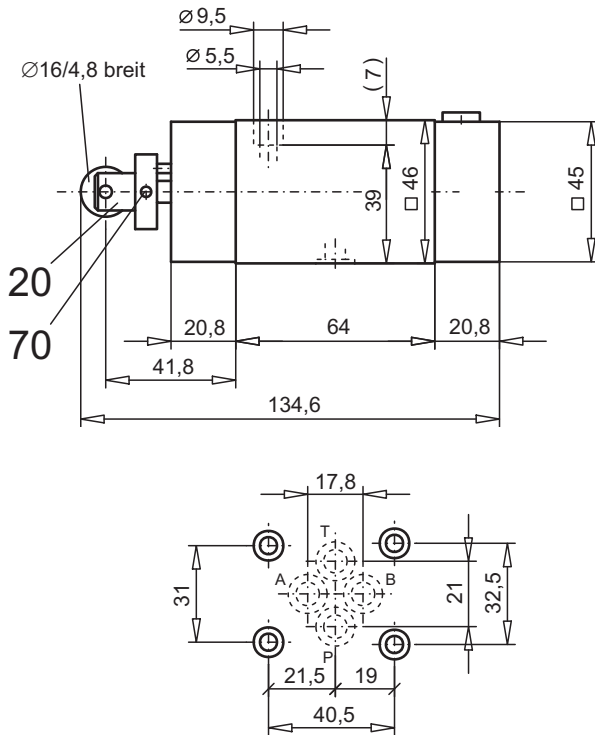
DIMENSIONS

Roller operated

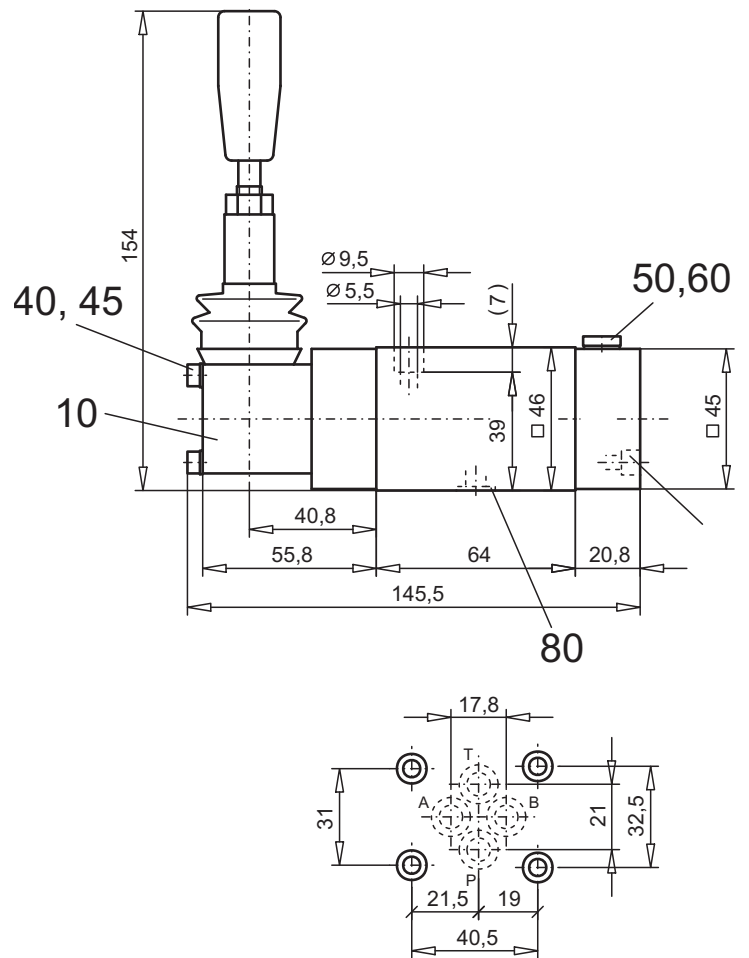

Hand operated

PARTS LIST

Position	Article	Description
10	253.2000	Hand control head BH II
20	253.4100	Mechanical control head AT II
30	246.1120	Socket head cap screw M4 x 20 DIN 912
40	249.1000	Socket head cap screw M4 x 63
45	234.5040	Spring washer M4
50	238.0201	Plug screw galv. M8 x 1 DIN 908 (by spring centred version)
	239.2000	Plug screw (by dedented version)
60	49.1080	Cop. seal ring NG8 x 11,5 x 1 DIN 7603 (only by dedented version)
70	221.2272	Spring tension pin Ø 3 x 16 DIN 1 481
80	160.2093	O-ring ID9,25 x 1,78

ACCESSORIES

 Threaded connection plates, Multi-flange plates
 and longitudinal stacking system

register 2.9

Technical explanation see data sheet 1.0-100