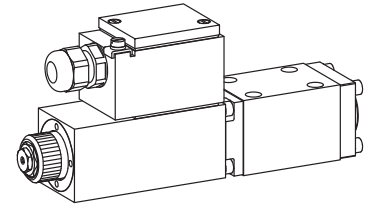

Solenoid operated spool valve intrinsically safe NG6
ATEX and IECEx certified

ISO 4401-03

- 4/2-way impulse valve
- 4/3-way with spring centred mid position
- 4/2-way spring reset
- $Q_{max} = 20 \text{ l/min}$, $p_{max} = 300 \text{ bar}$

Ex ia I Ma
Ex ia II C T5/T6 Ga
II 1 G Ex ia II C T6, T5
I M1 Ex ia I Ma

DESCRIPTION

Spool valve NG6, flange type with 4 ports. Direct operated spool in 5 chamber body. Actuated by an explosion-proof solenoid. Intrinsic safety is achieved by limiting the electric energy in the solenoid supply circuit by means of a separate certified intrinsically safe power supply. Spool detented or with spring reset. Wet pin solenoid, precise spool fit, low leak, long service life. Spool made of hardened steel. Valve body made of high grade hydraulic cast iron.

The solenoid coils are certified in accordance with ATEX and IECEx

Design type test certifications:

PTB 07 ATEX 2059 X

BVS 09 ATEX E 097

IECEx BVS 09.0047

FUNCTION

When energised the solenoid pushes the spool into the corresponding shifted position.

- 4/2-way detented spool valve:
2 solenoids and 2 detented spool positions. With deenergised solenoids, the spool will be held in the corresponding position by the detent.
- 4/3-way spool valve:
2 solenoids and 3 spool positions. With deenergised solenoids the spool will be shifted by the spring into the center position.
- 4/2-way spool valve:
1 solenoid and 2 spool positions. With the deenergised solenoid the spool will be shifted by the spring into the reset position.

APPLICATION

Solenoid operated directional spool valves are mainly used to control the direction of movement and holding of hydraulic cylinders and motors. The direction of movement is defined by the symbol. For the layout of the hydraulic system, leakage and valve performance must be taken into consideration. The valves are designed for areas where flammable gases are present continuously or intermittently. The intrinsically safe electric circuit prevents sparking.

Intrinsically safe valves are used in:

- Shipping- and offshore industry
- Oil- and gas industry
- Chemical industry
- the mining application

CONTENT

GENERAL SPECIFICATIONS.....	1
HYDRAULIC SPECIFICATIONS.....	1
ELECTRICAL CONTROL.....	2
ELECTRIC POWER SUPPLY.....	2
SAFETY RELEVANT DATA.....	2
SAFE OPERATION.....	2
TYPE LIST/ DESIGNATION OF SYMBOLS.....	2
CHARACTERISTICS.....	3
DIMENSIONS.....	4
PARTS LIST.....	4
ACCESSORIES.....	4

TYPE CODE

	A EXi 4 - 100 / T6 #
International mounting interface standard ISO	
Explosion proof solenoid intrinsically safe	
Number of control ports	
Description of symbols acc. to table 1.3-40/2	
Coil resistance 100 Ω (other on request)	
Execution T1...T6	
Design-Index (Subject to change)	

GENERAL SPECIFICATIONS

Designation	4/2-, 4/3-spool valve
Nominal size	NG6 according to ISO 4401-03
Construction	Direct operated spool valve
Operation	Solenoid
Mounting	Flange 4 fixing holes for socket head cap screws M5x45
Connections	Threaded connection plates Multi-flange subplates Longitudinal stacking system
Admissible ambient temp.	-20...+45 °C (operation as T6) -20...+60 °C (operation as T1...T5)
Mounting position	any, preferable horizontal
Fastening torque	$M_b = 5,5 \text{ Nm}$ (quality 8.8)
Masse: 4/2-way impulse	$m = 5,3 \text{ kg}$
4/3-way	$m = 5,3 \text{ kg}$
4/2-way (1 solenoid)	$m = 3,2 \text{ kg}$

HYDRAULIC SPECIFICATIONS

Fluid	Mineral oil, other fluid on request
Contamination efficiency	ISO 4406:1999, class 20/18/14 (Required filtration grade $\beta_{10...16} \geq 75$) refer to data sheet 1.0-50/2
Viscosity range	12 mm ² /s...320 mm ² /s
Admissible fluid temperature	-20...+45 °C (operation as T6) -20...+60 °C (operation as T1...T5)
Working pressure in port P, A, B	$p_{max} = 300 \text{ bar}$
Tank pressure in port T	$p_{max} = 100 \text{ bar}$
Max. volume flow	$Q_{max} = 20 \text{ l/min}$
Leakage volume flow	see characteristics

ELECTRICAL CONTROL

Construction	Solenoid, wet pin push type, pressure tight
Protection class	IP65 acc. to EN 60 529 (after correct installation)
Duty time	Continuous
Switching cycles	1800/h
Life time	10 ⁷ (cycles per solenoid, theoretically)
Connection/power supply	Cable entry for cable Ø 6...12 mm 2 leads for +/- and 1 for ground
Temperature class	T1...T6 to EN 60 079-0
Slip-on coil	rotatable in steps of 90°, easily exchangeable
Other electrical specifications	see data sheet 1.1-185 (M.Z45)

SAFETY RELEVANT DATA

Technical safety limit values	Device group	I	II
	U _i	30 V	30 V
	I _i	2,5 A	0,8 A
	P _i		3 W
	L _i	0mH	0mH
	C _i	0nF	0nF
Coil resistance	The inductance and capacitance of the solenoid coils are made ineffective. 100 Ω		
Power supply	Suitable power supplies are available on the market or may be supplied on request.		
Solenoid current	Solenoid current available from the power supply must exceed 0,81W (90 mA mit 100 Ω).		

RECOMMENDED ELECTRIC POWER SUPPLY FOR DEVICE GROUP II

available on the free market (GEORGIN)

Electric power supply type for 4/2-way directional control valve BXNE3412 or BXNE3712 (1 channel, 1 control input, 24...48 VDC)

Electric power supply type for 4/3-way directional control valve BXNE3422 or BXNE3722 (2 channels, 2 control inputs, 24...48 VDC)

 Output current at 100 Ω 95 mA for type 34
 Load resistance and Nominal voltage 125 mA for type 37
 (load resistance = coil resistance + cable resistance)

 Device designation according to ATEX  II 1G/D EEx ia II C

Supply voltage for the electric power supply 24...48 VDC, 110 VAC, 230 VAC available

SAFE OPERATION

Intrinsically safe valves must be operated from suitable, certified power supplies which are located outside the hazardous area (see operating instructions). The selection of the power supply and wiring work must be executed by trained specialists.

TYPE LIST / DESIGNATION OF SYMBOLS

4/2-way valve impulse

 4/2-way valve with spring reset
 Operation A-side

Operation B-side

Transitional functions

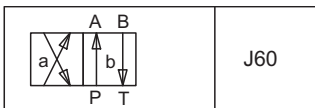

J60

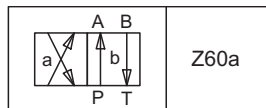

Z60a

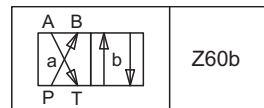

Z60b

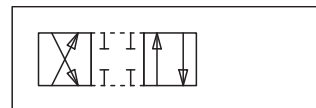

4/3-way valve spring centred

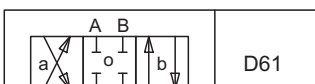

D61

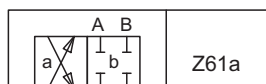

Z61a

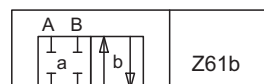

Z61b

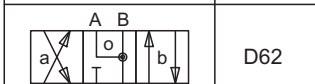
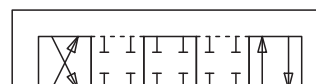

D62

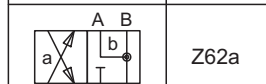

Z62a

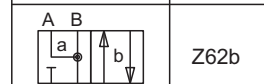

Z62b

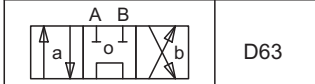
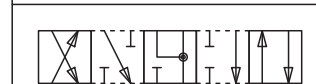

D63

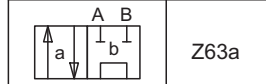

Z63a

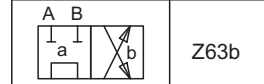

Z63b

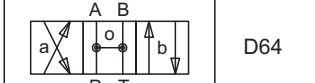

D64

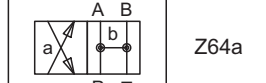

Z64a

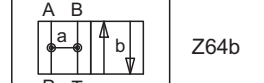

Z64b

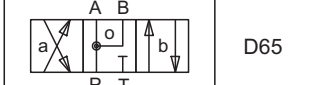
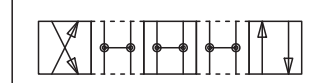

D65

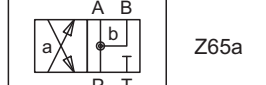

Z65a

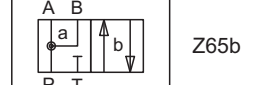

Z65b

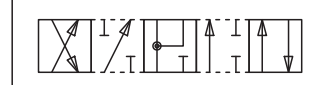

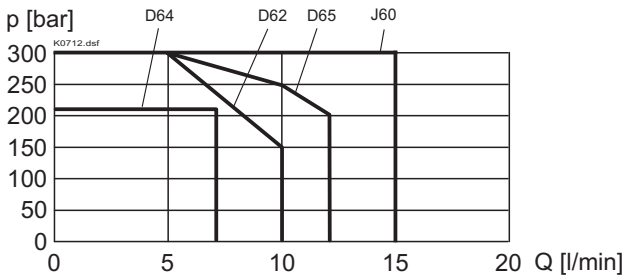
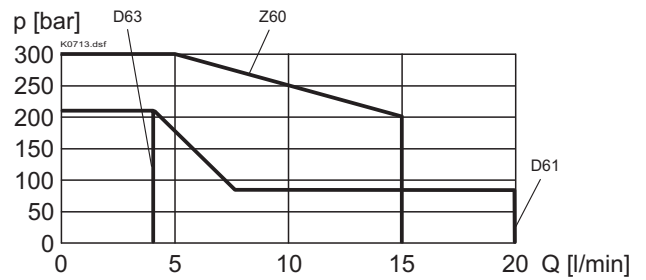
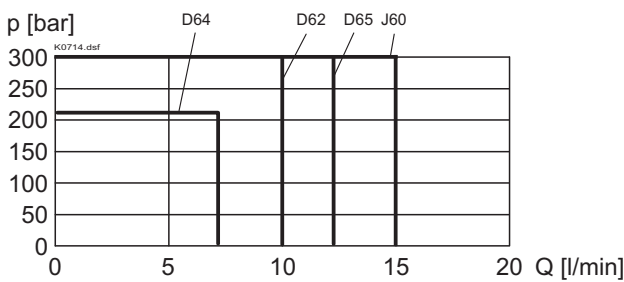
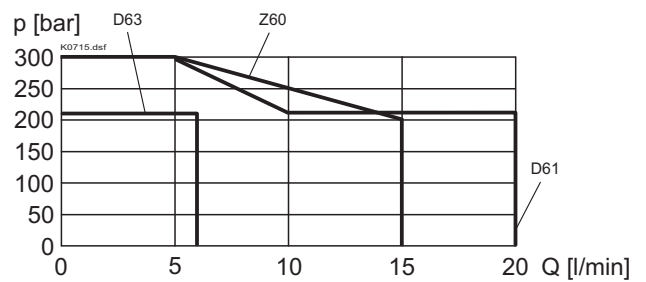
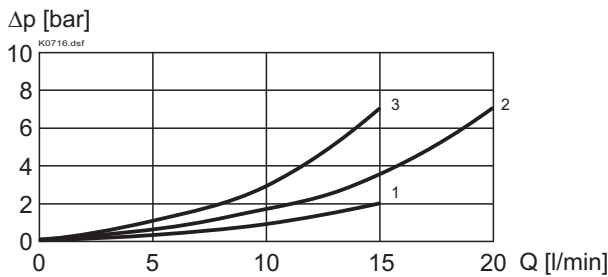
CHARACTERISTICS Oil viscosity $\nu = 30 \text{ mm}^2/\text{s}$
 $p = f(Q)$ Performance limit with $P_{\min} = 0,81 \text{ W}$ (90 mA, 100 Ω)

 $p = f(Q)$ Performance limit with $P_{\min} = 0,81 \text{ W}$ (90 mA, 100 Ω)

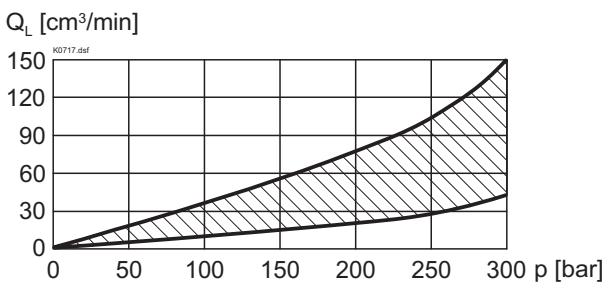
 $p = f(Q)$ Performance limit with $P \geq 1,21 \text{ W}$ (110 mA, 100 Ω)

 $p = f(Q)$ Performance limit with $P \geq 1,21 \text{ W}$ (110 mA, 100 Ω)

 $\Delta p = f(Q)$ Pressure drop volume flow characteristics

Symbol	Pressure drop curve no.	Volume flow direction				
		P - A	P - B	P - T	A - T	B - T
Z60	3	3	3	-	3	3
J60	2	2	2	-	2	2
D61/Z61	2	2	2	-	2	2
D62/Z62	2	2	2	-	1	1
D63/Z63	3	3	3	2	3	3
D64/Z64	1	1	1	-	1	1
D65/Z65	1	1	1	-	2	2

 $Q_L = f(p)$ Leakage volume flow characteristics per control edge

DIMENSIONS

 4/3-way valve (spring centred)
 4/2-way valve (impulse)

4/2-way valve (spring reset)

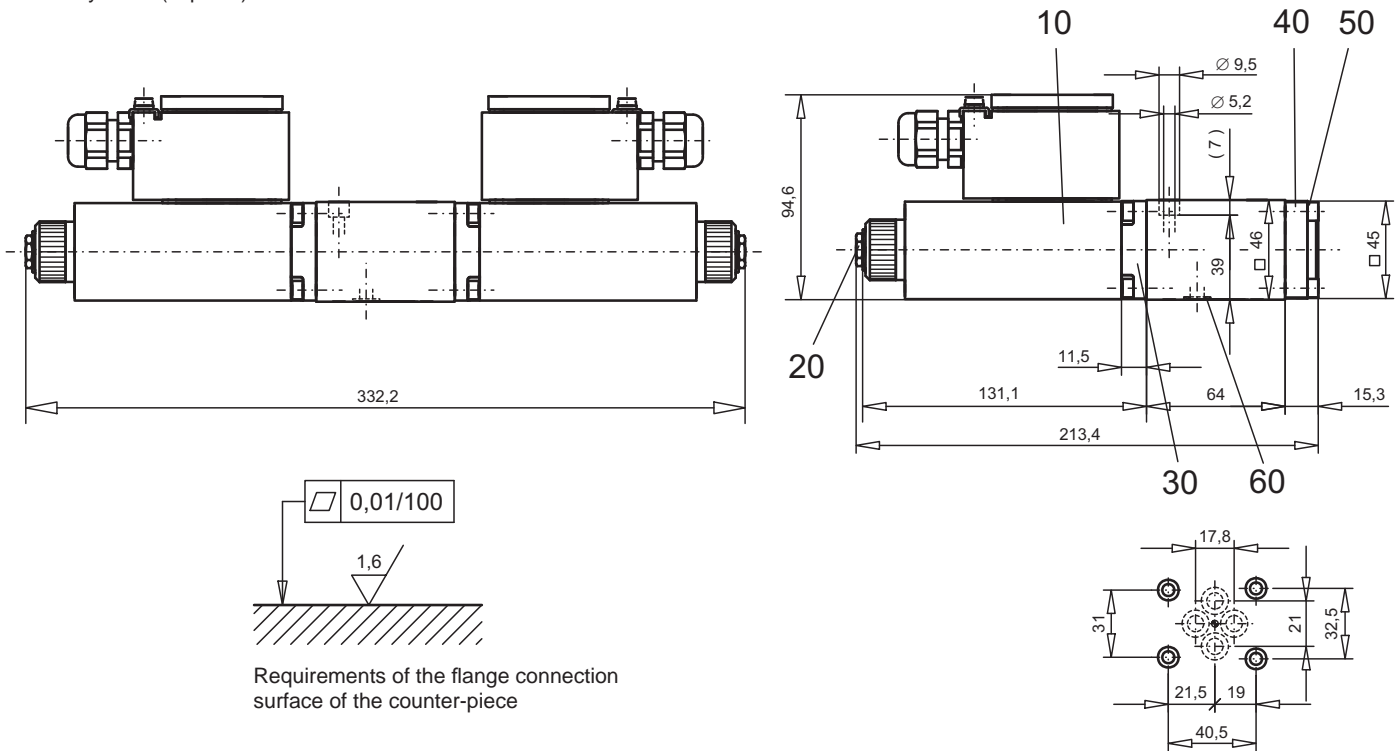
PARTS LIST

Position	Article	Description
10	263.6...	Solenoid coil type MKZ45
20	253.8000	plug with integrated manuel override HB4,5
30	260.0093	Armature tube SMI45
40	058.4211	Cover
50	246.1117	Socket head cap screw M5x16 DIN 912
60	160.2093	O-ring ID 9,25x1,78

ACCESSORIES

Threaded connecting plates, multi-flange subplates and longitudinal stacking system see register 2.9

Technical explanation see data sheet 1.0-100E