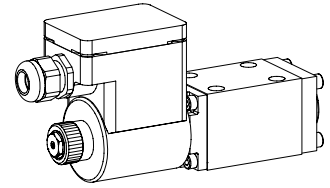

Solenoid operated spool valve

- 4/2-way impulse valve
- 4/3-way with spring centred mid position
- 4/2-way spring reset
- $Q_{max} = 50 \text{ l/min}$, $p_{max} = 350\text{bar}$

NG6
 ISO 4401-03

II 2 G / II 2 D
EEx em II

DESCRIPTION

Spool valve flange type NG6 with 4 connections. Direct solenoid operated spool valve with a 5 annular chamber body design. Activated with explosion proof solenoid. Spool detented or with spring reset. Wet pin solenoid. Precise spool fit, low leak, long service life. Spool made from hardened steel. Valve body made from high grade hydraulic cast iron.

EEx: in accordance with european standards EN 50014, EN 50019, EN 50028

e: increased safety

m: encapsulation

Group II:

for all applications except mining

Zone 1/21 (and 2/22):

explosive mixtures present intermittently

EC-type examination certificate:

PTB 01 ATEX 2129 X

FUNCTION

The energised solenoid shifts the spool into the corresponding position.

• 4/2-way impulse valve detented:

Two solenoids and 2 detented positions. With the solenoid deenergised the spool remains in the last switched position.

• 4/3-way spool valve:

Two solenoids and 3 positions, spring centered. With the solenoids deenergised the spool returns to the center position by spring force.

• 4/2-way spool valve:

One solenoid and 2 positions, spring offset. With the solenoid deenergised the spool returns to the offset position by spring force.

APPLICATION

Solenoid operated spool valves are mainly used to control the direction of movement and retain hydraulic cylinders and motors. The direction of flow through the valve is determined by the spool symbol. Switching performance and possible leakage must be taken into consideration when designing a system. These valves are suitable for hazardous areas in off-shore and ship-building applications as well as in chemical, oil and gas industry.

CONTENT

GENERAL SPECIFICATIONS	1
HYDRAULIC SPECIFICATIONS	1
ELECTRICAL CONTROL	2
SOLENOID DESCRIPTION	2
TYPE LIST/ DESIGNATION OF SYMBOLS	2
CHARACTERISTICS	2/3
DIMENSIONS	3
PARTS LIST	3
ACCESSOIRES	3

TYPE CODE

	A	EX	4		- S1788 -		/		#	
International mounting interface ISO										
Explosion proof solenoid										
Number of control ports										
Description of symbols acc. to table 1.3-31/2										
Terminal box without cable										
Standard nominal voltage U_N :	24 VDC	<input type="checkbox"/>	G24							
	115 VAC	<input type="checkbox"/>	R115							
	230 VAC	<input type="checkbox"/>	R230							
Execution:	T1...T4	<input type="checkbox"/>	T4							
	T1...T6	<input type="checkbox"/>	T6							(on request)
Design-Index (Subject to change)										

GENERAL SPECIFICATIONS

Description	4/2-, 4/3-spool valve
Nominal size	NG6 to ISO 4401-03
Construction	Direct operated spool valve
Operation	Solenoid
Mounting	Flange
	4 fixing holes for cyl. screws M5x45
	M5x60 with distance plate ADP6/12
Connections	Threaded connection plates
	Multi-flange subplates
	Longitudinal stacking system
Admissible ambient temp.*:	
Execution T4	-20...+40°C
Execution T6	-20...+70°C (operation as T1...T4)
	-20...+40°C (operation as T5/T6)
Mounting position	any, preferably horizontal
Fastening torque	$M_f = 5,5 \text{ Nm}$ (quantity 8.8)
Weight: 4/2-way impulse	$m = 3,0 \text{ kg}$
4/3-way	$m = 3,0 \text{ kg}$
4/2-way (1 solenoid)	$m = 2,0 \text{ kg}$

HYDRAULIC SPECIFICATIONS

Fluid	Mineral oil, other fluid on request
Contamination efficiency	ISO 4406:1999, classe 20/18/14 (Required filtration grade $\beta_{10...16} \geq 75$) refer to data sheet 1.0-50/2
Viscosity range	12 mm ² /s...320 mm ² /s
Admissible fluid temp.*:	
Execution T4	-20...+40°C
Execution T6	-20...+70°C (operation as T1...T4)
	-20...+40°C (operation as T5/T6)
Working pressure	$p_{max} = 350\text{bar}$
in port P, A, B	
Tank pressure	$p_{max} = 100 \text{ bar}$
in port T	
Max. volume flow	$Q_{max} = 50 \text{ l/min}$
Leakage volume flow	see characteristics

* Deviating pressure medium - or ambient temperatures are possible for special arrangements after checking and authorisation by a responsible inspector. Measures for the prevention of the exceeding of the admissible solenoid surface - and internal temperatures can be: a good ventilation, low ambient temperatures (for higher pressure medium temperatures), limitation of the maximum possible power supply voltage, a short switching-on duration, installation on large heat dissipating blocks, etc. The responsibility in all cases lies with the operator, resp. with his inspector.

ELECTRICAL CONTROL



Construction	Solenoid, wet pin push type, pressure tight	Switching cycles	12000/h
Standard-nominal voltage	$U_N = 24$ VDC $U_N = 115$ VAC, $U_N = 230$ VAC DC: max. allowed ripple 20%, wired with VDR AC: 50 to 60 Hz $\pm 2\%$, with half wave rectifier and recovery diode	Operating life	10^7 (number of switching cycles, theoretically)
Voltage tolerance	$\pm 10\%$ of rated voltage	Connection/Power supply	Through cable entry for cable diameter 6...12 mm
Protection class	IP65/IP67 acc. to EN 60529	Designation	
Relative duty factor	100% DF	Execution T4:	II 2 G EEx em II T4 (for gas) II 2 D IP65 T130°C (for dust)
		Execution T6:	II 2 G EEx em II T6 (for gas) II 2 D IP65 T80°C (for dust)
		Nominal power	
		Execution T4:	17 W (DC), 23 VA (AC)
		Execution T6:	7 W (DC), 11 VA (AC)

START-UP

1. In the power supply for each solenoid a fuse of an appropriate rating (max. 3 times I_b of solenoid, DIN 41571 or IEC 127) respectively a motor circuit breaker with electromagnetic and thermal interruption must be installed. The fuse may be located in the power supply unit for the solenoid or between power supply and solenoid. The voltage rating for the fuse must be equal or higher than the one for the solenoid.

2. The solenoid coils must only be operated on the valve belonging to them. More information concerning the installation and commissioning is contained in the operating instructions supplied together with the solenoid coil.

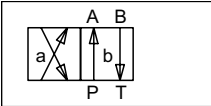
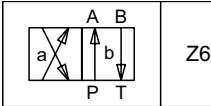
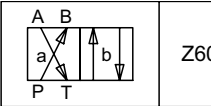
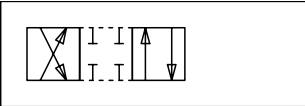
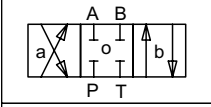
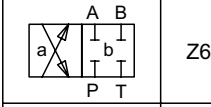
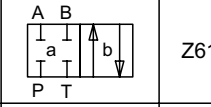
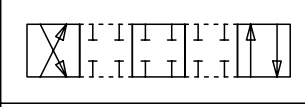
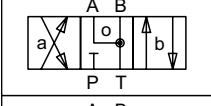
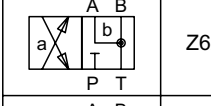
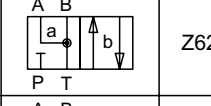
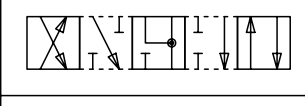
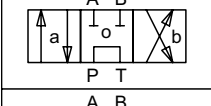
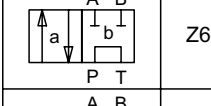
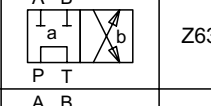
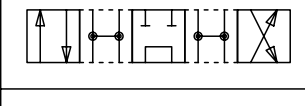
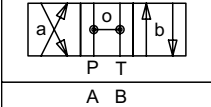
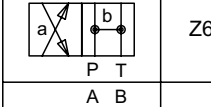
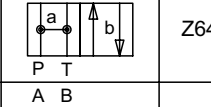
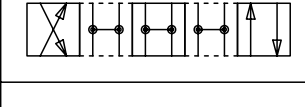
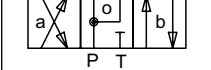
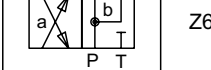
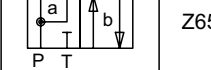
TYPE LIST / DESIGNATION OF SYMBOLS

4/2-way valve impulse	4/2-way valve with spring reset Operation A-side	Operation B-side	Transitional functions
 J60	 Z60a	 Z60b	
4/3-way valve spring centred			
 D61	 Z61a	 Z61b	
 D62	 Z62a	 Z62b	
 D63	 Z63a	 Z63b	
 D64	 Z64a	 Z64b	
 D65	 Z65a	 Z65b	

CHARACTERISTICS (T6 on request) Oil viscosity $\nu = 30$ mm²/s

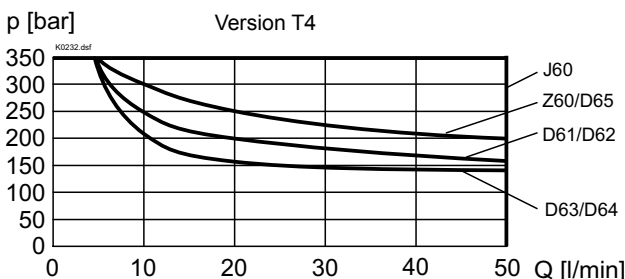

$p = f(Q)$ Performance limits with standard voltage -10%

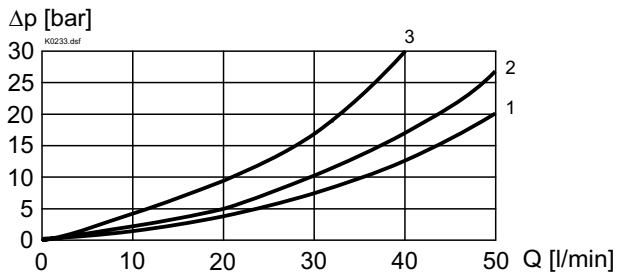

$\Delta p = f(Q)$ Pressure drop volume flow characteristics

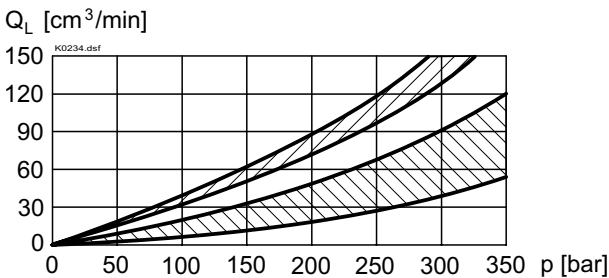
Pressure drop Curve no.	Volume flow direction				
	P - A	P - B	P - T	A - T	B - T
Z60/J60	2	2	-	2	2
D61/Z61	2	2	-	2	2
D62/Z62	2	2	-	2	2
D63/Z63	2	2	3	2	2
D64/Z64	1	1	-	1	1
D65/Z65	1	1	-	2	2

 $Q_L = f(p)$ Leakage volume flow characteristics per control edge

-  Envelop curve for spool no. 3
-  Envelop curve for the remaining spool

DIMENSIONS

 4/3-way valve (spring centred)
 4/2-way valve (impulse)

4/2-way valve (spring offset)

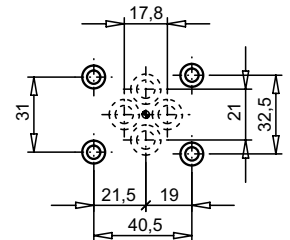
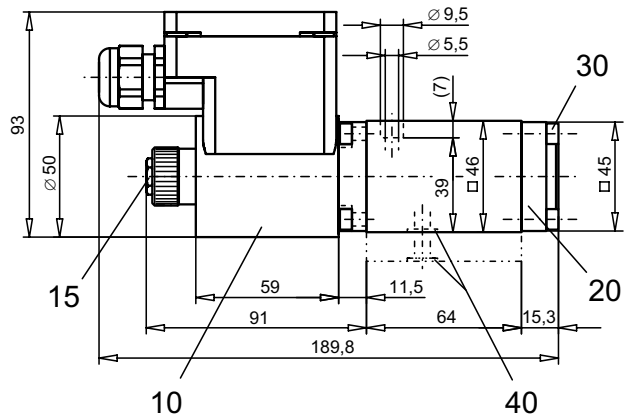
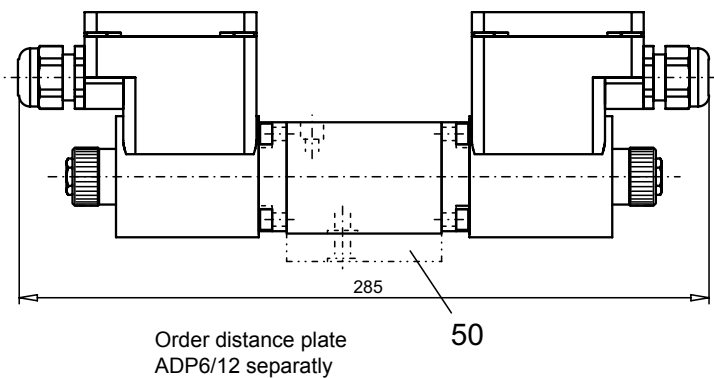
PARTS LIST

Position	Article	Description
10	207.5...	Coil type EExem
15	253.8000	plug with integrated manual override HB4,5
20	058.4200	Cover
30	246.2117	Socket head cap screw M5x16 DIN 912
40	160.2093	O-Ring ID 9,25x1,78
50	173.3451	Distance plate ADP6/12

ACCESSORIES

Threaded connecting plates, Multi-flange subplates and Longitudinal stacking system see Reg. 2.9

Technical explanation see data sheet 1.0-100