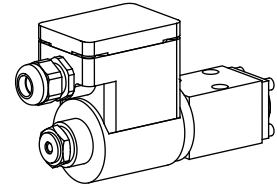

**Solenoid operated spool valve**

- 4/2-way impulse valve
- 4/3-way with spring centred mid position
- 4/2-way spring reset
- $Q_{max} = 20 \text{ l/min}$ ,  $p_{max} = 315 \text{ bar}$

**DESCRIPTION**

Spool valve flange type NG4-Mini with 4 connections. Direct solenoid operated spool valve with a 5 annular chamber body design. Activated with explosion proof solenoid. Spool detented or with spring reset. Wet pin solenoid. Precise spool fit, low leak, long service life. Spool made from hardened steel. Valve body made from high grade hydraulic cast iron.

**EEx:** in accordance with european standards EN 50014, EN 50019, EN 50028

**e:** increased safety

**m:** encapsulation

**Group II:**

for all applications except mining

**Zone 1 / 21** (and 2/22):

explosive mixtures present intermittently

**EC-type examination certificate:**

PTB 01 ATEX 2129 X

**FUNCTION**

The energised solenoid shifts the spool into the corresponding position.

• 4/2-way impulse valve detented:

Two solenoids and 2 detented positions. With the solenoid deenergised the spool remains in the last switched position.

• 4/3-way spool valve:

Two solenoids and 3 positions, spring centered. With the solenoids deenergised the spool returns to the center position by spring force.

• 4/2-way spool valve:

One solenoid and 2 positions, spring offset. With the solenoid deenergised the spool returns to the offset position by spring force.

**APPLICATION**

Solenoid operated spool valves are mainly used to control the direction of movement and retain hydraulic cylinders and motors. The direction of flow through the valve is determined by the spool symbol. Switching performance and possible leakage must be taken into consideration when designing a system. These valves are suitable for hazardous areas in off-shore and ship-building applications as well as in chemical, oil and gas industry.

**CONTENT**

GENERAL SPECIFICATIONS .....	1
HYDRAULIC SPECIFICATIONS .....	1
ELECTRICAL CONTROL .....	2
SOLENOID DESCRIPTION .....	2
TYPE LIST/ DESIGNATION OF SYMBOLS .....	2
CHARACTERISTICS .....	2/3
DIMENSIONS .....	3
PARTS LIST .....	3
ACCESSOIRES .....	3

**TYPE CODE**

	B	EX	4		- S1788 -		/		#	
Interface										
Explosion proof solenoid										
Number of control ports										
Description of symbols acc. to table 1.3-21/2										
Terminal box without cable										
Standard-nominal voltage $U_N$ :	24 VDC	<input type="checkbox"/>	G24							
	115 VAC	<input type="checkbox"/>	R115							
	230 VAC	<input type="checkbox"/>	R230							
Execution:	T1...T4	<input type="checkbox"/>	T4							
	T1...T6	<input type="checkbox"/>	T6							
Design-Index (Subject to change)										

**GENERAL SPECIFICATIONS**

Description	4/2-, 4/3-spool valve
Nominal size	NG4-Mini to Wandfluh-standard
Construction	Direct operated spool valve
Operation	Solenoid
Mounting	Flange
	3 fixing holes for socket head cap screws M5x40
	M5x50 with distance plate BDP4/12
Connections	Threaded connection plates
	Multi-flange subplates
	Longitudinal stacking system
Admissible ambient temp. *:	
Execution T4	-20...+40 °C
Execution T6	-20...+70 °C (operation as T1...T4)
	-20...+40 °C (operation as T5/T6)
Mounting position	any, preferably horizontal
Fastening torque	$M_D = 5,5 \text{ Nm}$ (quality 8.8)
Weight:	
	4/2-way impulse $m = 2,6 \text{ kg}$
	4/3-way $m = 2,6 \text{ kg}$
	4/2-way (1 solenoid) $m = 1,8 \text{ kg}$

**HYDRAULIC SPECIFICATIONS**

Fluid	Mineral oil, other fluid on request
Contamination efficiency	ISO 4406:1999, classe 20/18/14 (Required filtration grade $\beta_{10...16} \geq 75$ ) refer to data sheet 1.0-50/2
Viscosity range	12 mm <sup>2</sup> /s...320 mm <sup>2</sup> /s
Admissible fluid temp. *:	
Execution T4	-20...+40 °C
Execution T6	-20...+70 °C (operation as T1...T4)
	-20...+40 °C (operation as T5/T6)
Working pressure in port P, A, B	$p_{max} = 315 \text{ bar}$
Tank pressure in port T	$p_{max} = 100 \text{ bar}$
Max. volume flow	$Q_{max} = 20 \text{ l/min}$
Leakage volume flow	see characteristics

\* Deviating pressure medium - or ambient temperatures are possible for special arrangements after checking and authorisation by a responsible inspector. Measures for the prevention of the exceeding of the admissible solenoid surface - and internal temperatures can be: a good ventilation, low ambient temperatures (for higher pressure medium temperatures), limitation of the maximum possible power supply voltage, a short switching-on duration, installation on large heat dissipating blocks, etc. The responsibility in all cases lies with the operator, resp. with his inspector.

**ELECTRICAL CONTROL**

Construction	Solenoid, wet pin push type, pressure tight	Switching cycles	12000/h
Standard-nominal voltage	$U_N = 24 \text{ VDC}$ $U_N = 115 \text{ VAC}, U_N = 230 \text{ VAC}$ DC = Ripple 20%, wired with VDR AC = 50 bis 60 Hz $\pm 2\%$ ; with half wave rectifier and recovery diode	Operating life	$10^7$ (number of switching cycles, theoretically)
Voltage tolerance	$\pm 10\%$ of rated voltage	Connection/Power supply	Through cable entry for cable diameter 6...12 mm
Protection class	IP65/IP67 acc. to EN 60529	Designation	
Relative duty factor	100% DF	Execution T4:	II 2 G EEx em II T4 (for gas) II 2 D IP65 T130 °C (for dust)
		Execution T6:	II 2 G EEx em II T6 (for gas) II 2 D IP65 T80 °C (for dust)
		Nominal power	
		Execution T4:	17 W (DC), 23 VA (AC)
		Execution T6:	7 W (DC), 11 VA (AC)

**START-UP**

1. In the power supply for each solenoid a fuse of an appropriate rating (max. 3 times  $I_b$  of solenoid, DIN 41571 or IEC 127) respectively a motor circuit breaker with electromagnetic and thermal interruption must be installed. The fuse may be located in the power supply unit for the solenoid or between power supply and solenoid. The voltage rating for the fuse must be equal or higher than the one for the solenoid.

2. The solenoid coils must only be operated on the valve belonging to them. More information concerning the installation and commissioning is contained in the operating instructions supplied together with the solenoid coil.

**TYPE LIST/DESIGNATION OF SYMBOLS**

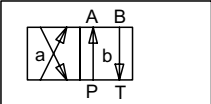
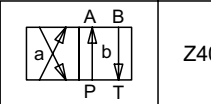
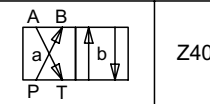
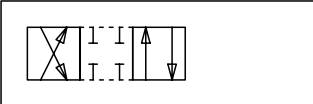
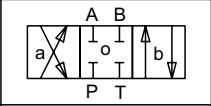
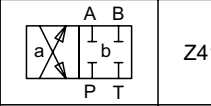
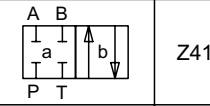
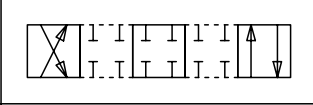
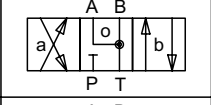
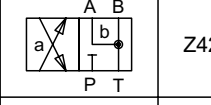
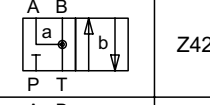
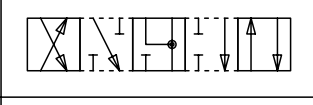
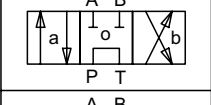
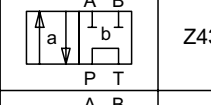
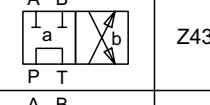
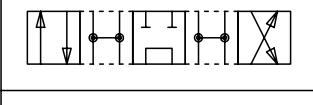
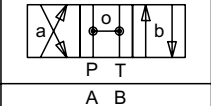
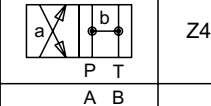
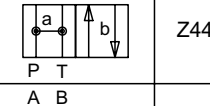
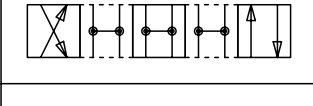
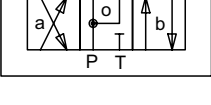
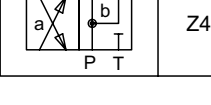
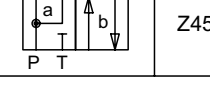
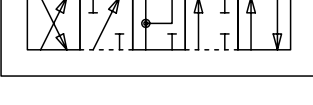
4/2-way valve impulse	4/2-way valve with spring reset operation A-side	operation B-side	Transitional functions
 J40	 Z40a	 Z40b	
<b>4/3-way valve spring centred</b>			
 D41	 Z41a	 Z41b	
 D42	 Z42a	 Z42b	
 D43	 Z43a	 Z43b	
 D44	 Z44a	 Z44b	
 D45	 Z45a	 Z45b	

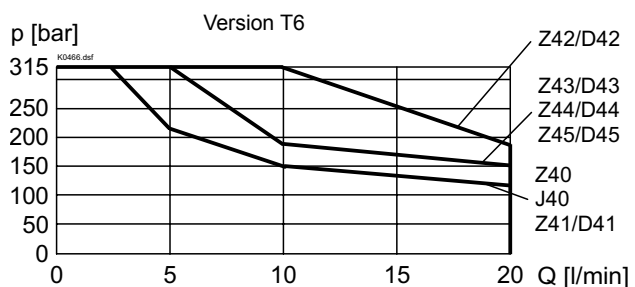
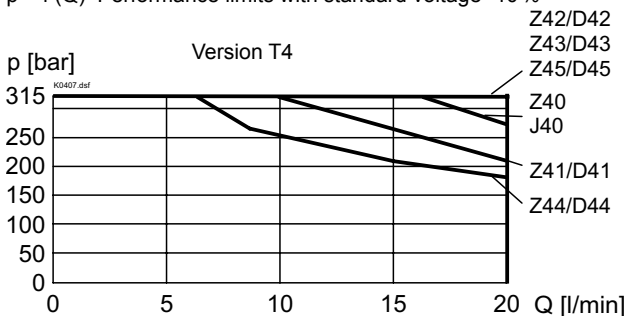

**CHARACTERISTICS** Oil viscosity  $\nu = 30 \text{ mm}^2/\text{s}$ 

$p = f(Q)$  Performance limits with standard voltage -10%

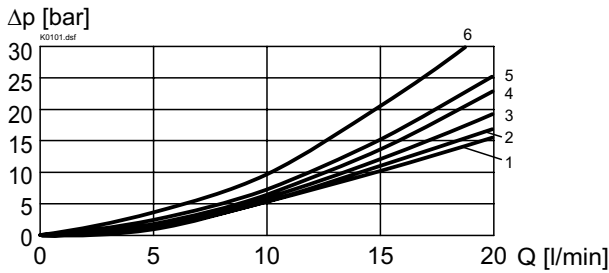

$\Delta p = f(Q)$  Pressure drop volume flow characteristics

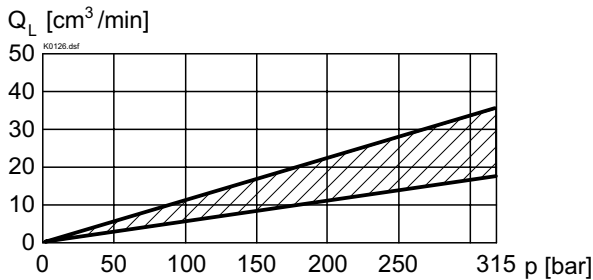
Symbol	Pressure drop Curve no.	Volume flow direction				
		P-A	P-B	P-T	A-T	B-T
Z40/J40	5	5	-	2	2	
Z41/D41	5	5	-	2	2	
Z42/D42	5	5	-	1	1	
Z43/D43	4	4	6	2	2	
Z44/D44	4	4	3	2	2	
Z45/D45	4	4	-	2	2	

 $Q_L = f(p)$  Leakage volume flow characteristics per control edge

 Envelop curve for spool J40/Z40/D41/D42/D44/D45

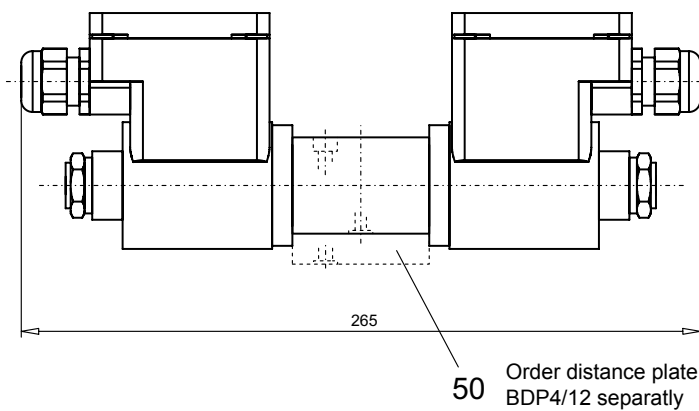
**DIMENSIONS**

 4/3-way valve (spring centred)  
 4/2-way valve (impulse)

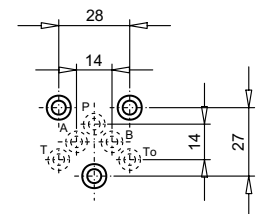
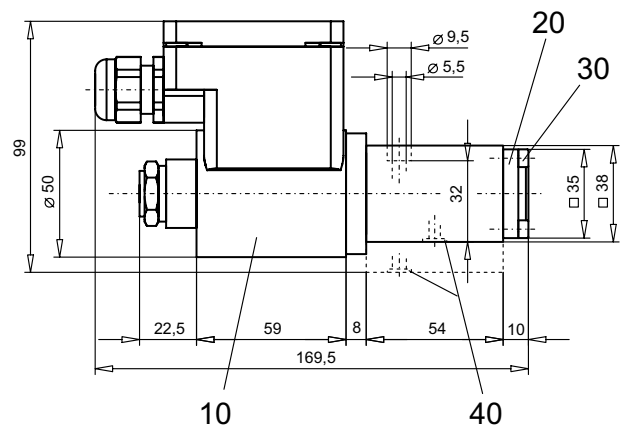
4/2-way valve (spring offset)

**PARTS LIST**

Position	Article	Description
10	207.5...	Coil type EExem
20	57.4202	Cover
30	246.1113	Socket head cap screw M4x12 DIN 912
40	160.2052	O-ring ID 5,28x1,78
50	173.1450	Distance plate BDP4/12

**ACCESSORIES**

Threaded connecting plates, Multi-flange subplates and Longitudinal stacking system see Reg. 2.9

Technical explanation see data sheet 1.0-100