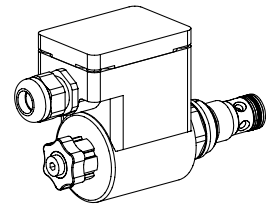

**Solenoid poppet valve cartridge  
2/2-way version**

- Pilot operated
- $Q_{max} = 80 \text{ l/min}$
- $p_{max} = 350 \text{ bar}$

**M22x1,5**  
 ISO 7789

**II 2 G / II 2 D**  
**EEx em II T4**

**DESCRIPTION**

Pilot operated 2/2-way solenoid poppet valve in screw-in cartridge design with thread M22 x1,5 for cavity acc. to ISO 7789.

**EEx:** in accordance with European standards EN 50014, EN 50019, EN 50028

**e:** increased safety

**m:** encapsulation

**Group II:**

for all applications except mining

**Zone 1/21** (and 2/22):

explosive mixtures present intermittently

**EC-type examination certificate:**

PTB 01 ATEX 2129 X

**FUNCTION**

For the function «normally closed» with deenergised pull-type solenoid, and «normally open» with energised push-type solenoid, the differential area poppet piston is held in closed position by a spring and seals leak free from port 2 to 1. If pull-type solenoid is energised respectively push-type solenoid deenergised, the poppet piston will open flow passage from 2 to 1 after having reached the opening pressure. In the «normally closed» valve with deenergised solenoid respectively the «normally open» valve with energised solenoid flow passage from 1 to 2 is open when the opening pressure has been reached.

**APPLICATION**

Wandfluh solenoid operated poppet valves are applied where an absolutely leak free closing of the valve is essential like in load holding-, clamping- or gripping functions. These valves are suitable for hazardous areas in off-shore and shipbuilding applications as well as in the chemical-, oil- and gas industry. The screw-in cartridges are mainly used in mobile or stationary integrated blocks and in size NG4-Mini and NG6 flange and sandwich bodies. To machine the cavities in steel or aluminium blocks, cavity tools may be supplied (hire or purchase). Please refer to the data sheets in register 2.13.

**CONTENT**

GENERAL SPECIFICATIONS .....	1
HYDRAULIC SPECIFICATIONS .....	1
SYMBOLS .....	1
ELECTRICAL CONTROL .....	2
START-UP .....	2
CHARACTERISTICS .....	2
DIMENSIONS/ SECTIONAL DRAWING .....	2
PARTS LIST .....	2
ACCESSORIES .....	2

**TYPE CODE**

	S	V	X	PM22	-		-		/	T4	#	
Poppet valve												
Pilot operated												
Explosion proof solenoid EEx em												
Screw-in cartridge M22x1,5												
2/2-way, «normally closed»												
2/2-way, «normally open»												
Standard-nominal voltage $U_N$ :												
24 VDC												
115 VAC												
230 VAC												
Execution T1...T4												
Design-Index (Subject to change)												

**GENERAL SPECIFICATIONS**

Description	Pilot operated 2/2-way solenoid poppet valve
Construction	Screw-in cartridge for cavity acc. to ISO 7789
Operation	Solenoid
Mounting	Screw-in thread M22 x 1,5
Admissible ambient temperature *	-20...+40°C
Mounting position	any, preferably horizontal
Fastening torque	$M_D = 50 \text{ Nm}$ for cartridge $M_{D,max} = 5 \text{ Nm}$ for coil retaining nut
Weight	$m = 0,96 \text{ kg}$
Volume flow	see symbols

**HYDRAULIC SPECIFICATIONS**

Fluid	Mineral oil, other fluid on request
Contamination efficiency	ISO 4406:1999, classe 18/16/13 (Required filtration grade $\beta_{6...10} \geq 75$ ) see data sheet 1.0-50/2
Viscosity range	12 mm <sup>2</sup> /s...320 mm <sup>2</sup> /s
Admissible fluid temperature *	-20...+40°C
Working pressure	$p_{max} = 350 \text{ bar}$
Nominal flow	$Q_N = 60 \text{ l/min}$
Max. volume flow	$Q_{max} = 80 \text{ l/min}$
Pressure drop	see characteristics
Opening pressure	1,4 bar

\* Deviating pressure medium - or ambient temperatures are possible for special arrangements after checking and authorisation by a responsible inspector. Measures for the prevention of the exceeding of the admissible solenoid surface - and internal temperatures can be: a good ventilation, low ambient temperatures (for higher pressure medium temperatures), limitation of the maximum possible power supply voltage, a short switching-on duration, installation on large heat dissipating blocks, etc. The responsibility in all cases lies with the operator, resp. with his inspector.

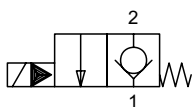
**SYMBOLS**

SVXPM22-DC...

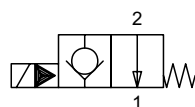

SVXPM22-CD...

**ELECTRICAL CONTROL**

Construction	Switching solenoid, wet pin pull- or push type, pressure tight.
Standard-nominal voltage	$U_N = 24$ VDC $U_N = 115$ VAC, $U_N = 230$ VAC DC = Ripple component 20%; wired with VDR AC = 50 to 60 Hz $\pm$ 2%; with integrated half wave rectifier and recovery diode
Voltage tolerance	$\pm 10\%$ of nominal voltage
Protection class	IP65/IP67 acc. to EN 60 529 (if correctly mounted)
Relative duty cycle	100% DF
Switching cycle	5000/h
Operating life	$10^7$ (number of switching cycles, theoretically)
Connection/Power supply	Through cable entry for cable diameter $\varnothing$ 6...12 mm
Execution T4:	II 2 G EEx em II T4 (for gas) II 2 D IP65 T130 °C (for dust)
Nominal power	17 W (DC), 23 VA (AC)

**START-UP**

1. In the power supply for each solenoid a fuse of an appropriate rating (max. 3 times  $I_b$  of solenoid, DIN 41571 or IEC 127) respectively a motor circuit breaker with electromagnetic and thermal interruption must be installed. The fuse may be located in the power supply unit for the solenoid or between power supply and solenoid. The voltage rating for the fuse must be equal or higher than the one for the solenoid.

2. The solenoid coils must only be operated on the valve belonging to them. More information concerning the installation and commissioning is contained in the operating instructions supplied together with the solenoid coil.

**CHARACTERISTICS** oil viscosity  $\nu = 30$  mm<sup>2</sup>/s

$p = f(Q)$  Performance limits at 10% under voltage and max. ambient temperature

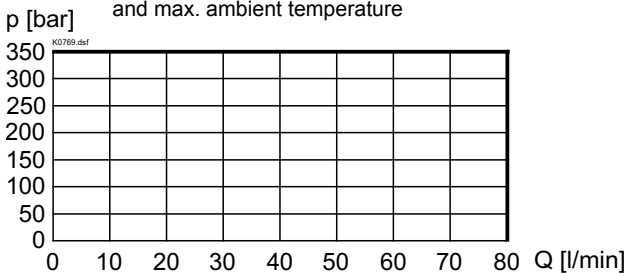
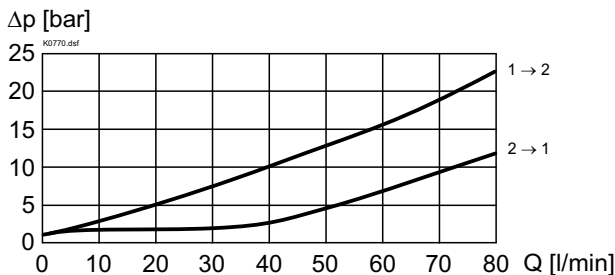
 $\Delta p = f(Q)$  Pressure volume flow characteristics

**DIMENSIONS / SECTIONAL DRAWING**

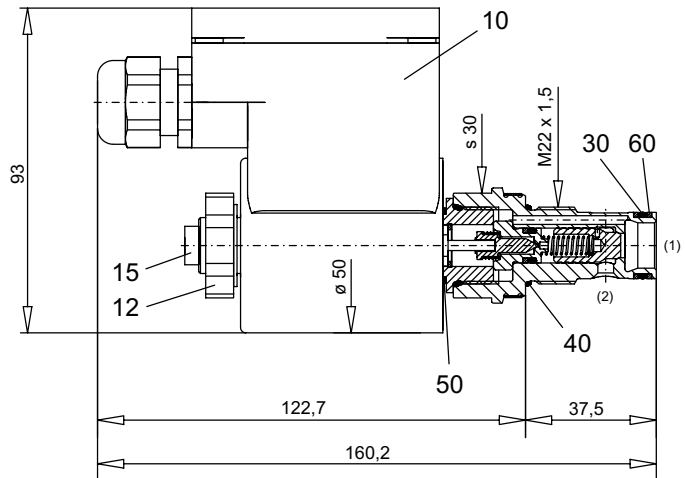
2/2-way version, «normally closed» [DC]

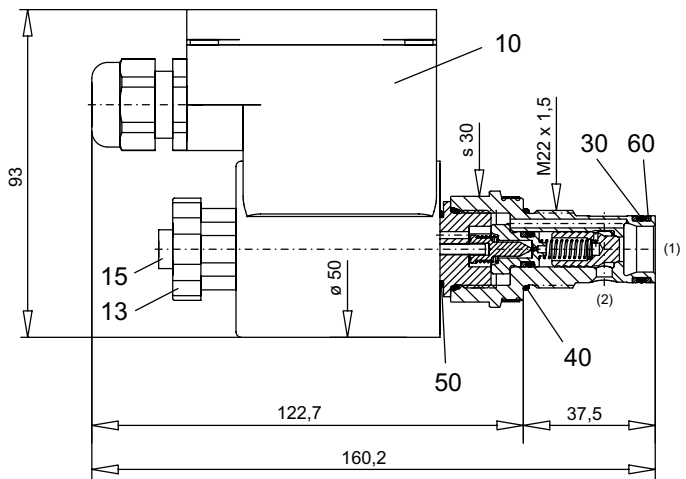

2/2-way version, «normally open» [CD]

**PARTS LIST**

Position	Article	Description
10	207.5...	Coil type EExem
12	154.2600	Knurled nut M16x1x9
13	154.2601	Knurled nut M16x1x18
15	239.2033	Plug HB0 (incl. seal)
30	160.2156	O-ring ID 15,60x1,78
40	160.2188	O-ring ID 18,77x1,78
50	160.6156	O-ring Viton ID 15,60x1,78
60	049.3196	Back-up ring RD 16,1x19x1,4

**ACCESSORIES**

Cartridge built-in in flange- or sandwich body

Flange valve

Sandwich valve

register 1.11

register 1.11

 Cavity drawing ISO 7789-22-01-0-98  
 and cavity tools see

data sheet 2.13-1008

Technical explanation see data sheet

1.0-100