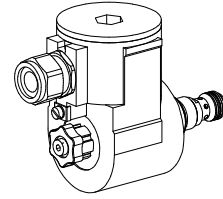

**Solenoid poppet valve cartridge
 2/2-way version**

- direct operated
- $Q_{max} = 40 \text{ l/min}$
- $p_{max} = 350 \text{ bar}$

M22x1,5
 ISO 7789

DESCRIPTION

Direct operated 2/2-way and 3/2-way solenoid poppet valve in screw-in cartridge design with thread M22 x1,5 for cavity acc. to ISO 7789. EEx: in accordance with European standards EN 50014, EN 50018
 d: flameproof enclosure
 Group II C: (gas group II A, II B) for all applications except mining
 Zone 1: (and 2): explosive mixture present intermittently
 EC-type examination certificate: PTB 98 ATEX 1009

FUNCTION

The pressure tight switching solenoid and in turn the spring on the opposite side shift the guided poppet into an either open or closed position. Due to the equal-area- and balanced-poppet-design there are no undesired opening or closing forces. Fluid may pass the poppet valve in both directions. The poppet piston is sealed by an o-ring. The seat with metallic seal closes leak free in both directions.

APPLICATION

Wandfluh solenoid operated poppet valves are applied where an absolutely leak free closing of the valve is essential like in load holding-, clamping- or gripping functions. These valves are suitable for hazardous areas in off-shore and shipbuilding applications as well as in the chemical-, oil- and gas industry. The screw-in cartridges are mainly used in mobile or station-ary integrated blocks and in size NG4-Mini and NG6 flange and sandwich bodies. To machine the cavities in steel or aluminium blocks, cavity tools may be supplied (hire or purchase). Please refer to the data sheets in register 2.13.

CONTENT

GENERAL SPECIFICATIONS.....	1
HYDRAULIC SPECIFICATIONS.....	1
SYMBOLS.....	2
ELECTRICAL CONTROL.....	2
START-UP.....	2
CHARACTERISTICS.....	2
DIMENSIONS/SECTIONAL DRAWING.....	3/4
PARTS LIST.....	4
ACCESSORIES.....	4

TYPE CODE

S D Y PM22 - <input type="checkbox"/> - <input type="checkbox"/> / T4 # <input type="checkbox"/>							
Poppet valve	<input type="checkbox"/>						
Direct operated	<input type="checkbox"/>						
Explosion proof solenoid EEx d	<input type="checkbox"/>						
Screw-in cartridge M22x1,5	<input type="checkbox"/>						
2/2-way, «normally closed»	<input type="checkbox"/> BA						
2/2-way, «normally open»	<input type="checkbox"/> AB						
3/2-way	<input type="checkbox"/> FG						
Standard-nominal voltage U_N :	<table border="0"> <tr> <td>24 VDC</td> <td><input type="checkbox"/> G24</td> </tr> <tr> <td>115 VAC</td> <td><input type="checkbox"/> R115</td> </tr> <tr> <td>230 VAC</td> <td><input type="checkbox"/> R230</td> </tr> </table>	24 VDC	<input type="checkbox"/> G24	115 VAC	<input type="checkbox"/> R115	230 VAC	<input type="checkbox"/> R230
24 VDC	<input type="checkbox"/> G24						
115 VAC	<input type="checkbox"/> R115						
230 VAC	<input type="checkbox"/> R230						
Execution T1...T4	<input type="checkbox"/>						
Design-Index (Subject to change)							

GENERAL SPECIFICATIONS

Description	Direkt operated 2/2-way and 3/2 way solenoid poppet valve
Construction	Screw-in cartridge for cavity acc. to ISO 7789
Operation	Solenoid
Mounting	Screw-in thread M22x1,5
Admissible ambient temperature *	-20...+40°C
Mounting position	any, preferably horizontal
Fastening torque	$M_D = 50 \text{ Nm}$ for cartridge $M_{D,max} = 5 \text{ Nm}$ for coil retaining nut
Masse	$m = 2,51 \text{ kg}$ 2/2-way $m = 2,53 \text{ kg}$ 3/2-way
Volume flow	any (note performance limits)

HYDRAULIC SPECIFICATIONS

Fluid	Mineral oil, other fluid on request
Contamination efficiency	ISO 4406:1999, class 18/16/13 (Required filtration grade $\beta_{6...10} \geq 75$) (see data sheet 1.0-50/2)
Viscosity range	12 mm ² /s...320 mm ² /s
Admissible fluid temperature *	-20...+40°C
Working pressure	$p_{max} = 350 \text{ bar}$
Nominal volume flow	$Q_N = 20 \text{ l/min}$
Max. volume flow	$Q_{max} = \text{up to } 40 \text{ l/min}$
Pressure drop	$\Delta p_{max} = < 7 \text{ bar}$ with 20 l/min

* Deviating pressure medium - or ambient temperatures are possible for special arrangements after checking and authorisation by a responsible inspector. Measures for the prevention of the exceeding of the admissible solenoid surface - and internal temperatures can be: a good ventilation, low ambient temperatures (for higher pressure medium temperatures), limitation of the maximum possible power supply voltage, a short switching-on duration, installation on large heat dissipating blocks, etc. The responsibility in all cases lies with the operator, resp. with his inspector.

SYMBOLS

SDYPM22 - BA...

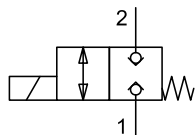

SDYPM22 - AB...

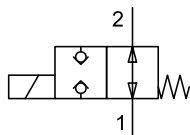

SDYPM22 - FG...

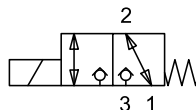

Transitional function - «FG»...

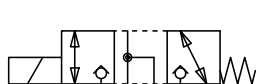
START-UP

Information for the installation and commissioning can be obtained from the operating instructions of the solenoid coil supplied with it.

ELECTRICAL CONTROL

Construction	Switching solenoid, wet pin push type, pressure tight.
Standard-nominal voltage	UN = 24 VDC UN = 115 VAC, UN = 230 VAC DC = wired with VDR AC = 50 to 60 Hz ± 2%; with integrated half wave rectifier and recovery diode
Voltage tolerance	±10 % of nominal voltage
Protection class	IP65 acc. to EN 60 529 (if correctly mounted)
Relative duty cycle	100 % DF
Switching cycle	5'000/h
Operating life	10 ⁷ (number of switching cycles,
Connection/Power supply	Through cable entry for cable diameter Ø 11...14 mm
Temperature classe	T1...T4 to EN 50 014
Nominal power	22 W (DC), 35 VA (AC)

CHARACTERISTICS oil viscosity $\nu = 30 \text{ mm}^2/\text{s}$

$p = f(Q)$ Performance limits at 10% under voltage and max. ambient temperature
2/2-way type, «normally closed» [BA]

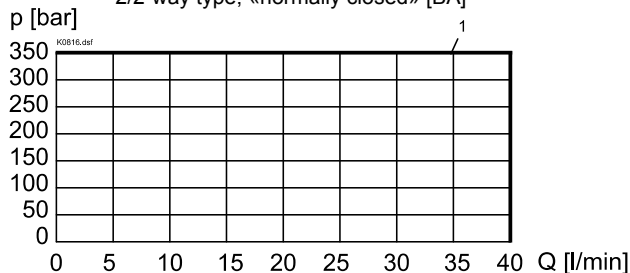

Version	Flow direction	
	1 → 2	2 → 1
SDYPM22-BA-...	1	1

$p = f(Q)$ Performance limits at 10% under voltage and max. ambient temperature
2/2-way type, «normally open» [AB]

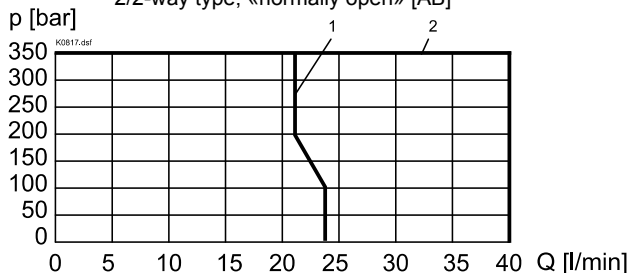

Version	Flow direction	
	1 → 2	2 → 1
SDYPM22-AB-...	1	2

$p = f(Q)$ Performance limits at 10% under voltage and max. ambient temperature
3/2-way type [FG]

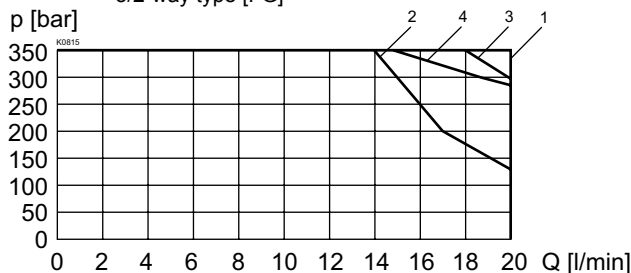

Version	Flow direction			
	1 → 2	2 → 1	2 → 3	3 → 2
SDYPM22-FG-...	2	1	4	3

$\Delta p = f(Q)$ Pressure volume flow characteristics

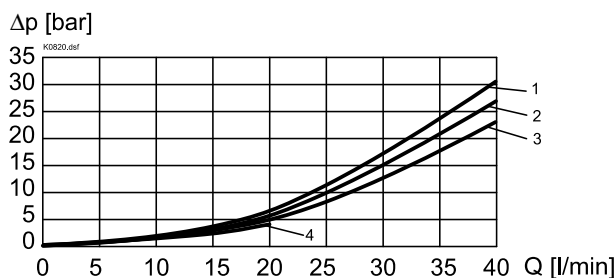

Version	Flow direction			
	1 → 2	2 → 1	2 → 3	3 → 2
SDYPM22-BA-...	1	2	-	-
SDYPM22-AB-...	3	4	-	-
SDYPM22-FG-...	-	4	1	1

REMARK!

 Depending on application the volume flow may be increased but during shifting the total volume flow (3 → 2 and 2 → 1) must not be higher than $Q = 30 \text{ l/min}$

DIMENSIONS/SECTIONAL DRAWING

2/2-way, «normally closed» [BA]

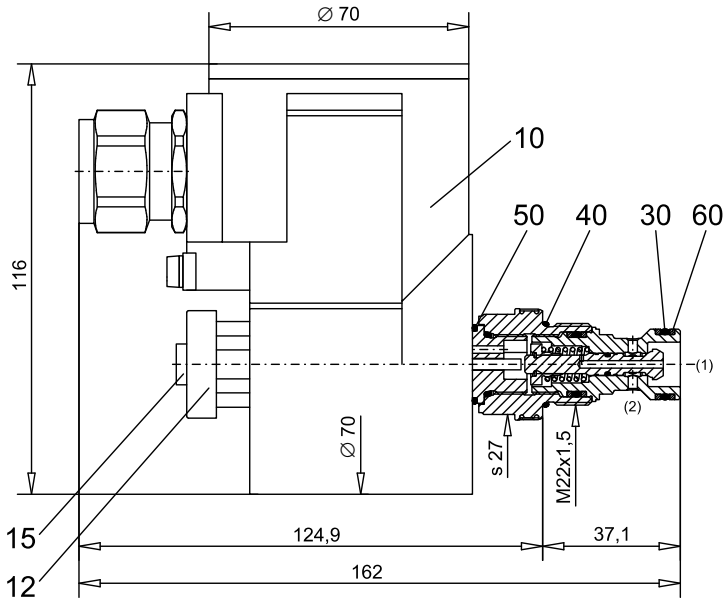

CAVITY

Cavity drawing for 2/2-way version to ISO 7789-22-01-0-98

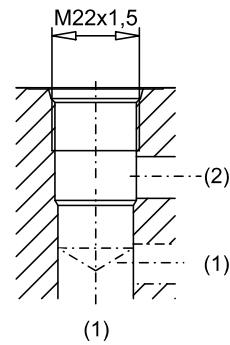

For detailed cavity drawing and cavity tools see data sheet 2.13-1008

2/2-way, «normally open» [AB]

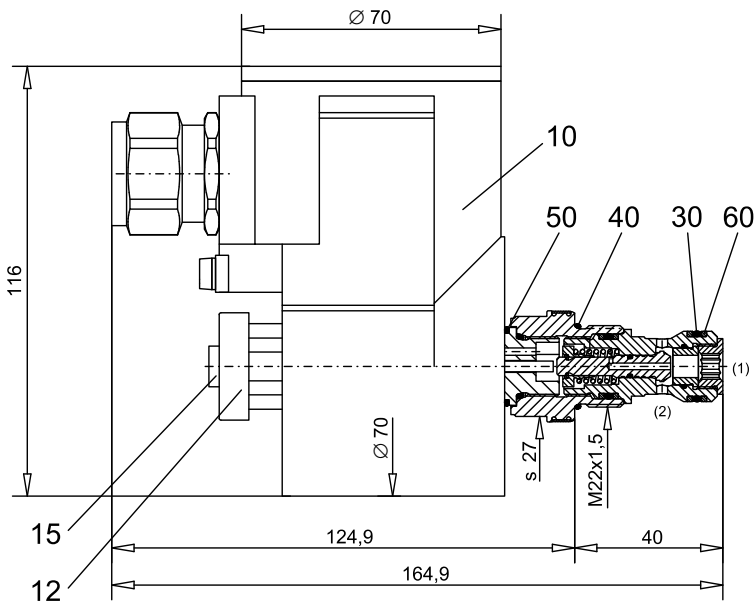

DIMENSIONS / SECTIONAL DRAWING

3/2-way version

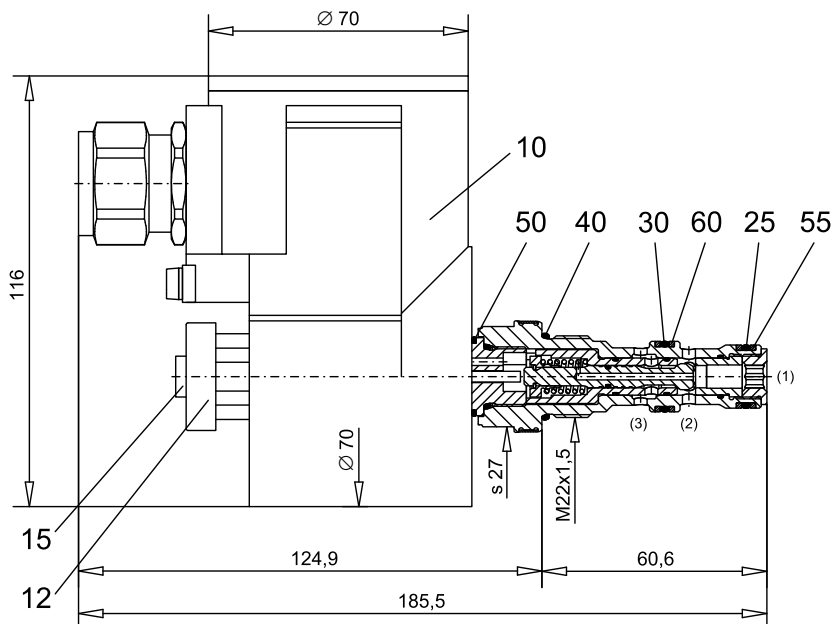
CAVITY

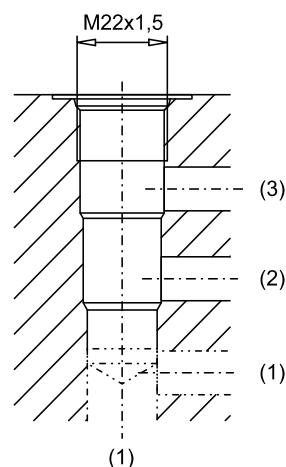
 Cavity drawing for 3/2-way version
 to ISO 7789-22-01-0-98

 For detailed cavity drawing and cavity tools
 see data sheet 2.13-1004

PARTS LIST

Position	Article	Description
10	207.5...	Coil type EExd
13	154.2601	Knurled nut M16x1x18
15	239.2033	Plug HB0 (inkl. Dichtung)
25	160.2140	O-ring ID 14,00x1,78
30	160.2156	O-ring ID 15,60x1,78
40	160.2188	O-ring ID 18,77x1,78
50	160.6156	O-ring Viton ID 15,60x1,78
55	049.3176	Back-up ring RD 14,1x17x1,4
60	049.3196	Back-up ring RD 16,1x19x1,4

ACCESSORIES

Cartridge built-in flange- or sandwich body:

Flange valve

register 1.11

Sandwich valve

register 1.11

Technical explanation see data sheet

1.0-100