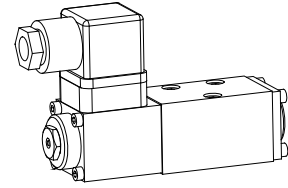

Proportional directional valve

- not pressure compensated
- $Q_{max} = 8 \text{ l/min}$
- $Q_N = 5 \text{ l/min}$
- $p_{max} = 315 \text{ bar}$

NG3-Mini[®]

DESCRIPTION

Direct operated proportional spool valve in flange design NG3-Mini according to Wandfluh standard with 4 ports. The spool valve is designed to the 5 chamber principle. The volume flow is adjusted by a Wandfluh proportional solenoid (VDE standard 0580). Low pressure drop due to the body design and spool profiling. The spool is made of hardened steel. The body made of high grade hydraulic casting for long service life is painted. The cover and the solenoid are zinc coated.

FUNCTION

Proportionally to the solenoid current spool stroke, spool opening and valve volume flow will increase. Proportional directional valves NG3-Mini are not load-compensated. The optimum spool shape and progressive characteristics curve allow fine motion control. To control the valve Wandfluh proportional amplifiers are available (see register 1.13).

APPLICATION

Proportional directional spool valves are well suited for demanding applications where high resolution, high volume flow and low hysteresis are requested. They are implemented in industrial hydraulics as well as in mobile hydraulics for the smooth control of hydraulic actuators. Mini-3 valves are used where both, reduced dimensions and weight are important. Application examples: pitch control of wind generators, forest and earth moving machines, machine tools and paper production machines with simple position controls, robotics and fan control.

CONTENT

| | |
|--|---|
| GENERAL SPECIFICATIONS..... | 1 |
| HYDRAULIC SPECIFICATIONS..... | 1 |
| ELECTRICAL SPECIFICATIONS..... | 1 |
| TYPE CHARTS/ DESIGNATIONS OF SYMBOLS..... | 2 |
| CONTROL MODE..... | 2 |
| CHARACTERISTICS..... | 2 |
| DIMENSIONS..... | 2 |
| PARTS LIST..... | 2 |
| ACCESSORIES..... | 2 |

TYPE CODE

| | |
|--|---|
| | WDP F A03 - <input type="checkbox"/> - <input type="checkbox"/> - 5 - <input type="checkbox"/> # <input type="checkbox"/> |
| Proportional directional valve | |
| Flange construction | |
| Interface nominal size 3-Mini | |
| Description of symbols acc. to table 1.10-65/2 | |
| Nominal flow at 10 bar pressure drop over 2 metering edges = 5 l/min | |
| Standard nominal voltage U_N : | 12 VDC <input type="checkbox"/> G12 24 VDC <input type="checkbox"/> G24 |
| Design-Index (Subject to change) | |

GENERAL SPECIFICATIONS

| | |
|----------------------------|--|
| Nominal size | NG3-Mini acc. to Wandfluh standard |
| Designation | 4/2-, 4/3-way prop. directional valve |
| Construction | Direct operated spool valve |
| Mounting | Flange, 3 fastening holes for socket head cap screws M4x30 |
| Fastening torque | 2,8 Nm (qual. 8.8) |
| Pipe connection | Connection plates Multi-station flange subplate Longitudinal stacking system |
| Mounting position | any, preferably horizontal |
| Ambient temperature | -20...+50°C |
| Weight: 1 solenoid-version | m = 0,5 kg |
| 2 solenoid-version | m = 0,6 kg |



HYDRAULIC SPECIFICATIONS

| | |
|--------------------------|--|
| Fluid | Mineral oil, other fluid on request |
| Contamination efficiency | ISO 4406:1999, class 18/16/13 (Required filtration grade $\beta_{6...10} \geq 75$) refer to data sheet 1.0-50/2 |
| Viscosity range | 12 mm ² /s...320 mm ² /s |
| Fluid temperature | -20...+70°C |
| Working pressure | $p_{max} = 315 \text{ bar}$ (connection P, A, B) |
| Tank pressure | $p_{max} = 160 \text{ bar}$ (connection T) |
| Nominal volume flow | $Q_N = 5 \text{ l/min}$ at 10 bar pressure drop over 2 metering edges |
| Max. volume flow | $Q_{max} = 8 \text{ l/min}$ |
| Leakage volume flow | see characteristic |
| Hysteresis | $\leq 5\% *$ * by optimal dithersignal |

ELECTRICAL SPECIFICATIONS

| | | |
|---------------------------------|---|------------------------|
| Construction | Proportional solenoid, wet pin push type, pressure tight | |
| Standard-Nominal voltage | U = 12 VDC | U = 24 VDC |
| Limiting current | $I_G = 1080 \text{ mA}$ | $I_G = 540 \text{ mA}$ |
| Relative duty factor | 100% DF (see data sheet 1.1-430) | |
| Protection class | IP 65 acc. to EN 60 529 | |
| Connection/Power supply | Over device plug connection acc. to ISO 4400/DIN 43650 (2P+E) | |
| Other electrical specifications | see data sheet 1.1-90 (PI29V) | |

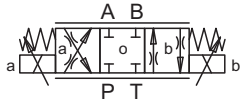
TYPE CHARTS / DESIGNATIONS OF SYMBOLS

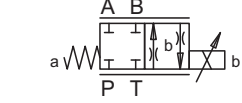
| | |
|---|--|
|  | ACB - S S = Symmetrical control mode |
|  | AC1 - S S = Symmetrical control mode |
|  | CB2 - S S = Symmetrical control mode |

| | |
|--|---|
|  | ADB - V V = Meter-in control mode |
|--|---|

CHARACTERISTICS oil viscosity $\nu = 30 \text{ mm}^2/\text{s}$
 $Q = f(I)$ Volume flow-signal-characteristics

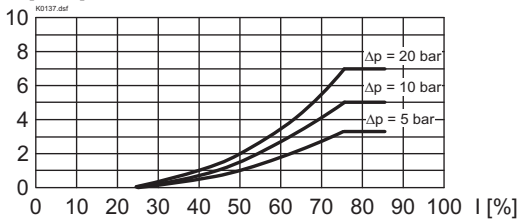
 Q [l/min]

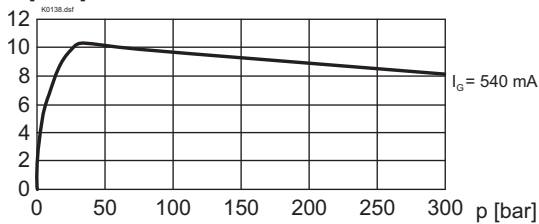
 $Q = f(p)$ Volume flow-pressure-characteristics

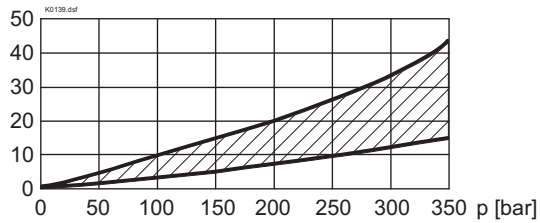
 Q [l/min]

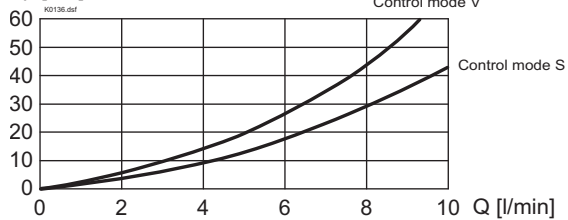
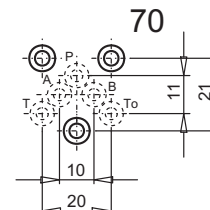
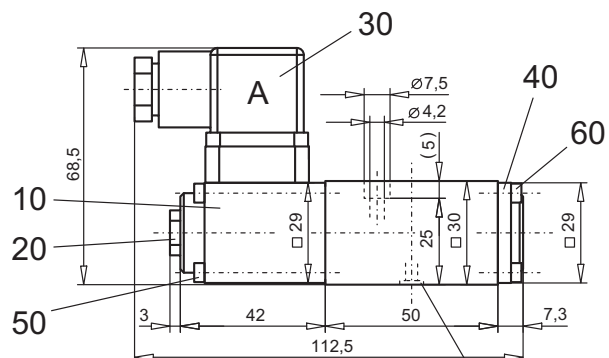
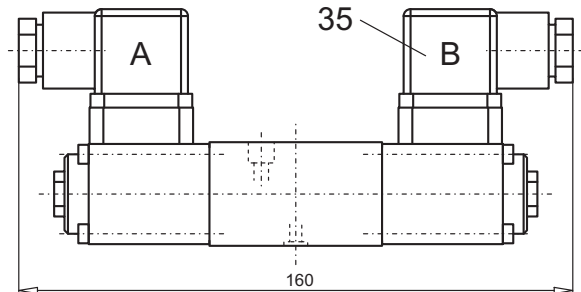
 $Q_L = f(p)$ Leakage-characteristics

 Q [cm³/min]

 $\Delta p = f(Q)$ Pressure loss/flow-characteristics over 2 metering edges

 Δp [bar]

DIMENSIONS

PARTS LIST

| Position | Article | Description |
|----------|----------------------|--|
| 10 | 256.2453 256.2418 | Proportional solenoid PI29V-G24 Proportional solenoid PI29V-G12 |
| 20 | 253.8000 | Plug with integrated manual override HB4,5 |
| 30 | 219.2001 | Plug A (grey) |
| 35 | 219.2002 | Plug B (black) |
| 40 | 056.4100 | Cover |
| 50 | 246.0141 | Socket head cap screw M3x40 DIN 912 |
| 60 | 246.0109 | Socket head cap screw M3x8 DIN 912 |
| 70 | 160.2045 | O-ring ID 4,50x1,5 |

ACCESSORIES

 Sub-plates
 Proportional-amplifier

 Register 2.9
 Register 1.13

Technical explanation see data sheet 1.0-100E